

RATHDOWNE

STAGE 12 - STREETSCAPE

PROJECT NUMBER: 308530
 LANDSCAPE ARCHITECTURE DRAWINGS
 FOR VILLAWOOD

DRAWING SCHEDULE			
DRAWING NO.	DESCRIPTION	SHEET NO.	REVISION
LD100	COVER - SHEET 1	1	B
LD700	PLANTING PLANS - SHEET 1	2	B
LD701	PLANTING PLANS - SHEET 2	3	B
LD900	DETAILS - SHEET 1	4	B

PLANNING AND ENVIRONMENT ACT
 CITY OF WHITTLESEA
 PLANNING SCHEME
 Plan referred to in Permit to use and/or develop land.
 Application No: 716630
 Condition No: 18.2
 Sheet 1 of 4
 Date Permit issued: 04/08/2017
 Date: 1/12/2021
 Town Planner

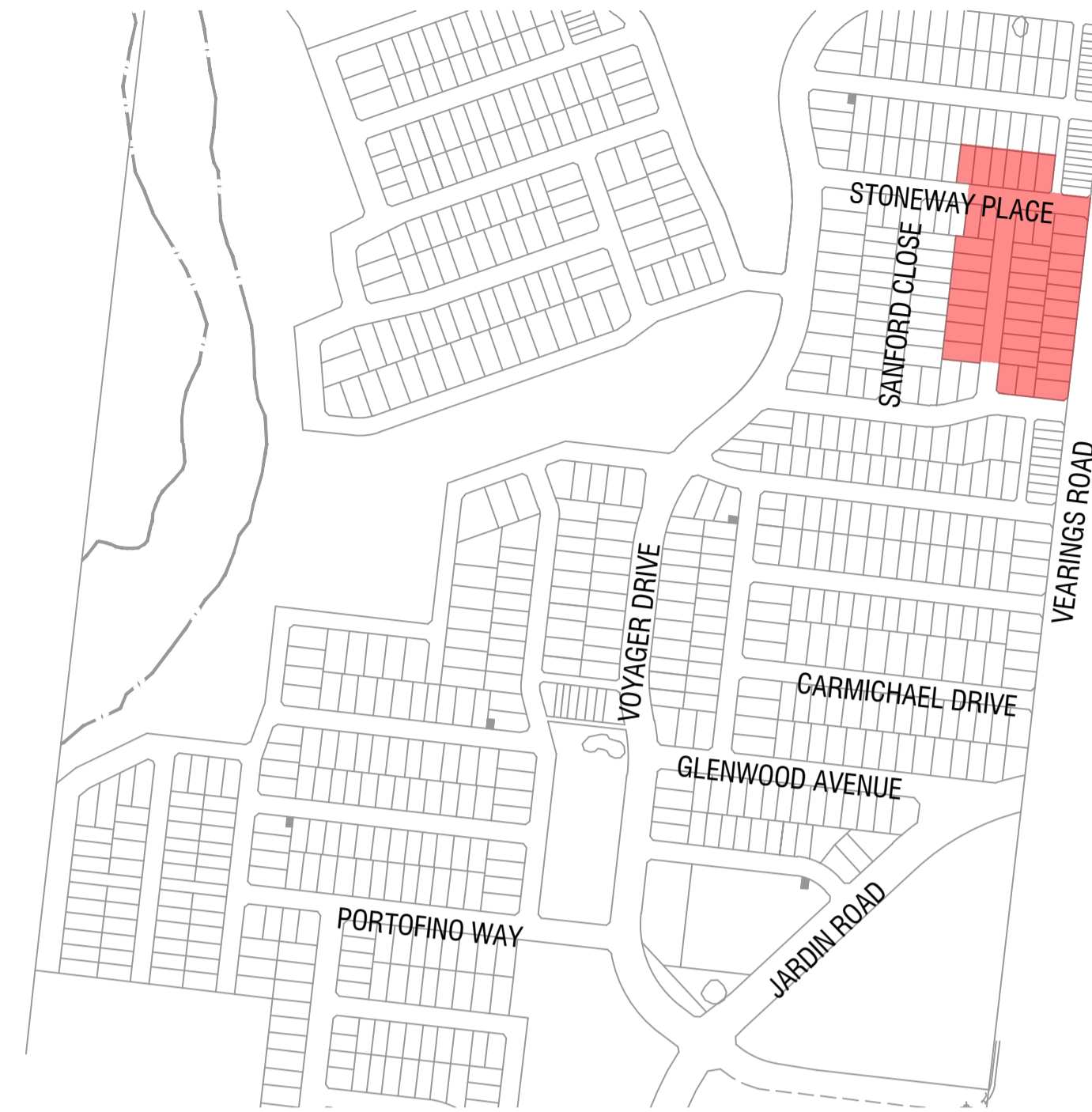

2 KEY PLAN
 Scale 1:5000 @ A1



1 RATHDOWNE STAGE 12
 Scale 1:1000 @ A1

PLANTING SCHEDULE						
TREES						
CODE	BOTANICAL NAME	COMMON NAME	QTY	DENSITY	INSTALL SIZE	MATURE SIZE (h x w)
Ba	<i>Brachytilon acerifolius</i>	Flame Tree	13	as shown	min. 1.5m tall, 45L	10 x 6
Cs	<i>Corymbia citriodora</i> 'Scentuous'	Dwarf Lemon Scented Gum	6	as shown	min. 1.5m tall, 45L	7 x 5
Lc	<i>Lophostemon confertus</i>	Queensland Brush Box	20	as shown	min. 1.5m tall, 45L	15 x 10
Total			39			

ALL TREE STOCK TO CONFORM TO AS 2303:2018; APPENDIX D.
 ALL TREE STOCK OF 45L TO HAVE A HEIGHT OF 1.5m - 2.0m AND CALIPER OF 25mm - 30mm
 UNLESS APPROVED IN WRITING BY THE SUPERINTENDENT

GENERAL NOTES

- Unless otherwise specified on the drawings all measurements, lengths, heights and distances to be determined from dimensions and NOT scaled off the drawings.
- Before commencement of any works it is the responsibility of the Landscape Contractor to contact Dial Before You Dig 1100 (Fax 1300 652 077) for information on services in the area shown on the plan (www.dialbeforeyoudig.com.au)
- The locations of underground services are approximate only and their exact position should be proven on site. No guarantee is given that all existing services are shown. The Contractor shall verify the location and depth of all services prior to commencing on site.
- The Contractor must have a copy of Melbourne One Call/Services information and plans on site at all times.
- The Contractor shall be liable for any damage to services during landscape works.
- All trees shall be planted in locations shown on this plan, with setout to be approved on site by the Superintendent prior to planting.
- Tree canopies are shown at 75% of mature diameter.
- Any change in plant species must have the approval of the Superintendent.
- Trees shall not be planted less than the following distances from existing elements, unless otherwise stated in the documentation:
 - Pedestrian pathways - 1.2m
 - Pedestrian pathways in reserve - 2.0m
 - Driveways and crossovers - 3.0m
 - Stormwater and sewerage pits - 2.0m
 - Intersections - 10.0m
 - Service crossings - 2.0m
 - Back of Kerb - 1.0m min.
 - Street lights and power poles - 4.0m
 - Service assets, incl. junction boxes, pits etc - 2.0m
 - Fire plugs - 3.0m
- The Superintendent is to inspect trees supplied by the Contractor prior to planting.
- The Principal will ensure that all property boundaries are to be pegged out by licensed surveyors prior to set out of landscape works.
- All drawings 'For Construction' to be printed in colour

spiire

© Spiire Australia Pty Ltd All Rights Reserved
 This document is produced by Spiire Australia Pty Ltd solely for the benefit of and use by the client in accordance with the terms of the retainer. Spiire Australia Pty Ltd does not and shall not assume any responsibility or liability whatsoever to any third party arising out of any use or reliance by third party on the content of this document.

L6 414 LA TROBE STREET PO BOX 16084 MELBOURNE
 VICTORIA 8007 AUSTRALIA T 61 3 9993 7888
 www.spiire.com.au ABN 55 050 029 635

PRELIMINARY

B	ISSUED TO COUNCIL	ML	04/11/21
A	ISSUED TO COUNCIL	MB	05/10/21
REV	DESCRIPTION	APP	DATE

RATHDOWNE
 STAGE 12 - STREETSCAPE

DETAILED DESIGN

COVER - SHEET 1

SHEET 1 OF 4

CITY OF WHITTLESEA



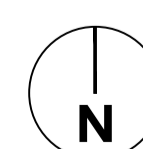

VILLAWOOD

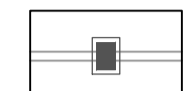
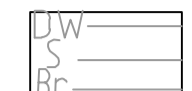
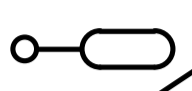
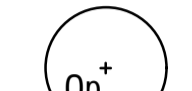

MGA 94 ZONE 1:5000 SCALE @ A1 0 50 100 150 200 250

DESIGNED	DRAWN	CHECKED	APPROVED
AS	AS	ML	MB
DATE	DRG NO.	REV	
05/10/2021	308530LD100	B	

LEGEND

-  EXTENT OF WORKS
-  EXISTING STORMWATER
By others / refer Civil
-  EXISTING CONDUITS / SERVICES
By others / refer Civil
-  EXISTING STREET LIGHTS
Refer Power
-  STREET TREE
Refer Schedules, Details and Specification
-  HYDROSEED GRASS
Refer Details and Specification
-  2.5M ELECTRICAL JOINT AND
CONDUIT END OFFSET
-  3M LIGHT POLE AND
PARALLELING PILLAR OFFSET

PLANNING AND ENVIRONMENT ACT
CITY OF WHITTLESEA
PLANNING SCHEME
Plan referred to in Permit to use and/or develop land.
Application No: 716630
Condition No: 18.2
Sheet 2 of 4
Date Permit issued: 04/08/2017

 Date: 1/12/2021
Town Planner

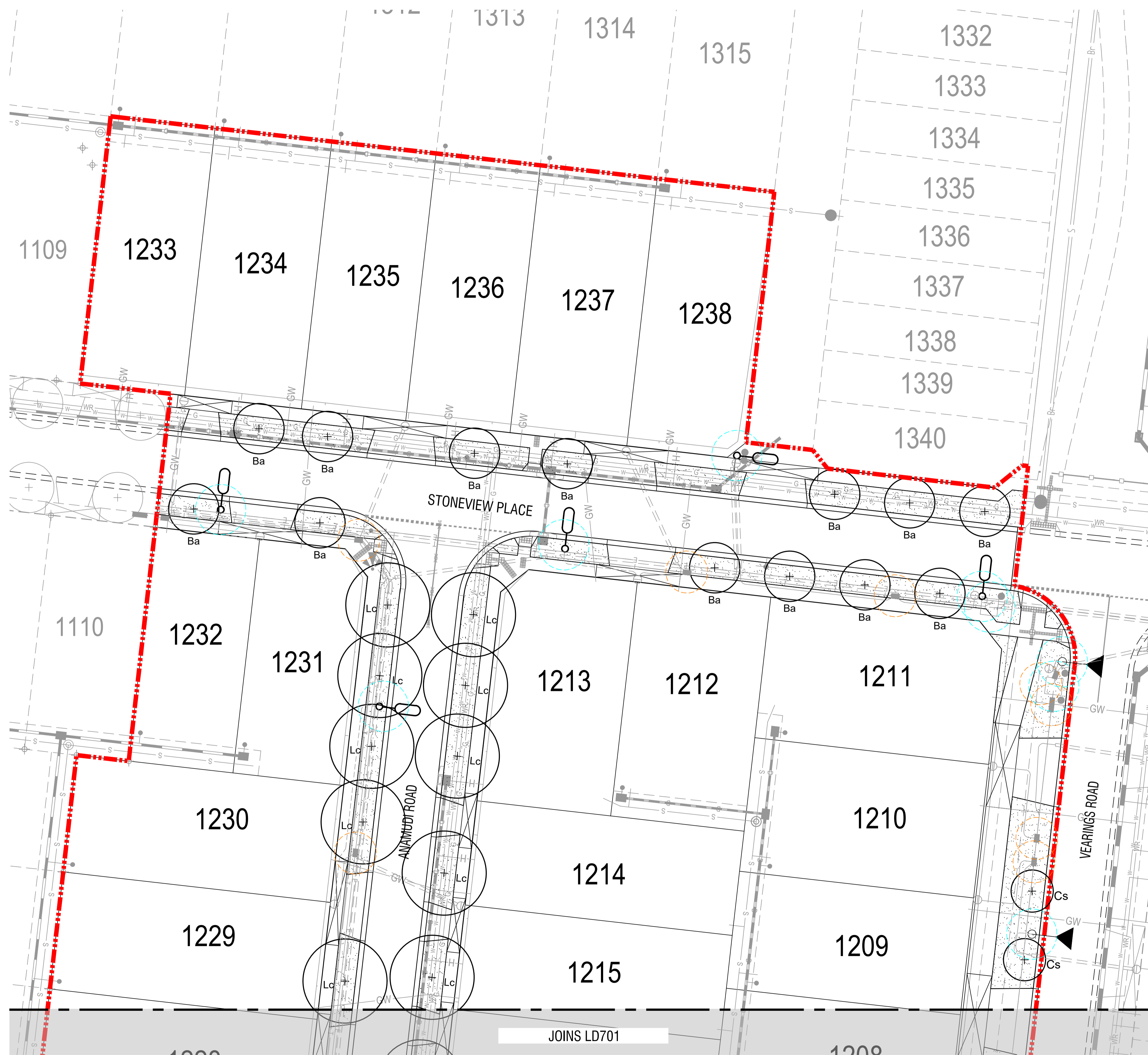

NOTES

spiire

© Spiire Australia Pty Ltd All Rights Reserved
This document is produced by Spiire Australia Pty Ltd solely for the benefit of and use by the client in accordance with the terms of the retainer. Spiire Australia Pty Ltd does not and shall not assume any responsibility or liability whatsoever to any third party arising out of any use or reliance by third party on the content of this document.

L6 414 LA TROBE STREET PO BOX 16084 MELBOURNE
VICTORIA 8007 AUSTRALIA T 61 3 9993 7888
www.spiire.com.au ABN 55 050 029 635

PRELIMINARY



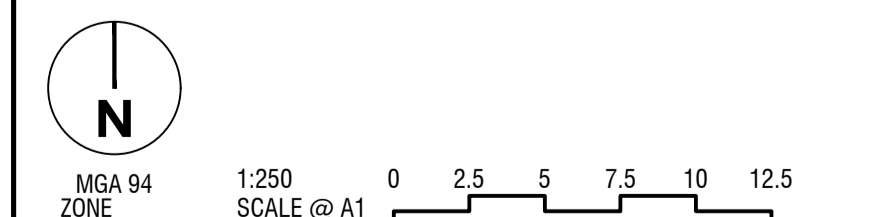

B	ISSUED TO COUNCIL	ML	04/11/21
A	ISSUED TO COUNCIL	MB	05/10/21
REV	DESCRIPTION	APP	DATE

RATHDOWNE
STAGE 12 - STREETScape
DETAILED DESIGN
PLANTING PLANS - SHEET 1
SHEET 2 OF 4
CITY OF WHITTLESEA
VILLAWOOD

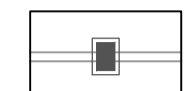
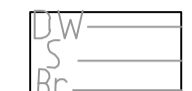
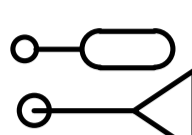
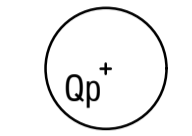

DESIGNED	DRAWN	CHECKED	APPROVED
AS	AS	ML	MB
DATE	DRG NO.	REV	
05/10/2021	308530LD700	B	

LEGEND

-  EXTENT OF WORKS
-  EXISTING STORMWATER
By others / refer Civil
-  EXISTING CONDUITS / SERVICES
By others / refer Civil
-  EXISTING STREET LIGHTS
Refer Power
-  STREET TREE
Refer Schedules, Details and Specification
-  HYDROSEED GRASS
Refer Details and Specification
-  2.5M ELECTRICAL JOINT AND
CONDUIT END OFFSET
-  3M LIGHT POLE AND
PARALLELING PILLAR OFFSET

PLANNING AND ENVIRONMENT ACT
CITY OF WHITTLESEA
PLANNING SCHEME
 Plan referred to in Permit to use and/or develop land.
 Application No: 716630
 Condition No: 18.2
 Sheet 3 of 4
 Date Permit issued: 04/08/2017
 Date: 1/12/2021
 Town Planner

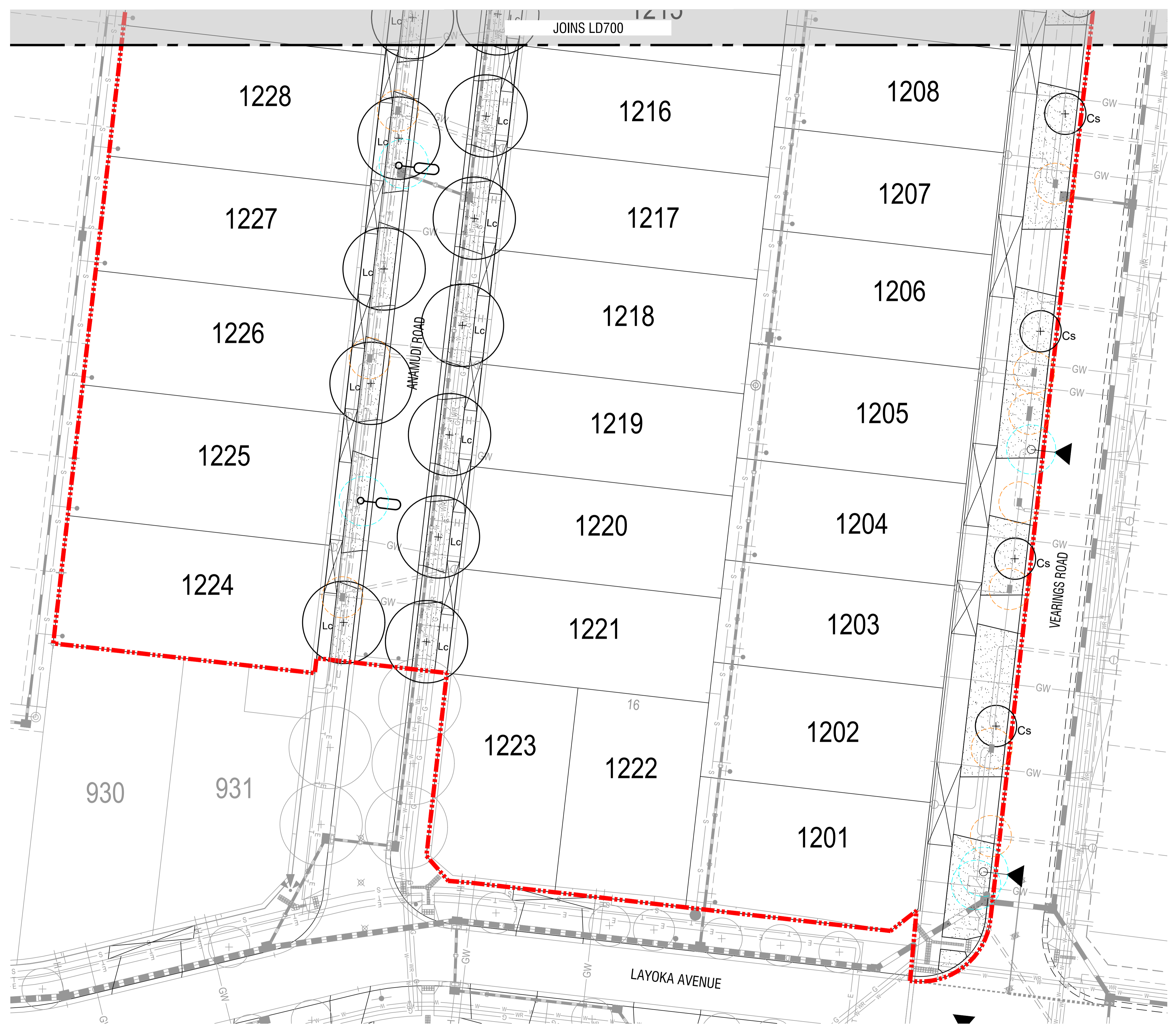

NOTES



© Spiire Australia Pty Ltd All Rights Reserved
 This document is produced by Spiire Australia Pty Ltd solely for the benefit of and use by the client in accordance with the terms of the retainer. Spiire Australia Pty Ltd does not and shall not assume any responsibility or liability whatsoever to any third party arising out of any use or reliance by third party on the content of this document.
L6 414 LA TROBE STREET PO BOX 16084 MELBOURNE
VICTORIA 8007 AUSTRALIA T 61 3 9993 7888
 www.spiire.com.au ABN 55 050 029 635

PRELIMINARY

B	ISSUED TO COUNCIL	ML	04/11/21
A	ISSUED TO COUNCIL	MB	05/10/21
REV	DESCRIPTION	APP	DATE

RATHDOWNNE

STAGE 12 - STREETScape

DETAILED DESIGN

PLANTING PLANS - SHEET 2
SHEET 3 OF 4
CITY OF WHITTLESEA
VILLAWOOD

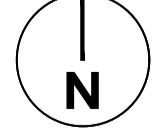
 MGA 94
 ZONE

1:250
 SCALE @ A1

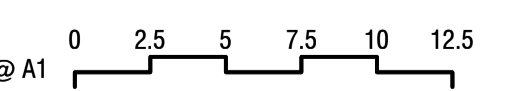

DESIGNED	DRAWN	CHECKED	APPROVED
AS	AS	ML	MB
DATE	DRG NO.	REV	
05/10/2021	308530LD701	B	

file name: 308530LD701.dwg, layout name: LD701, plotted by: Spencer Scullions
 file location: C:\Users\michael.d\OneDrive\Documents\308530\lanescapes\ACAD\plot area 04/11/2021 10:43 AM Sheet 3 of 4 Sheets

PLANNING AND ENVIRONMENT ACT
 CITY OF WHITTLESEA
 PLANNING SCHEME
 Plan referred to in Permit to use and/or develop land.
 Application No: 716630
 Condition No: 18.2
 Sheet 4 of 4
 Date Permit issued: 04/08/2017
 Date: 1/12/2021
 Town Planner

Tree watering (1): immediately after planting, tree shall be watered thoroughly regardless of weather conditions, quantity of water will be adequate to saturate the root ball to its core

Tree watering (2): post planting, provide a minimum of 15 litres of water (for tree in 45 litre pot) to the newly planted tree per 7 days. Water at a slow rate so as not to displace mulch. For trees in pot size larger than 45 litres, provide quantity of water one third of that pot size.

All trees to be healthy specimens free of pests and diseases. Trees to be well watered a maximum of 24hours prior to planting.

3 no. 50x50x2400mm hardwood stakes set vertically and clear of rootball and minimum 800mm into ground. Paint all exposed surfaces of stakes with matte black paint. Stakes are to be offset from the nearest underground service a minimum of 200mm to ensure no damage is caused to underground service

3 no. 50mm wide hessian ties loosely wrapped around trunk at 1/3 tree height and shade cloth fasteners to stakes allowing some trunk movement; refer to plan detail above.

Create dish to keep mulch clear of tree trunk. Top of root ball flush with finished level of planting hole.

75mm high berm to form a watering basin

200mm depth of approved aged wood mulch. Mulch shall be spread a minimum of 1200mm diameter from centre of tree and beyond of the planting hole overlapping undisturbed soil

Excavate a shallow planting hole with sloping sides 3 times the width of the root ball and break-up sides and base, refirm base. Depth of planting hole no deeper than the height of the root ball. Backfill with 50/50 blend imported topsoil/site topsoil broken up to friable texture, firming progressively.

Slow release fertiliser (for exotic species only)

Water retaining products to be mixed into backfilled soil as per manufacturers specifications.

Existing subgrade

Compact soil under rootball to prevent settling

NOTE: it is the responsibility of the contractor to confirm the location of all underground services prior to commencement of any excavation works, tree planting, specifications, street tree offsets / clearance, hold points, species substitution, tree staking and tree maintenance to be undertaken in accordance with City of Whittlesea minimum landscape maintenance specification of services and works May 2010.

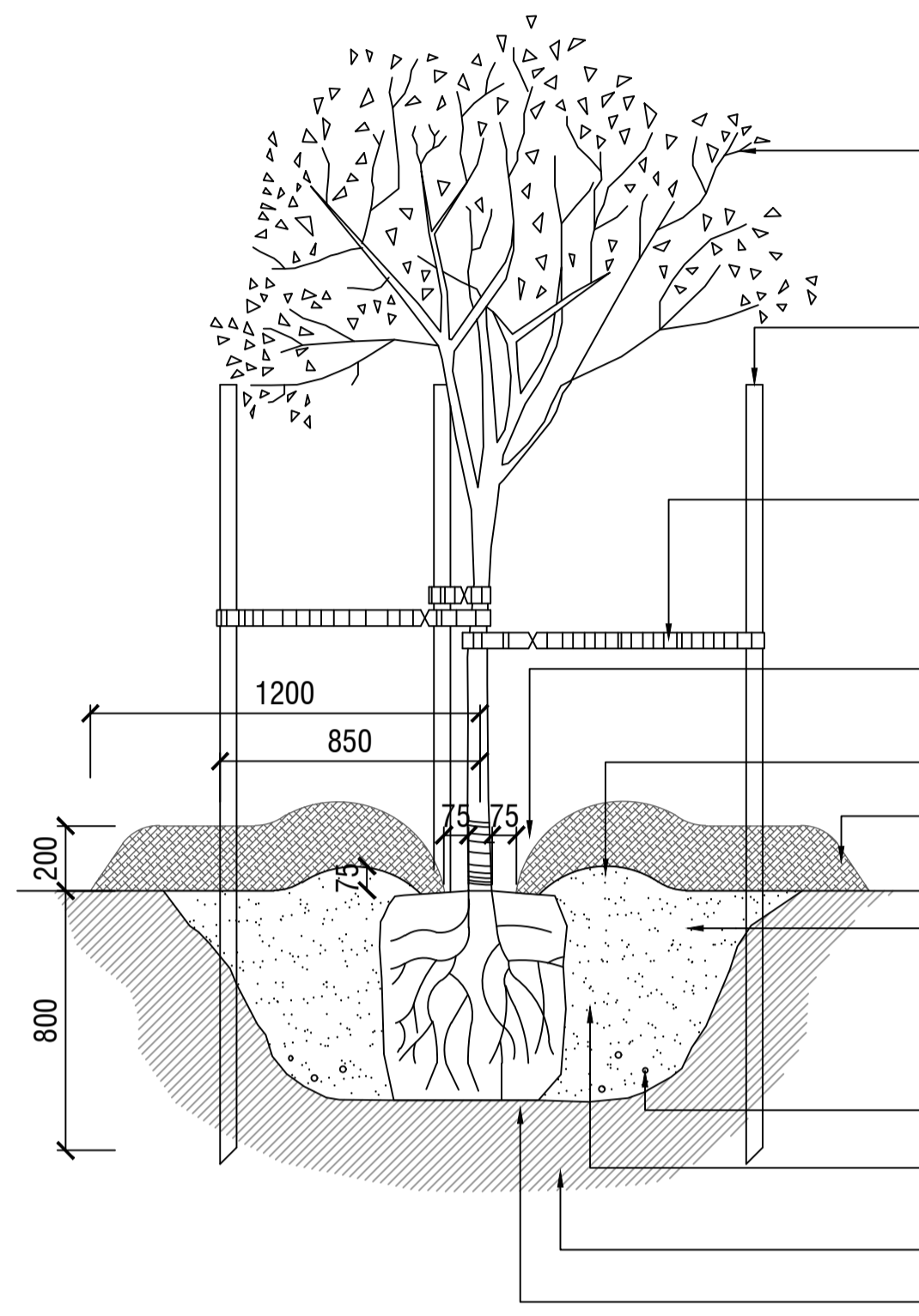

1 SEMI-ADVANCED TREE PLANTING DETAIL

Scale 1:20 @ A1

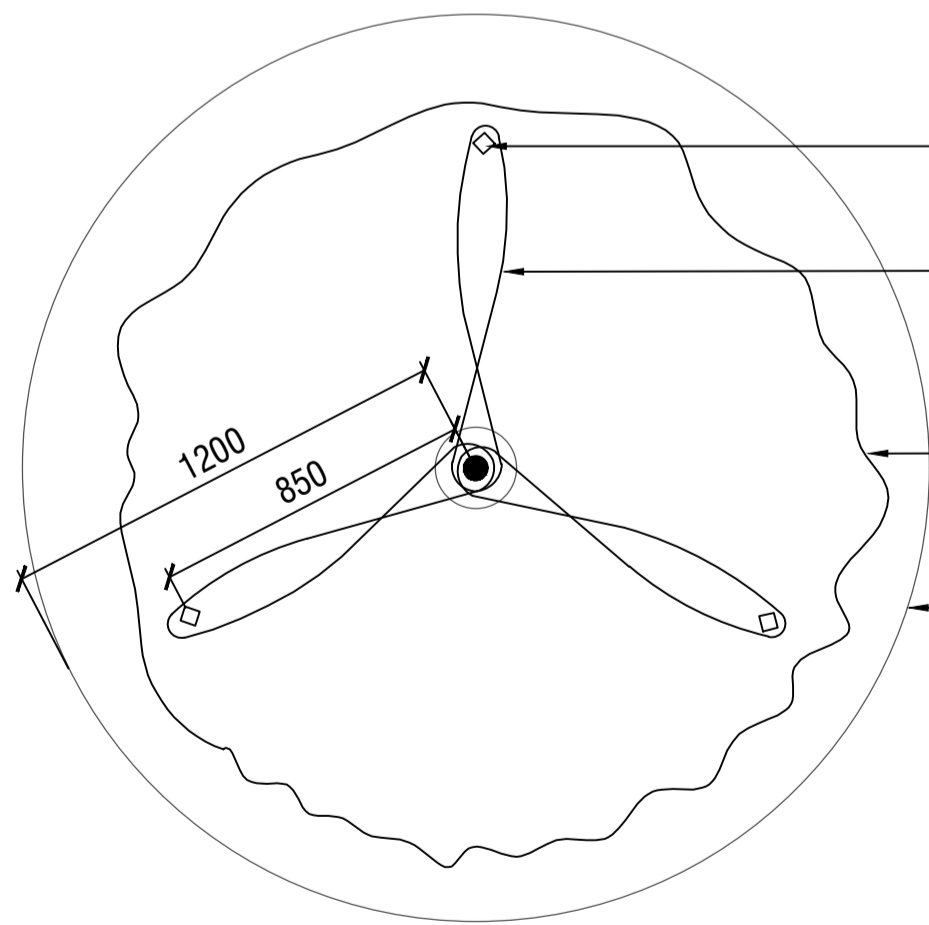

2 TREE TIE DETAIL

Scale 1:20 @ A1

NOTES

- Existing pasture grass and/or weeds are to be sprayed with herbicide.
- No machinery to be used within the drip line of existing trees.
- Topsoil to be raked to a fine tilth, removal of all surface rocks, large lumps of clay, weeds and rubbish prior to application of seed to all areas as shown.
- New grassed areas to be protected from trespass and traffic with star pickets and barrier rope until grass is established.

SEED MIX :
 15% Kikuyu
 70% Tall Fescue
 15% Perennial Rye

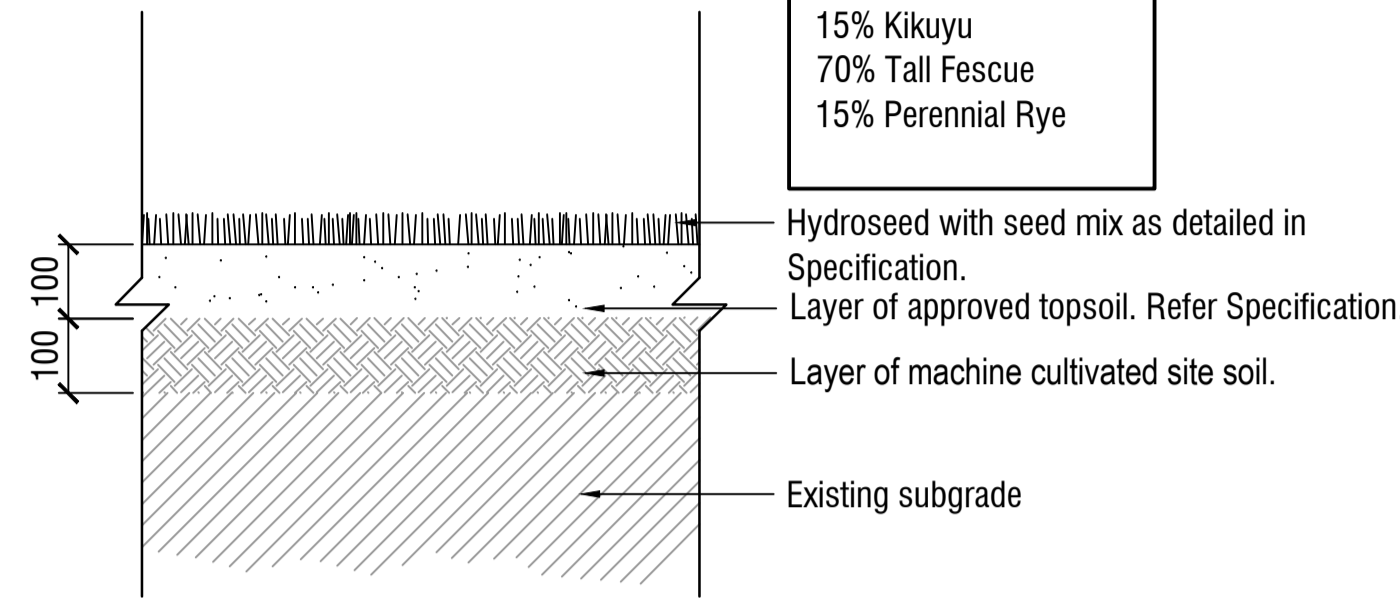

3 HYDROSEED GRASS DETAIL

Scale 1:10 @ A1

NOTES

spiire

© Spiire Australia Pty Ltd All Rights Reserved
 This document is produced by Spiire Australia Pty Ltd solely for the benefit of and use by the client in accordance with the terms of the retainer. Spiire Australia Pty Ltd does not and shall not assume any responsibility or liability whatsoever to any third party arising out of any use or reliance by third party on the content of this document.

L6 414 LA TROBE STREET PO BOX 16084 MELBOURNE
 VICTORIA 8007 AUSTRALIA T 61 3 9993 7888
 www.spiire.com.au ABN 55 050 029 635

PRELIMINARY

B	ISSUED TO COUNCIL	ML	04/11/21
A	ISSUED TO COUNCIL	MB	05/10/21
REV	DESCRIPTION	APP	DATE

RATHDOWNNE
 STAGE 12 - STREETScape

DETAILED DESIGN

DETAILS - SHEET 1

SHEET 4 OF 4

CITY OF WHITTLESEA

VILLAWOOD



AS SHOWN

DESIGNED	DRAWN	CHECKED	APPROVED
AS	AS	ML	MB
DATE	DRG NO.	REV	
05/10/2021	308530LD900	B	