

**SHEET INDEX**

SHT No.	VER	Description
1	P3	LAYOUT PLAN
2	P3	TYPICAL CROSS SECTIONS
3	P3	ROAD PAVEMENT DETAILS & NOTES
4	P3	INTERSECTION DETAIL PLANS
5	P3	LONGITUDINAL & CROSS SECTIONS SLAVKO DRIVE SHEET 1 OF 2
6	P3	LONGITUDINAL & CROSS SECTIONS SLAVKO DRIVE SHEET 2 OF 2
7	P3	LONGITUDINAL & CROSS SECTIONS FRANCA AVENUE
8	P3	DRAINAGE LONGITUDINAL SECTIONS - SHEET 1
9	P3	DRAINAGE LONGITUDINAL SECTIONS - SHEET 2
10	P3	DRAINAGE LONGITUDINAL SECTIONS - SHEET 3
11	P3	DRAINAGE PIT DETAILS
12	P3	SIGNAGE & LINEMARKING PLAN
13	P3	PASSIVE IRRIGATION PLAN
14	P3	MOBILITY PLAN
15	P3	EARTHWORKS PLAN

**NOTE:**  
KERB CUTOFF FOR PASSIVE IRRIGATION REFER TO DETAIL ON SHEET 12. FINAL STREET PIT LOCATION TO BE COORDINATED WITH LANDSCAPE DRAWINGS.

**WARNING**  
**BEWARE OF UNDERGROUND SERVICES**  
THE LOCATION OF UNDERGROUND SERVICES ARE APPROXIMATE ONLY AND THEIR EXACT POSITION SHOULD BE PROVEN ON SITE. NO GUARANTEE IS GIVEN THAT ALL EXISTING SERVICES ARE SHOWN.

PRELIMINARY LEVELS TO BE ADJUSTED DURING THE DETAILED DESIGN PHASE ONCE MW DRAINAGE SCHEME AND OVERLAND FLOWS HAVE BEEN APPROVED.

- ATTENTION TO CONTRACTOR**
- IT IS THE CONTRACTORS RESPONSIBILITY TO ENSURE THAT THE DIGITAL PLAN, PROVIDED FOR SETOUT PURPOSES, MATCHES THE TBM CO-ORDINATES SHOWN.
  - WHERE CONCRETE WORKS ABOUT A SEWER ACCESS CHAMBER SURROUND OR SIMILAR STRUCTURE, AN EXPANSION JOINT OF APPROVAL MATERIAL SHALL BE PROVIDED BETWEEN THE TWO FACES.

**SERVICE OFFSETS AND LOCATION TABLE**

Location	Gas	Water		Communications		Electricity		BOK	Road Width	Joint Trenching	Street Classification
		NDW	DW	Cables	Pits	Cables	Poles				
SLAVKO DRIVE (Lots 2701-2723)	2.10 N		2.60 N	1.80 S	1.70 S	2.30 S	1.00 BOK	4.20 N 4.20 S	16.00	G&W, FTH&E	ACCESS PLACE
SLAVKO DRIVE (Lots 2724-2729)	2.70 W		3.10 W	1.80 W	1.80 W	2.15 W	1.20 BOK	4.35 W 3.35 E	15.30	G&W, FTH&E	ACCESS PLACE
FRANCA AVENUE	2.10 W		2.60 W	1.80 E	1.70 E	2.30 E	1.00 BOK	4.20 W 4.20 E	16.00	G&W, FTH&E	ACCESS PLACE

NOTE: \* OFFSET FROM BACK OF KERB

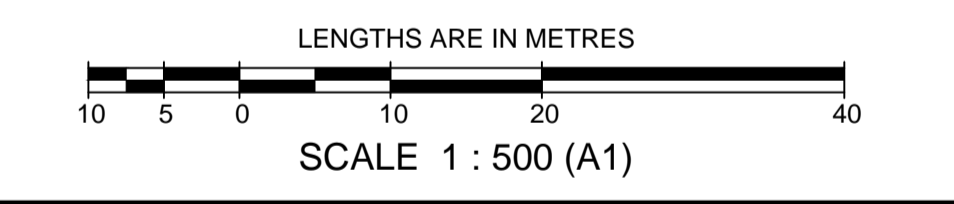

**APPROVED DETAILED ENGINEERING PLANS**  
Nihal Jayasekera  
ENGINEERING SERVICES  
Date: 26/11/2021

**SYMBOL LEGEND**

Prop	Prev Stage	Ex/Natural/FS Level	+28.57	+1528.57
Main Drains		FS @ Building Line	+31.28.57	
Sewer < 3000		Top/Toe of Batter	+1028.57	+1028.57
Sewer ≥ 3000		Top Ret. Wall Level	+128.57	
Water (DW)		100yr Flood Level	+128.57	
Water (NDW)		Fill Proposed (<0.3m/±0.3m)		
House Drain		Cut Proposed		
Property Inlet		Asphalt Surface Prop		
Street Sign		Concrete Surface Prop		
PSM		Concrete Surface Prop (Paths/Driveways/Slabs)		
Rock Ret Wall		Tree To Be Removed		
Sleeper Ret Wall		Tree To Be Retained with Tree Protection Zone (TPZ)		
Conduits 50mm				
Conduits 100mm				
Street Tree without/with Passive Irrigation (Refer Detail)				
Ex Drains				
Ex Water DW/NDW				
Ex Sewer/Gas				
Ex Elect/Comm				
Ex Optic Fibre				

**PLAN**  
SCALE 1:500

AMENDMENTS		breese pitt dixon pty. ltd. land surveyors civil engineers		1/19 cato street hawthorn east, 3123 telephone 8823 2300 fax no. 8823 2310	
MELWAY REF.	354-C-12	<b>ASPIRE ESTATE STAGE 27 LAYOUT PLAN</b>		MUNICIPALITY <b>MELTON</b>	
SURVEY	BPD			REFERENCE <b>8226 E/27</b>	
DESIGN	J.B			SHEET 01 OF 14	
DRAWN	I.W			P3	
VER	DATE	REMARKS	CHECKED C. HAGEN	SCALE AS SHOWN	DATUM AHD
					DATE JULY '21

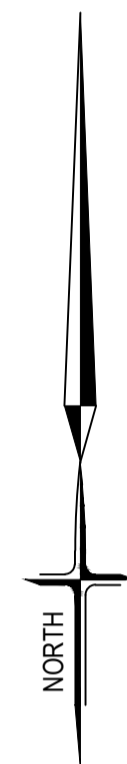

PLAN  
NOT TO SCALE

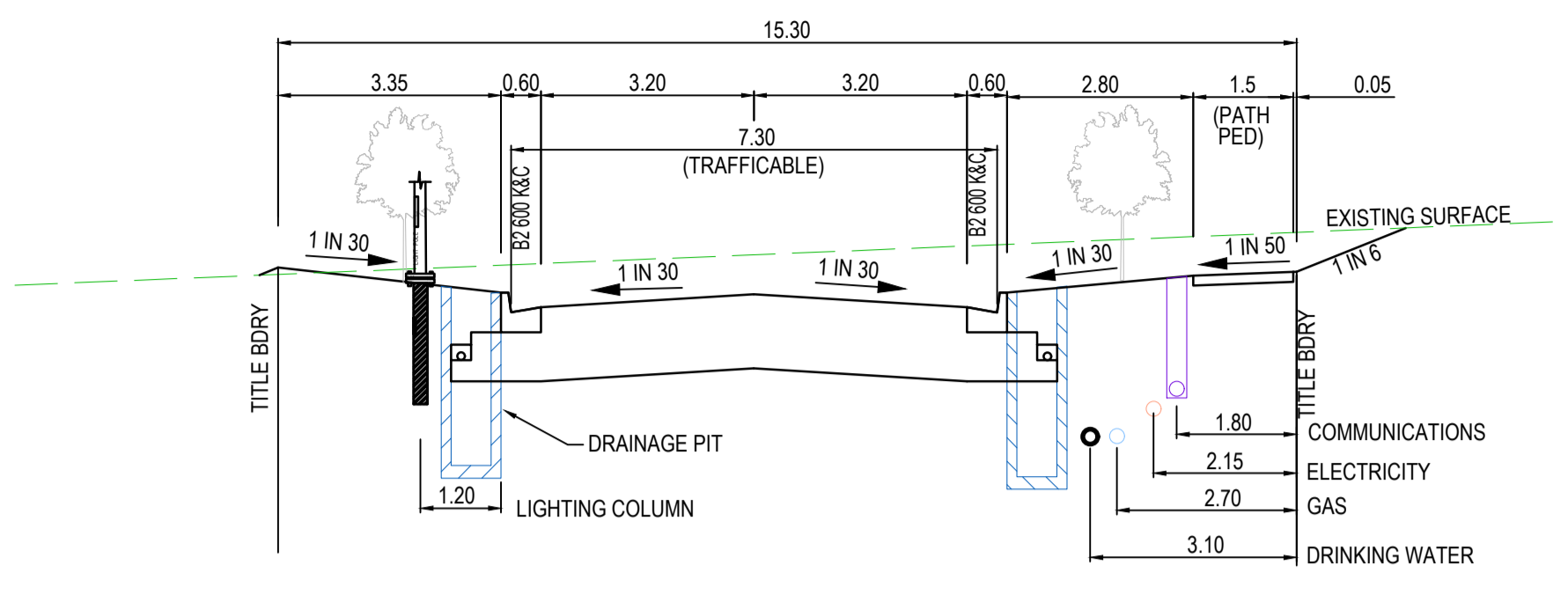

SLAVKO DRIVE (Lots 2724-2729)  
TYPICAL SECTION A - A  
15.3m ROAD RESERVE  
LOCAL ACCESS STREET

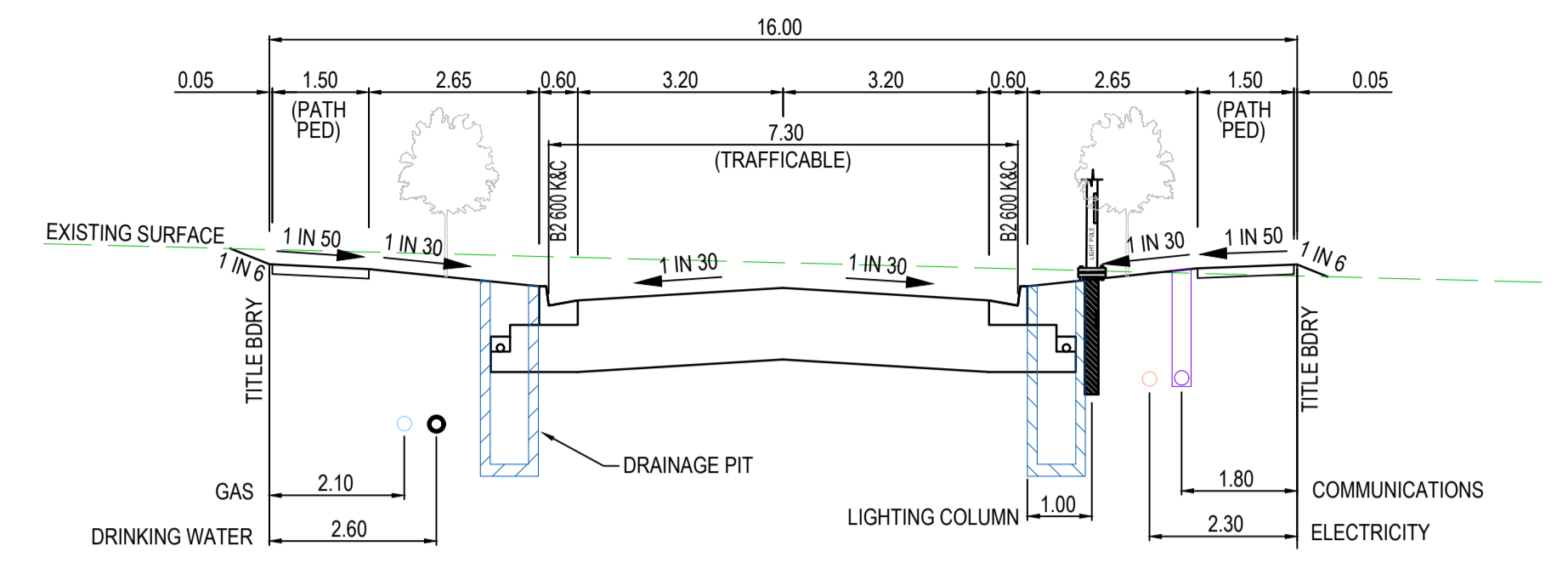

SLAVKO DRIVE (Lots 2701-2723) & FRANCA AVENUE  
TYPICAL SECTION B - B  
16.0m ROAD RESERVE  
LOCAL ACCESS STREET

TYPICAL CROSS SECTIONS

SCALE HORIZONTAL 1:100  
VERTICAL 1:50

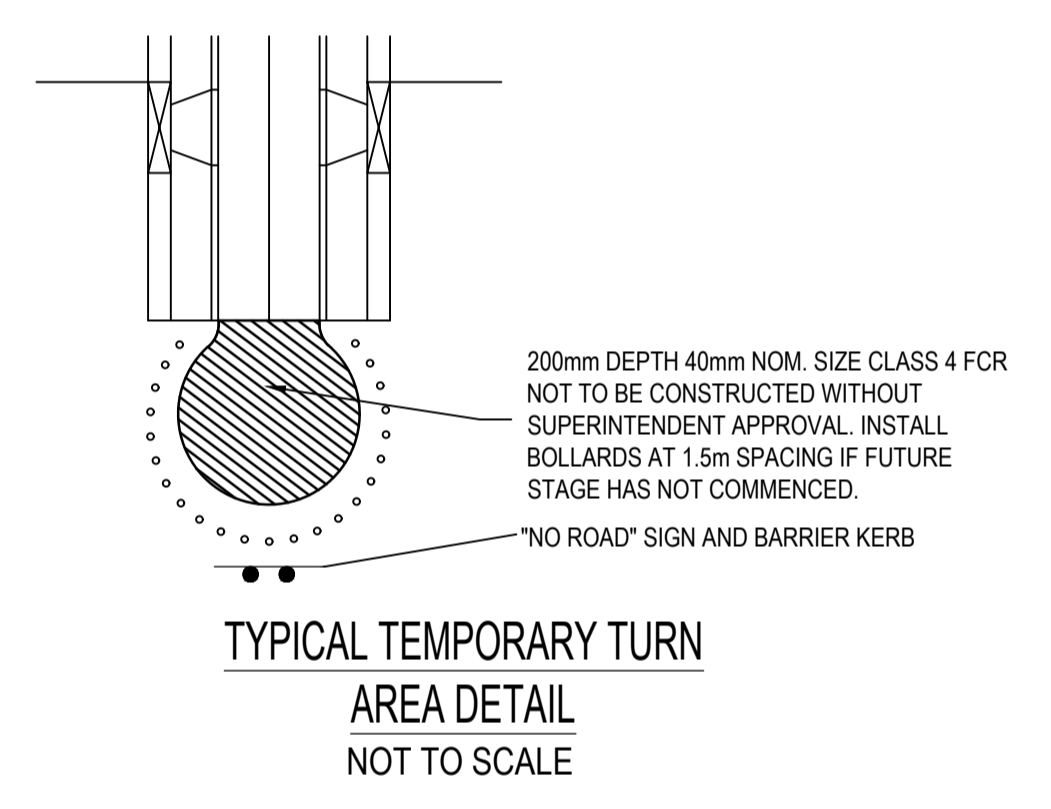

TYPICAL TEMPORARY TURN  
AREA DETAIL  
NOT TO SCALE

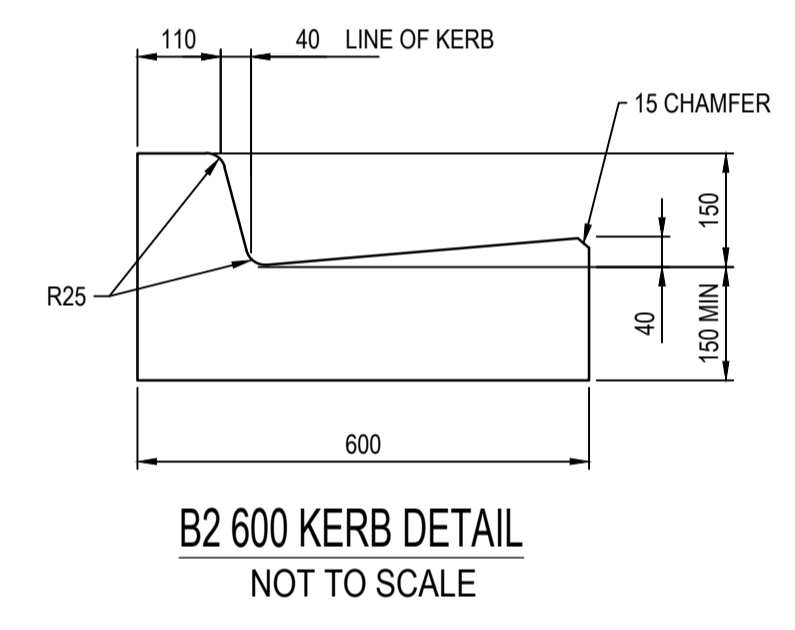

B2 600 KERB DETAIL  
NOT TO SCALE

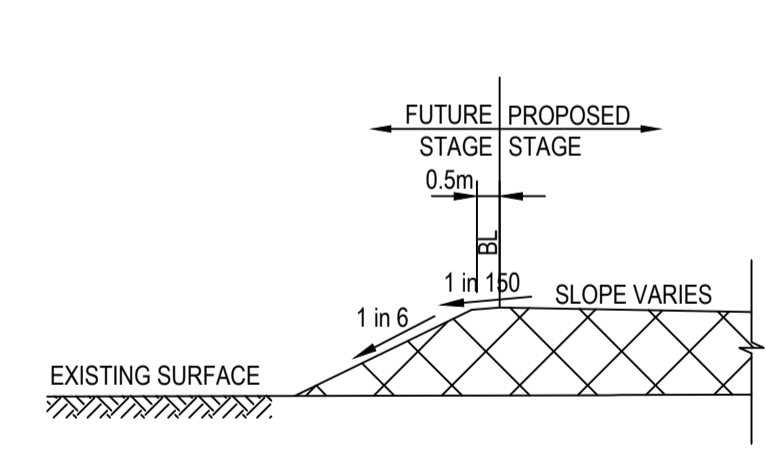

TYPICAL SECTION  
WHEN IN FILL ON BOUNDARY  
OF FUTURE STAGE  
NOT TO SCALE

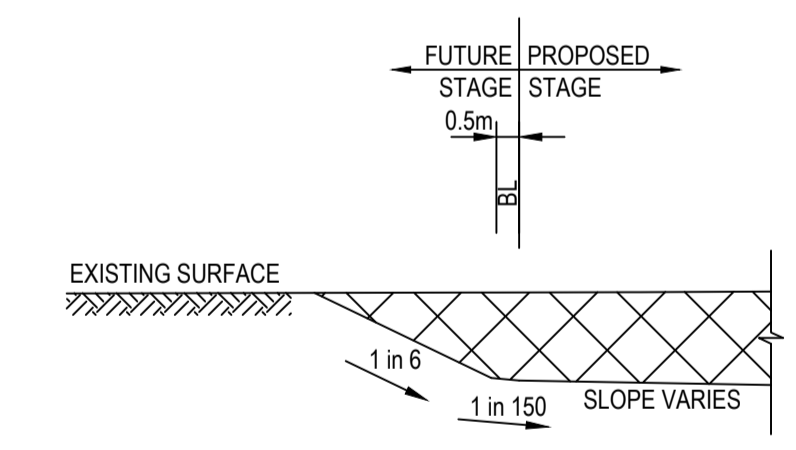

TYPICAL SECTION  
WHEN IN CUT ON BOUNDARY  
OF FUTURE STAGE  
NOT TO SCALE

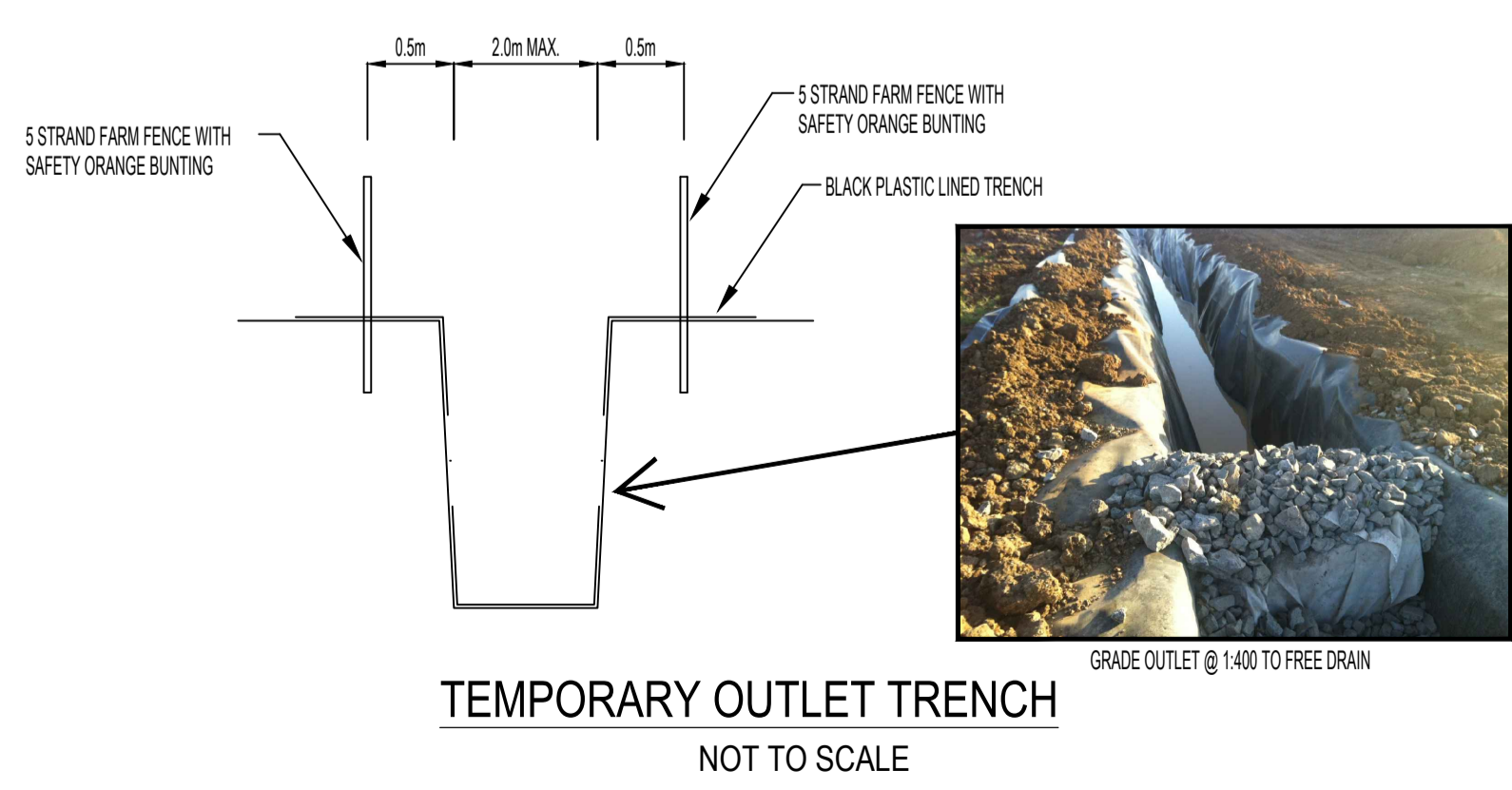

TEMPORARY OUTLET TRENCH  
NOT TO SCALE

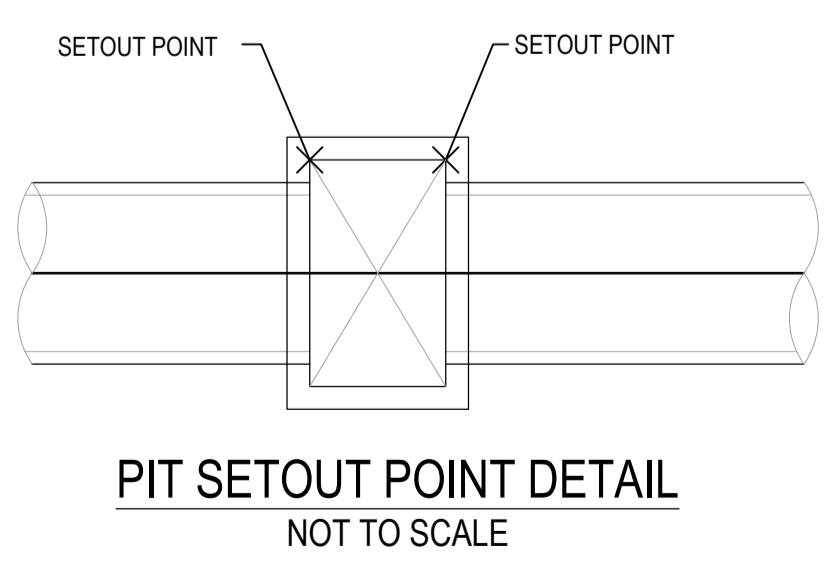

PIT SETOUT POINT DETAIL  
NOT TO SCALE

MELTON  
APPROVED  
DETAILED ENGINEERING PLANS  
Nihal Jayasekara  
ENGINEERING SERVICES  
Date: 26/11/2021

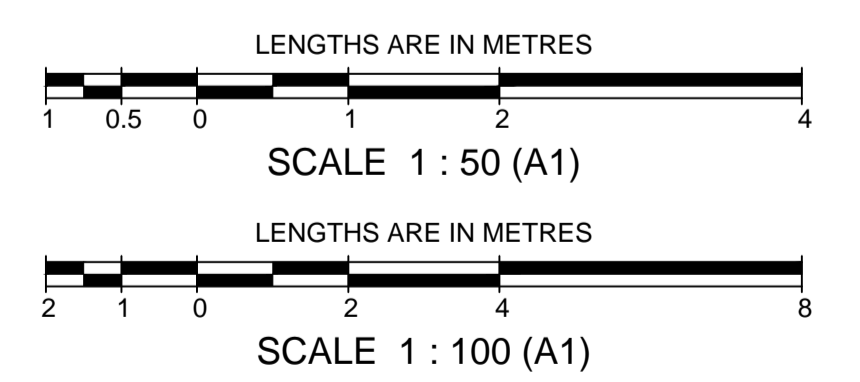

AMENDMENTS		breese pitt dixon pty. ltd. land surveyors civil engineers		1/19 cato street hawthorn east, 3123 telephone 8823 2300 fax no. 8823 2310		
VER	DATE	REMARKS	MELWAY REF. 354-C-12	ASPIRE ESTATE STAGE 27 TYPICAL CROSS SECTIONS		
			SURVEY BPD			MUNICIPALITY MELTON
			DESIGN J.B			REFERENCE 8226 E/27
			DRAWN I.W			
			CHECKED C. HAGEN	SCALE AS SHOWN	DATUM AHD	
				DATE JULY '21	SHEET 02 OF 14 P3	

- a) 20mm COMPACTED DEPTH 7mm NOMINAL SIZE TYPE 'L' ASPHALT WITH C320 BINDER
- b) 30mm COMPACTED DEPTH 10mm NOMINAL SIZE TYPE 'N' ASPHALT WITH C320 BINDER
- c) 10mm SAMI SEAL WITH CLASS S18RF BINDER AND BITUMINOUS PRIME
- d) 140mm COMPACTED DEPTH 20mm NOMINAL SIZE CLASS 2 FINE CRUSHED ROCK, COMPACTED TO AT LEAST 98% MODIFIED DRY DENSITY RATIO WITH A MEAN VALUE OF AT LEAST 100% MODIFIED DRY DENSITY RATIO AND WITHIN 1% OF THE MODIFIED OPTIMUM MOISTURE CONTENT
- e) 100mm COMPACTED DEPTH 20mm NOMINAL SIZE CLASS 3 FINE CRUSHED ROCK, COMPACTED TO AT LEAST 95% MODIFIED DRY DENSITY RATIO WITH A MEAN VALUE OF AT LEAST 98% MODIFIED DRY DENSITY RATIO AND WITHIN 1% OF THE MODIFIED OPTIMUM MOISTURE CONTENT
- f) 150mm CAPPING LAYER - COMPACTED DEPTH SELECT GRANULAR MATERIAL WITH A MINIMUM SOAKED CBR OF 10% COMPACTED TO 98% STANDARD DRY DENSITY RATIO WITH A MEAN VALUE OF AT LEAST 100% STANDARD DRY DENSITY RATIO AND WITHIN 1% OF THE STANDARD OPTIMUM MOISTURE CONTENT AND A PERCENTAGE SWELL < 1.5%
- g) 150mm CONSTRUCTION LAYER - SELECT GRANULAR MATERIAL WITH A MINIMUM SOAKED CBR OF 10% COMPACTED TO 98% STANDARD DRY DENSITY RATIO WITH A MEAN VALUE OF AT LEAST 100% STANDARD DRY DENSITY RATIO AND WITHIN 1% OF THE STANDARD OPTIMUM MOISTURE CONTENT AND A PERCENTAGE SWELL OF >1.5%
- h) SUBGRADE - NATURAL SILTY CLAY TESTED TO CONFIRM AN IN-SITU CBR OF AT LEAST 2% OR APPROVED FILL COMPACTED TO AT LEAST 100% STANDARD DRY DENSITY RATIO (SOAKED CBR >2%) WITHIN 2% OF THE STANDARD OPTIMUM MOISTURE CONTENT.

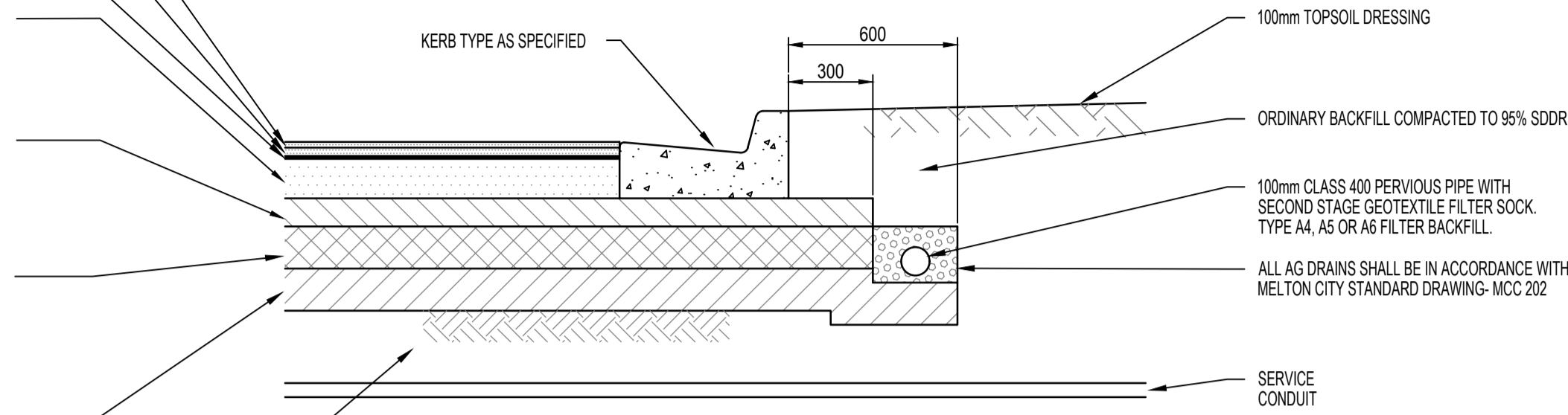

**PAVEMENT DETAILS**  
ALL OTHER ROADS - 600mm DEPTH  
NOT TO SCALE

**SPECIFICATION FOR SAMI SEAL**

THE SAMI TREATMENT SHOULD CONSIST OF A SIZE 10 SPRAYED SEAL USING CLASS S18RF BITUMEN CRUMB RUBBER BINDER PLACED AT AN APPLICATION RATE > 1.8l/m<sup>2</sup> AND COVERED WITH A LIGHT APPLICATION OF PRE-COATED SIZE 10 AGGREGATE. THE CLASS S18RF BINDER SHALL BE PRODUCED USING NOT LESS THAN 20 PARTS OF CRUMB RUBBER (18%) BY MASS OF BINDER. THE VOLUME OF CARRIER OIL USED BEFORE ANY CUTTING OIL IS ADDED SHALL NOT EXCEED 4 PARTS BY VOLUME OF BINDER.

IT IS IMPORTANT THAT THERE IS NO LOOSE AGGREGATE REMAINING ON THE SAMI SURFACE WHEN THE STRUCTURAL COURSE ASPHALT IS PLACED SO AS TO ENSURE A STRONG BOND BETWEEN THE SAMI TREATMENT AND THE SUBSEQUENT ASPHALT LAYER. THE SAMI TREATMENT SHALL BE PRECEDED BY PLACEMENT OF A BITUMINOUS PRIME, AND NOT A PRIMER SEAL, APPLIED TO THE UNDERLYING UNBOUND BASE MATERIAL.

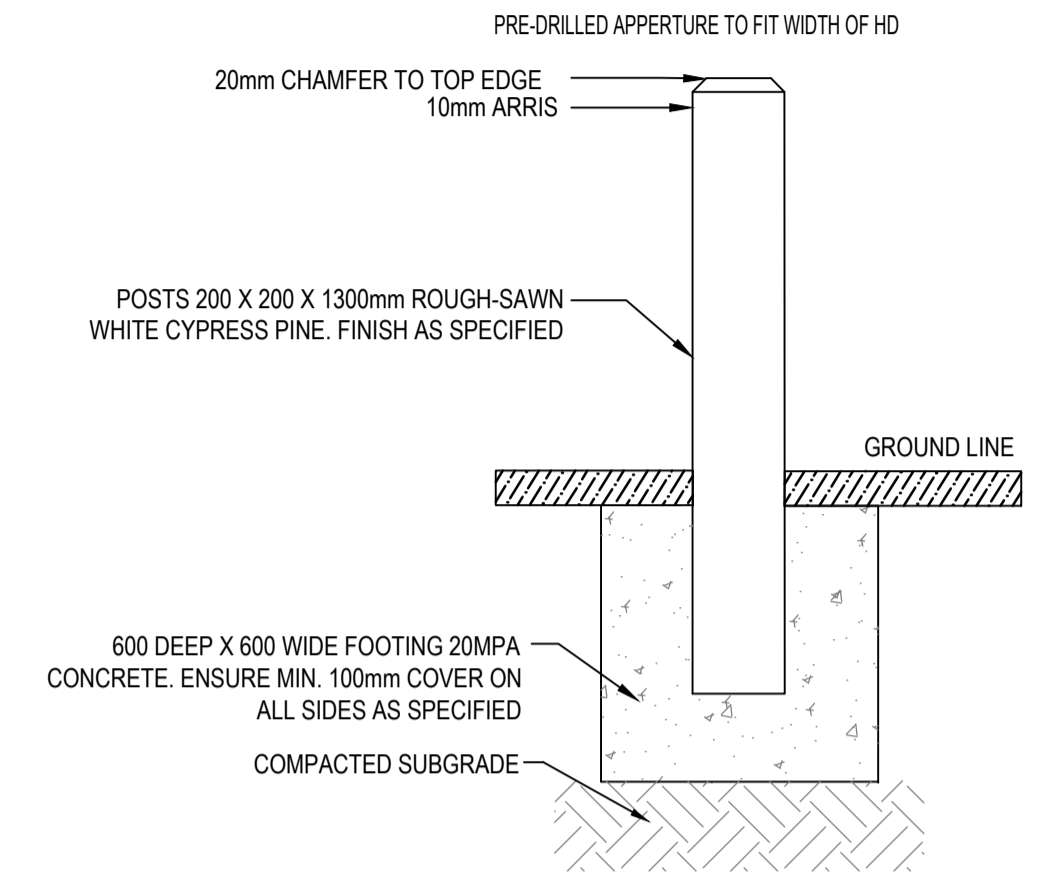

**TYPICAL BOLLARD DETAIL**  
NOT TO SCALE

**GENERAL NOTES**

1. CONSTRUCTION PLANS MUST BE ACCOMPANIED BY THE APPROVED SPECIFICATION. NO WORK IS TO COMMENCE WITHOUT EVIDENCE OF POSSESSION OF EACH.
2. ALL WORKS TO BE CARRIED OUT TO STANDARD DRAWINGS AND SPECIFICATION AS APPROVED BY CITY OF MELTON AND TO THE SATISFACTION OF THE ENGINEER AND THE MUNICIPAL ENGINEER. IN CASE OF A DISPUTE THE SPECIFICATION MUST TAKE PRECEDENCE.
3. COUNCIL TO BE NOTIFIED SEVEN (7) CLEAR DAYS PRIOR TO COMMENCEMENT OF WORKS.
4. PROPERTY INLETS ARE TO BE PLACED 1.0m FROM THE LOW CORNER OF LOT UNLESS OTHERWISE SHOWN. MINIMUM COVER TO BE 400mm. REFER VPA STD DWGS EDCM701, EDCM702 & EDCM703.
5. LOTS DENOTED THUS 25H ARE TO BE PROVIDED WITH A 100mm DIA. HOUSE DRAIN PLACED 5.5m FROM LOW CORNER OF LOT UNLESS OTHERWISE SHOWN. REFER VPA STD DWGS EDCM701 & EDCM703.
6. AGRICULTURAL PIPE DRAINS, AS PER COUNCIL STD DWG MCC202, TO BE PLACED BEHIND ALL KERB AND CHANNEL AND BUFFER PITCHERS AND WHERE DIRECTED BY THE ENGINEER.
7. DRAINAGE AND PITS TO BE SET OUT FROM OFFSETS SHOWN RATHER THAN FROM PIPE CHAINAGES. CENTRELINE OF PITS AT TP's TO BE OFFSET 1.00 METRE.
8. ALL 150mm TO 750mm DIA. TO BE R.C.(RRJ) AND 825mm DIA. AND GREATER TO BE R.C.(FJ). PIPES LAID ON A CURVE TO BE RRJ. ALL CONCRETE PIPES TO BE CLASS 2 UNLESS OTHERWISE SPECIFIED.
9. WHERE DRAINAGE PIPES ARE LOCATED WITHIN NATURE STRIPS, THE TRENCH SHALL BE BACKFILLED WITH COMPACTED CLASS 3 F.C.R. UP TO A LEVEL WHERE THE 45deg. INFLUENCE LINE FROM THE B.O.K. INTERSECTS WITH THE NEAREST TRENCH SIDE. PROVIDE CRUSHED ROCK BACKFILL WHERE DRAINAGE CROSSES BELOW FOOTPATHS.
10. PIPE TRENCHES WITHIN THE ROAD RESERVE MUST BE BACKFILLED WITH 20mm CLASS 3 CRUSHED ROCK TO A RELATIVE COMPACTION OF 97% OF THE MAXIMUM FOUND IN THE STANDARD COMPACTION TEST FOR THE FOLLOWING:
  - BENEATH THE ROAD OR DRIVEWAY PAVEMENT TO THE UNDERSIDE OF THE PAVEMENT.
  - ADJACENT TO KERBING OR CONCRETE WORKS TO A LEVEL THAT IS NOT AFFECTED BY A 45 DEGREE ANGLE OF REPOSE FROM THE NEAR LOWER EDGE. (TRENCHES TO BE BACKFILLED IN LAYERS NOT EXCEEDING 200mm LOOSE.)
11. PRIOR TO COMMENCEMENT OF WORKS ON SITE, THE CONTRACTOR MUST ENSURE THAT ALL MATTERS RELATING TO THE OCCUPATIONAL HEALTH AND SAFETY ACT 2004, INCLUDING ALL RELEVANT REGULATIONS, HAVE BEEN ADDRESSED. IN PARTICULAR, THE REQUIRED NOTIFICATIONS MUST BE CONVEYED TO THE VICTORIAN WORKCOVER AUTHORITY - HEALTH & SAFETY DIVISION WITH RESPECT TO TRENCHING OPERATIONS. DETAILS OF THE CONTRACTORS OCCUPATIONAL HEALTH & SAFETY PROCEDURES MUST BE LODGED WITH THE SUPERINTENDENT PRIOR TO COMMENCEMENT OF WORKS.
12. BATTERS SHALL BE 1 IN 6 FOR FILL AND 1 IN 6 FOR CUT UNLESS OTHERWISE SHOWN.
13. ON COMPLETION THE CONTRACTOR IS RESPONSIBLE FOR THE REMOVAL OF ALL RUBBISH AND SPOIL FROM SITE.
14. LOTS TO BE GRADED AND LEFT CLEAN TO THE SATISFACTION OF THE ENGINEER, ALL LOTS TO BE 1 IN 150 MINIMUM SLOPE.
15. ALL RESERVE AREAS ARE TO BE SMOOTHED, GRADED AND TOPSOILED WHERE REQUIRED WITH A 100mm COMPACTED LAYER OF TOPSOIL AND SEEDED USING AN APPROVED SEED MIX AND METHOD OF SOWING SUCH THAT THE SURFACE IS SELF-DRAINING, STONE FREE AND ABLE TO BE MAINTAINED BY CONVENTIONAL MOWING EQUIPMENT.
16. FILL AREAS ARE TO BE STRIPPED OF TOPSOIL, FILLED AND TOPSOIL REPLACED TO OBTAIN FINAL FILL LEVELS AS SHOWN ON THE PLANS. FILLING TO BE CLEAN CLAY COMPACTED TO A DRY DENSITY NOT LESS THAN 95% OF THE MAXIMUM DRY DENSITY VALUE DETERMINED BY THE STANDARD COMPACTION TEST IN ACCORDANCE WITH AUSTRALIAN STANDARD AS1289.5.2.1-2003. CONTROL TESTING TO COMPLY WITH AS3798-2007 APPENDIX B, LEVEL 1.
17. THE CONTRACTOR IS RESPONSIBLE FOR ENSURING THAT ALL IMPORTED FILL MATERIAL, INCLUDING TOPSOIL, SATISFIES THE DESCRIPTION FOR CLEAN FILL MATERIAL IN EPA BULLETIN PUBLICATION No. 448 (SEPT '95) AND SUBSEQUENT REVISIONS. THE CONTRACTOR SHALL PROVIDE VERIFICATION INCLUDING TEST CERTIFICATES TO THE SUPERVISING ENGINEER.
18. EARTH FILL IS TO BE COMPACTED TO A RELATIVE COMPACTION COMPARED TO A STANDARD COMPACTION TEST AS SPECIFIED BY VICROADS CORPORATION OF:
  - 100% FOR ALL FILL MATERIAL AND MATERIAL UNDER FILL THAT IS LESS THAN 450mm FROM THE SURFACE.
  - 97% FOR ALL FILL NOT COVERED AS ABOVE.
19. NATURE STRIP AND AREAS OF CUT ARE TO BE TOPSOILED AND GRASSED TO THE SATISFACTION OF THE ENGINEER. MINIMUM DEPTH TO BE 100mm.
20. ALL NATIVE TREES AND SHRUBS TO BE RETAINED UNLESS ROAD CONSTRUCTION NECESSITATES THEIR REMOVAL OR REMOVAL IS DIRECTED BY THE ENGINEER. NO EXCAVATION WITHIN 5m OF ANY EXISTING NATIVE TREE WITHOUT APPROVAL OF THE ENGINEER.
21. WHERE WORKS ARE IN THE VICINITY OF EXISTING SERVICES THESE SERVICES ARE TO BE LOCATED AND THE VARIOUS AUTHORITIES NOTIFIED, BY THE CONTRACTOR, PRIOR TO THE COMMENCEMENT OF WORKS.
22. SERVICES CONDUITS ARE TO BE PROVIDED AT 90deg TO KERB AND CHANNEL UNLESS OTHERWISE SHOWN AND THE LOCATION IS TO BE MARKED ON THE FACE OF KERB. ALL SERVICE CONDUITS TO BE MINIMUM STANDARD OF CLASS 6, WITH A MINIMUM COVER OF 75mm ABOVE TOP OF CONDUIT TO SUB GRADE LEVEL, AND A SIZE SUITABLE TO SERVICE BUT NOT LESS THAN 50mm.
23. WATER AND GAS CONDUITS TO BE CONSTRUCTED ACROSS NATURE STRIPS AFTER ELECTRICAL CABLE WORK IS COMPLETED.
24. THE WATER CONDUIT OFFSET FROM THE LOT BOUNDARY IS GIVEN ON THE WATER RETICULATION PLAN. THE CONTRACTOR MUST CONSTRUCT CONDUITS TO ACCORD WITH THE GIVEN OFFSET AND ENSURE THAT THE CONCRETE MARKS THE KERB AND FOOTPATH EXACTLY ABOVE THE CONDUIT.
25. TELSTRANBN Co TO BE NOTIFIED SEVEN (7) DAYS PRIOR TO CONCRETE WORKS BEING PLACED.
26. VEHICLE CROSSINGS TO BE OFFSET 0.75m FROM SIDE BOUNDARIES AND EASEMENTS UNLESS OTHERWISE SHOWN AND A MINIMUM OF 0.75m CLEAR OF PITS. VEHICULAR CROSSINGS TO BE CONSTRUCTED IN ACCORDANCE WITH CITY OF MELTON STANDARD DRAWINGS MSC501 TO MSC506. VEHICULAR CROSSINGS TO BE CONSTRUCTED IN ACCORDANCE WITH VPA STANDARD DRAWINGS EDCM501 & EDCM502. ACROSS THE WINGED SECTION CONTRACTOR TO PROVIDE TWO 450mm LONG N12 DEFORMED BARS, CENTRALLY LOCATED, AT 300mm CENTRES.
27. ALL RESIDENTIAL FOOTPATHS SHALL BE 1.5m WIDE (MIN.) AND SHARED PEDESTRIAN/CYCLE PATHS SHALL BE 2.5m (MIN.). CONCRETE PATHS ARE TO BE 125mm THICK REINFORCED WITH SL72 MESH 50mm TOP COVER AND UNDERLAIN BY 50mm OF CLASS 3 CR. REFER VPA STD DWG EDCM401.
28. PRAM CROSSINGS ARE TO BE CONSTRUCTED WHERE FOOTPATHS CONNECT TO THE BACK OF KERB & CHANNEL. REFER TO COUNCIL STD DWG MCC403.
29. STREET SIGNS ARE TO BE CONSTRUCTED IN ACCORDANCE WITH COUNCIL STANDARDS.
30. THE CONTRACTOR SHALL TO THE SATISFACTION OF THE ENGINEER AND THE MUNICIPAL ENGINEER, PROVIDE AND MAINTAIN INCLUSIVE OF STREET SIGNS, ALL NECESSARY REGULATORY SIGNS, WARNING SIGNS, LIGHTING, LINE MARKING AND BARRICADING TO COMPLY WITH THE REQUIREMENTS OF VICROADS SIGNING CODE OF PRACTICE.
31. THE CONTRACTOR IS TO SUPPLY AND ERECT ALL RELEVANT STREET SIGNAGE AND LINE MARKING AS PART OF THE CONTRACT IN ACCORDANCE WITH VICROADS SPECIFICATION SECTIONS 710 & 722 AND AS1742.1, 2 & 3.
32. ALL ROADS TO BE CONSTRUCTED WITH B2 KERB & CHANNEL UNLESS OTHERWISE SHOWN. REFER VPA STD DWG EDCM301.
33. THE CONTRACTOR IS RESPONSIBLE FOR OBTAINING A ROAD OPENING PERMIT FOR WORKS IN PREVIOUSLY CONSTRUCTED ROADWAYS.
34. IF BLASTING IS REQUIRED THE CONTRACTOR IS RESPONSIBLE FOR OBTAINING A PERMIT TO BLAST AND MAINTAINING SAFETY REGULATIONS ON SITE IN COMPLIANCE WITH THE EXPLOSIVES ACT 1960. THE PERSON WHO IS USING THE EXPLOSIVES ON THE SITE IS TO BE A HOLDER OF A CURRENT PERMIT TO USE EXPLOSIVES ISSUED UNDER THE EXPLOSIVES ACT 1960.
35. PATTERNED CONCRETE TO BE DOWELLED INTO ADJACENT KERB AND CHANNEL AT 300mm CTS USING 450mm LONG S12 BARS. ONE END OF DOWEL TO BE SLEEVED OR GREASED.
36. THE RELATIVE COMPACTION OF CRUSHED ROCK SHALL BE COMPLETED AT THE OPTIMUM MOISTURE CONTENT TO A DRY DENSITY (BASED ON THE PERCENTAGE OF THE MAXIMUM DRY DENSITY OBTAINED IN THE MODIFIED COMPACTION TEST) AS BELOW:
  - FOR DEPTH 0-100mm BELOW TOP OF BASE: RELATIVE COMPACTION = 100%
  - FOR DEPTH 100-300mm BELOW TOP OF BASE: RELATIVE COMPACTION = 98%
  - FOR DEPTH OVER 300mm BELOW TOP OF BASE: RELATIVE COMPACTION = 97%
37. THE SUBGRADE BELOW ALL PAVEMENTS SHALL BE COMPACTED TO A DRY DENSITY OF NOT LESS THAN 100% OF THE MAXIMUM DRY DENSITY OBTAINED IN THE STANDARD COMPACTION TEST IN AREAS OF CUT TO A DEPTH OF 150mm AND IN AREAS OF FILL TO A DEPTH OF 450mm.
38. CONCRETE TO HAVE A 28 DAY STRENGTH OF 25 Mpa.
39. ALL SPLAYS ARE 3.00m X 3.00m UNLESS OTHERWISE SHOWN.
40. LL LEVELS ARE TO THE AUSTRALIAN HEIGHT DATUM (A.H.D.)
41. EXISTING DAM OR WATERCOURSES TO BE EXCAVATED TO A FIRM BASE AND BACKFILLED AS SPECIFIED. DEVELOPER'S CONSULTANT TO BE NOTIFIED WHEN THE DAM OR WATERCOURSES ARE EXCAVATED TO A FIRM BASE. NO FILLING IS TO BE PLACED PRIOR TO DAMS BEING INSPECTED AND LEVELS TAKEN. BACKFILLING IS TO BE CARRIED OUT TO THE SATISFACTION OF THE COUNCIL SUPERVISING ENGINEER.
42. THE CONTRACTOR MUST COMPLETE A LEVEL CHECK BETWEEN ALL TBM'S TO VERIFY LEVEL VALUES BEFORE COMMENCEMENT OF WORKS. ALL TBM'S AND CONTROL POINTS ARE TO BE MAINTAINED AND PROTECTED AT ALL TIMES DURING CONSTRUCTION. SHOULD ANY MARKS BE DISTURBED, THE CONTRACTOR WILL IMMEDIATELY NOTIFY THE DEVELOPER'S CONSULTANT TO ARRANGE RE-INSTATEMENT AT THE CONTRACTORS EXPENSE.
43. PRIOR TO COMMENCEMENT OF WORKS, THE CONTRACTOR MUST SUBMIT A SMP TO THE DEVELOPER'S CONSULTANT FOR APPROVAL. THE CONTRACTOR MUST COMPLY WITH THE RECOMMENDATIONS OF THE ENVIRONMENT PROTECTION AUTHORITY PUBLICATION No.275 "CONSTRUCTION TECHNIQUES FOR SEDIMENT POLLUTION CONTROL" AND MW SITE ENVIRONMENTAL MANAGEMENT POLICY 3.8.2. APPROPRIATE SILTATION CONTROL IS TO BE MAINTAINED THROUGHOUT THE CONSTRUCTION AND MAINTENANCE PERIOD OF THE WORKS.
44. PROVIDE 1.8m HIGH PALING FENCE ALONG ANY COMMON BOUNDARY BETWEEN A LOT AND MUNICIPAL RESERVE. PALINGS TO BE ON THE RESERVE SIDE AND STAINED IN A DARK GREEN COLOUR ON THE SIDE FACING THE RESERVE TO THE SATISFACTION OF COUNCIL.
45. PROVIDE TEMPORARY SAFETY BARRIER FENCE (FARM FENCE AS PER MW STD. DWG. 725114/203) ALONG FULL EXTENT OF OUTFALL DRAINS. SAFETY FENCE TO REMAIN UNTIL PERMANENT UNDERGROUND DRAINAGE IS INSTALLED.



**PIT SCHEDULE NOTES**

1. WHERE PIT HAUNCHING IS REQUIRED, INTERNAL PIT WALL DIMENSIONS MUST ALLOW 50mm CLEARANCE EACH SIDE OF PIPE OUTSIDE DIAMETER, INCLUDING ANGULAR PIPE ENTRY TO PIT. MINIMUM DIMENSIONS OF PIT BASE ARE TO BE AS PER SIZES SPECIFIED IN THE PIT SCHEDULE. TOP OF PIT OPENING FOR ALL PITS WITH HAUNCHES TO BE 900mm x 600mm.
2. PIT BASE TO BE SHAPED TO MATCH LOWER HALF OF PIPE WHERE DROP ACROSS PIT IS LESS THAN 50mm.
3. ALL PITS LOCATED WITHIN THE ROAD RESERVE (INDICATED THUS \*) SHALL BE PROVIDED WITH TERRA FIRMA OR APPROVED EQUIVALENT PIT LID WITH A LOCKABLE COVER.

AMENDMENTS				<b>breese pitt dixon pty. ltd.</b> land surveyors civil engineers	1/19 cato street hawthorn east, 3123 telephone 8823 2300 fax no. 8823 2310	
					MELWAY REF. 354-C-12	MUNICIPALITY MELTON
					SURVEY BPD	REFERENCE 8226 E/27
					DESIGN J.B	
				DRAWN I.W		
				CHECKED C. HAGEN		
				SCALE AS SHOWN	DATUM AHD	
				DATE JULY '21	SHEET 03 OF 14	
					P3	



CURVE SETOUT DETAILS	
I	90.000
R	8.6
Arc	13.509
A	2.519
B	1.864
X	3.291
Y	2.790
I	3.377
Mid Level	124.022

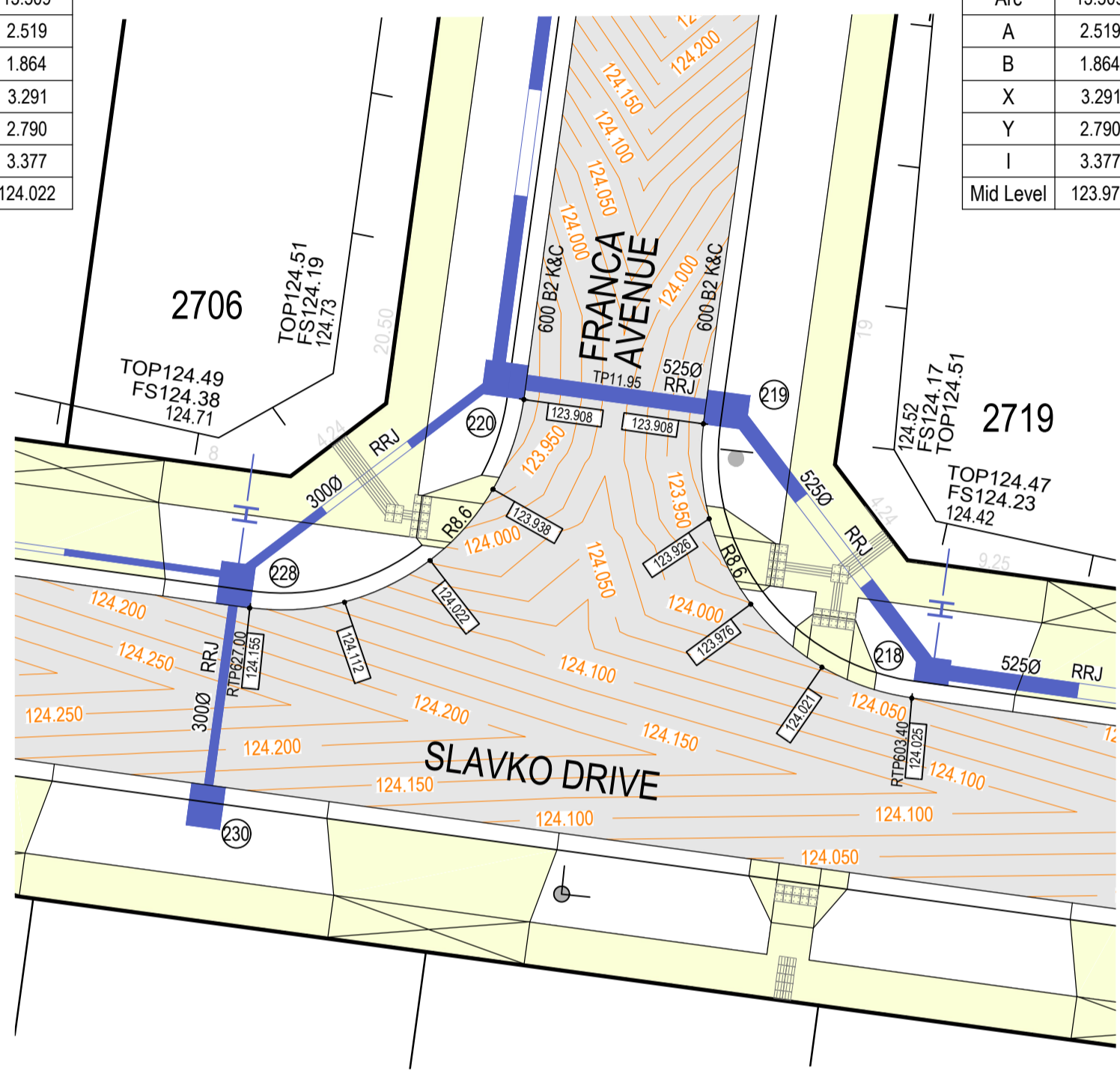

CURVE SETOUT DETAILS	
I	90.000
R	8.6
Arc	13.509
A	2.519
B	1.864
X	3.291
Y	2.790
I	3.377
Mid Level	123.976

CURVE SETOUT DETAILS	
I	89.953
R	8.6
Arc	13.502
A	2.516
B	1.862
X	3.289
Y	2.789
I	3.375
Mid Level	123.594

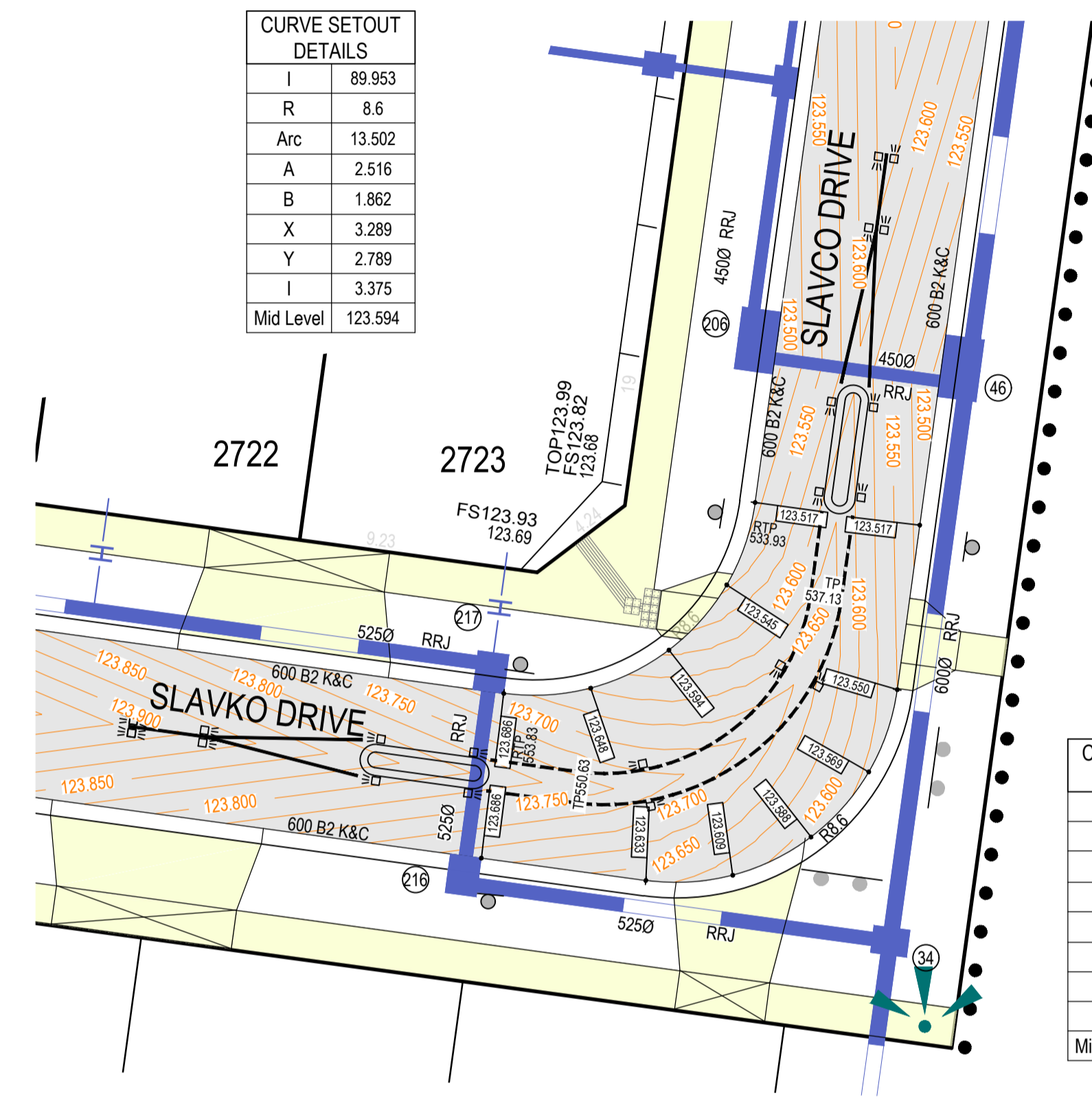

CURVE SETOUT DETAILS	
I	89.953
R	8.6
Arc	13.502
A	2.516
B	1.862
X	3.289
Y	2.789
I	3.375
Mid Level	123.588

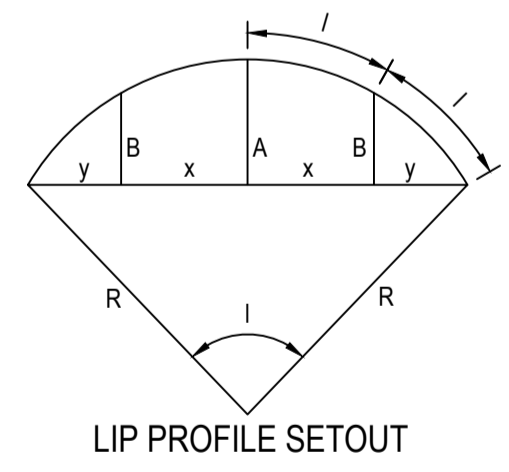

LIP PROFILE SETOUT

  
**APPROVED**  
**DETAILED ENGINEERING PLANS**  
 Nihal Jayasekara  
 ENGINEERING SERVICES  
 Date: 26/11/2021

- NOTES**
- ALL SIGNS TO BE SLEEVED USING A SL27 SLEEVE.
  - INDICATES UNIDIRECTIONAL & BIDIRECTIONAL RRPMS PLACED AT 6.00m CTS
  - HAZARD / DIRECTIONAL TGS'S SHOWN THUS AND FOOTPATH RAMPS SHALL BE CONSTRUCTED IN ACCORDANCE WITH VICROADS STD DWGS SD2031 TO SD2035. TGS'S SHALL CONFORM TO AS1428.4
  - PROVIDE EMERALD GREEN COLOURED HIGH FRICTION SURFACE TREATMENTS ALONG SHARED PATH DENOTED THUS: SURFACE TREATMENT MUST COMPLY WITH VICROADS STANDARD SECTION 430.
  - STREET SIGNS TO HAVE MINIMUM 2 WEDGES IN THE SLEEVES
  - SWLM - INDICATES SOLID WHITE "LONGLIFE" LINE MARKING  
BWLm - INDICATES BROKEN WHITE "LONGLIFE" LINE MARKING
  - RETURN & ELBOW LIP OF KERB CHAINAGES PREFIXED WITH AN "L" (eg LTP35.83)

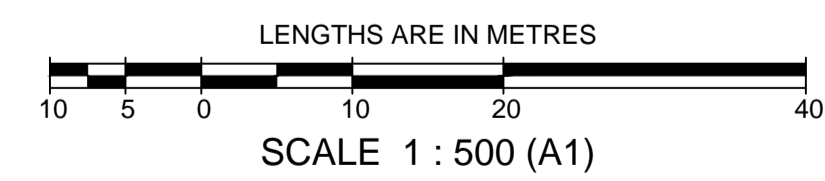

**SYMBOL LEGEND**

Drains	Prop	Prev Stage	Ex/Natural/FS Level	+28.57	+N528.57	+F528.57
Main Drains	—S—	—S—	FS @ Building Line	+31.28.57		
Sewer < 3000	—S—	—S—	Top/Toe of Batter	+10P28.57	+10E28.57	
Sewer ≥ 3000	—S—	—S—	Top Ret. Wall Level	+TW28.57		
Water (DW)	—W—	—W—	100yr Flood Level	+FL28.57		
Water (NDW)	—NDW—	—NDW—	Fill Proposed (<0.3m/≥0.3m)			
House Drain	—H—	—H—	Cut Proposed			
Property Inlet	—P—	—P—	Asphalt Surface Prop			
Street Sign	—S—	—S—	Concrete Surface Prop			
PSM	—P—	—P—	Concrete Surface Prop			
Rock Ret Wall	—R—	—R—	(Paths/Driveways/Slabs)			
Sleeper Ret Wall	—S—	—S—	Tree To Be Removed			
Conduits 50mm	—GW—	—GW—	Tree To Be Retained with			
Conduits 100mm	—W100—	—W100—	Tree Protection Zone (TPZ)			
Street Tree without/with	—T—	—T—				
Passive Irrigation (Refer	—I—	—I—				
Detail)	—I—	—I—				
Ex Drains	—E—	—E—				
Ex Water DW/NDW	—E—	—E—				
Ex Sewer/Gas	—E—	—E—				
Ex Elect/Comm	—E—	—E—				
Ex Optic Fibre	—E—	—E—				

AMENDMENTS	VER	DATE	REMARKS	 <b>breese pitt dixon pty. ltd.</b> land surveyors civil engineers	1/19 cato street hawthorn east, 3123 telephone 8823 2300 fax no. 8823 2310					
	MELWAY REF.	354-C-12	<b>ASPIRE ESTATE</b> <b>STAGE 27</b> <b>INTERSECTION DETAIL PLANS</b>			MUNICIPALITY	MELTON			
	SURVEY	BPD				REFERENCE	8226 E/27			
	DESIGN	J.B								
DRAWN	I.W									
CHECKED	C. HAGEN	SCALE	AS SHOWN	DATUM	AHD	DATE	JULY '21	SHEET	04 OF 14	P3



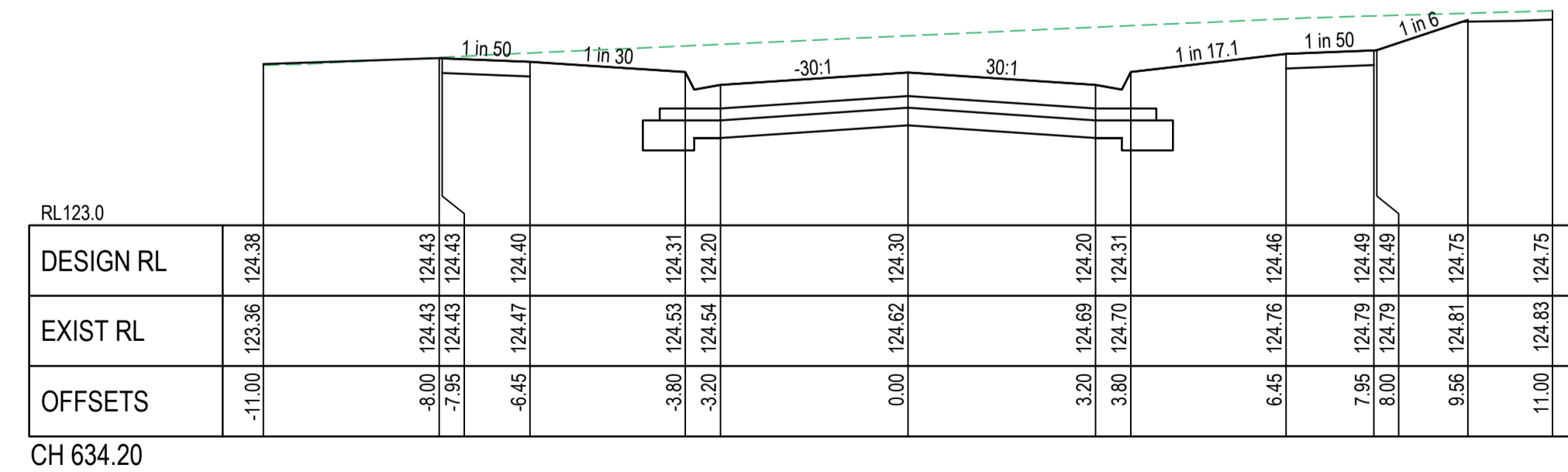
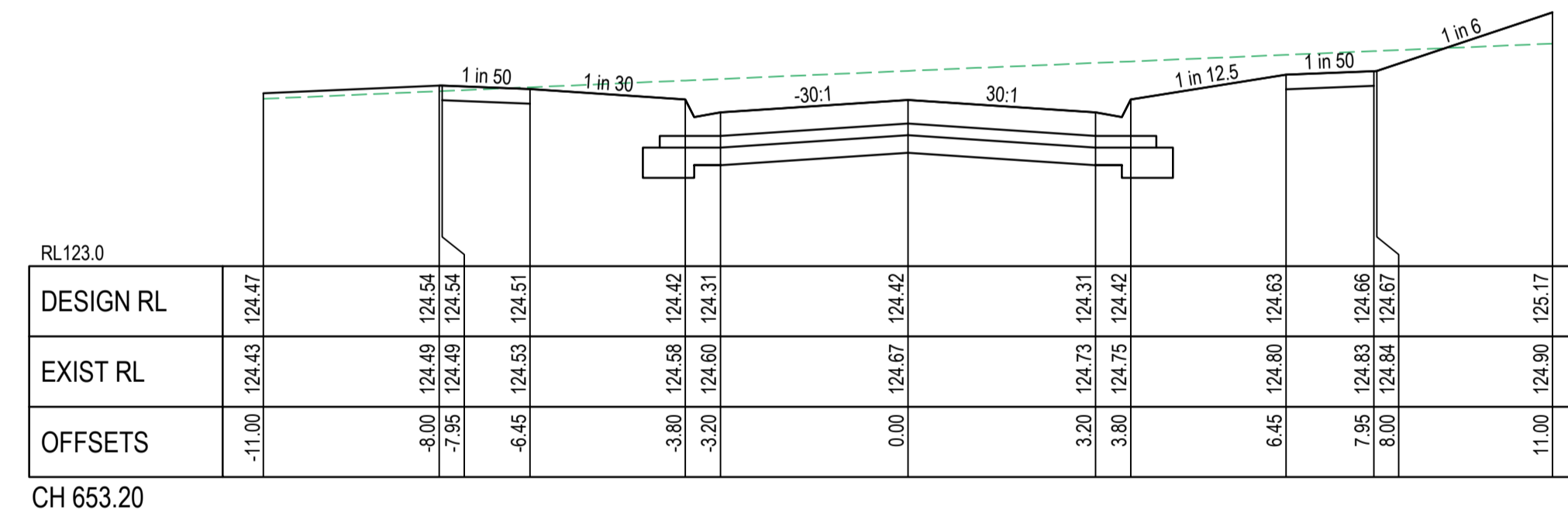
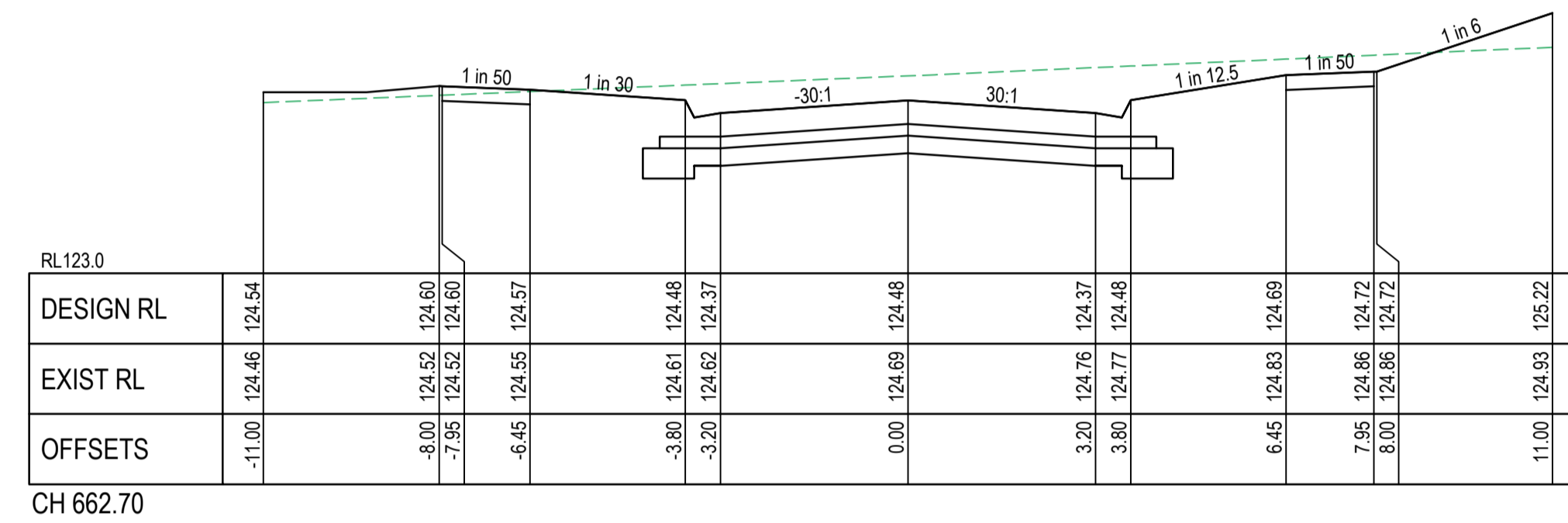
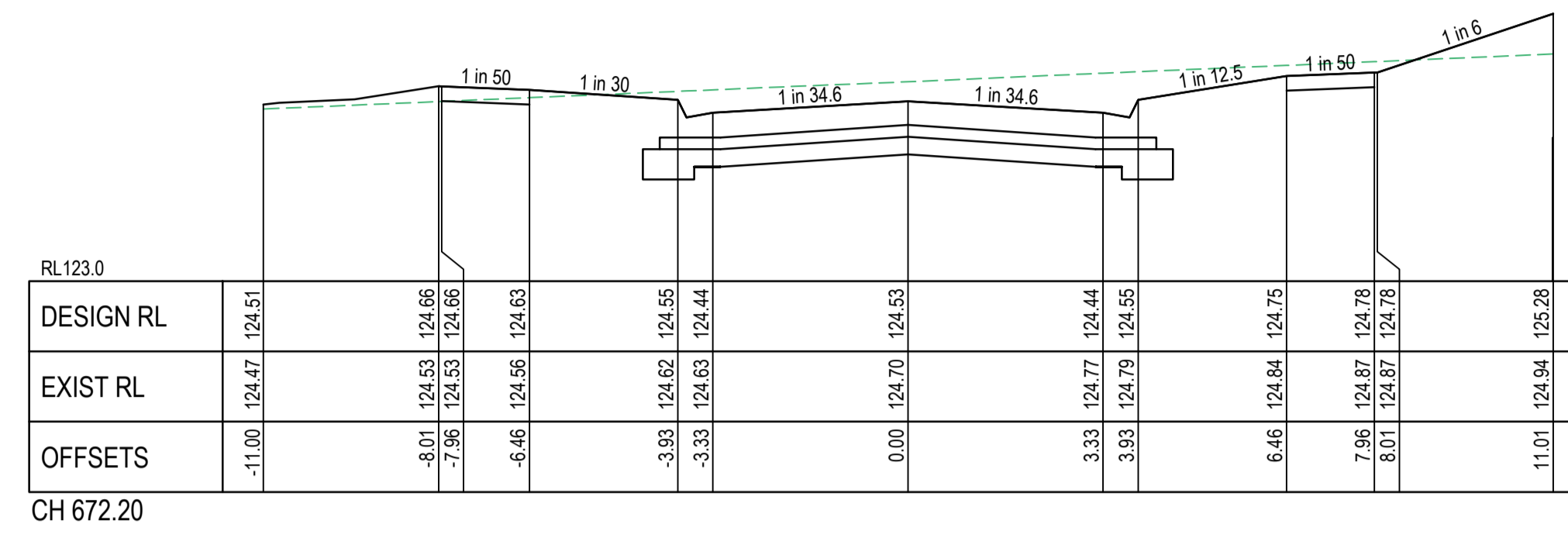
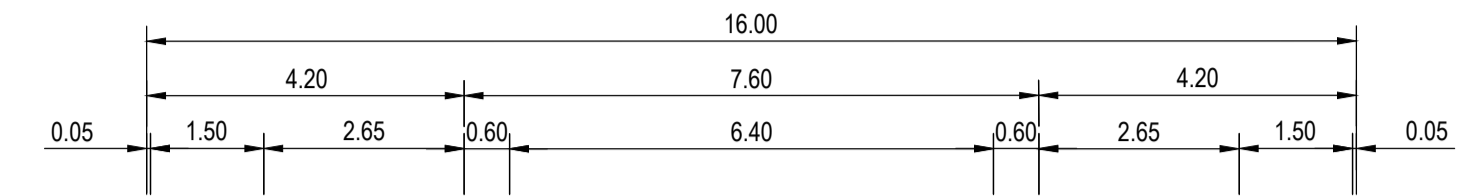
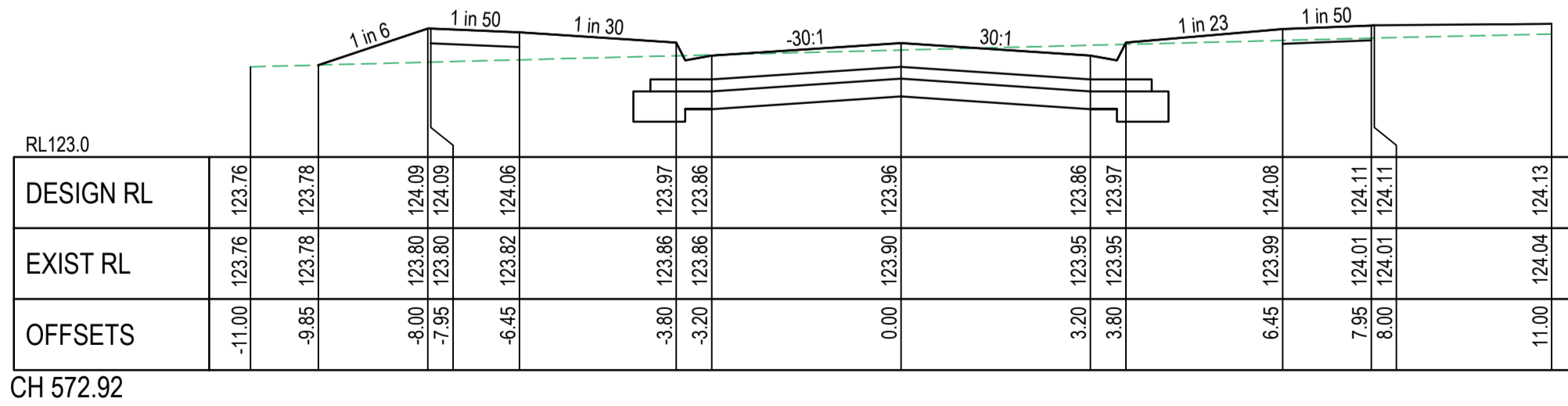
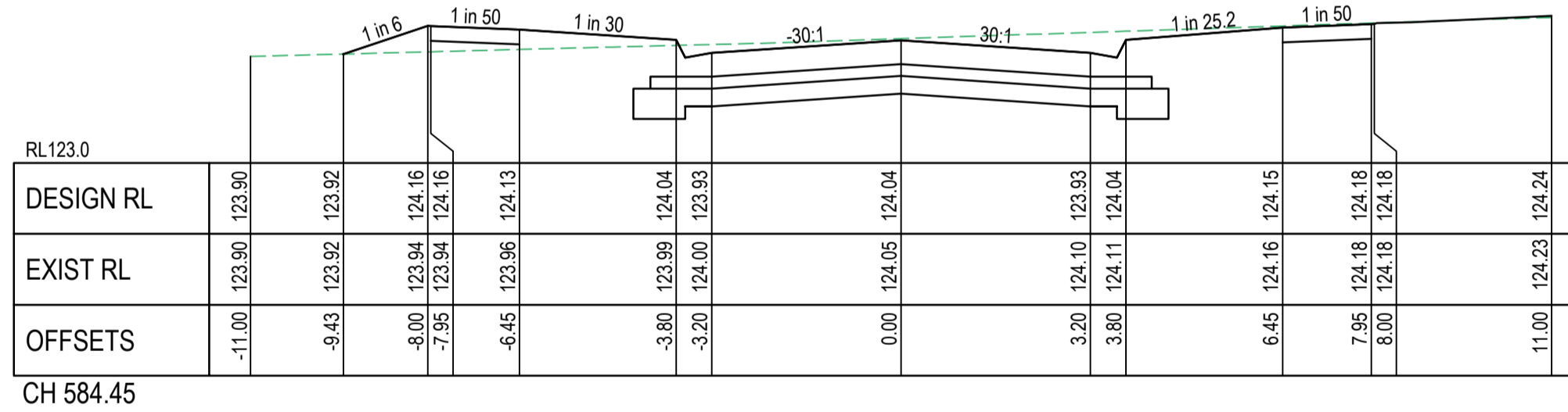
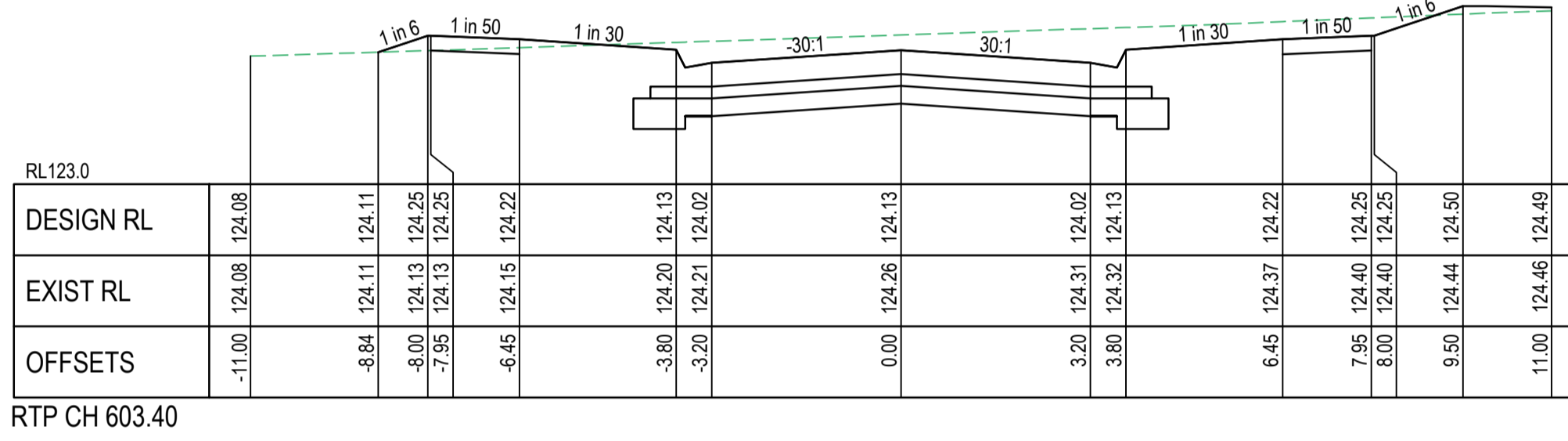
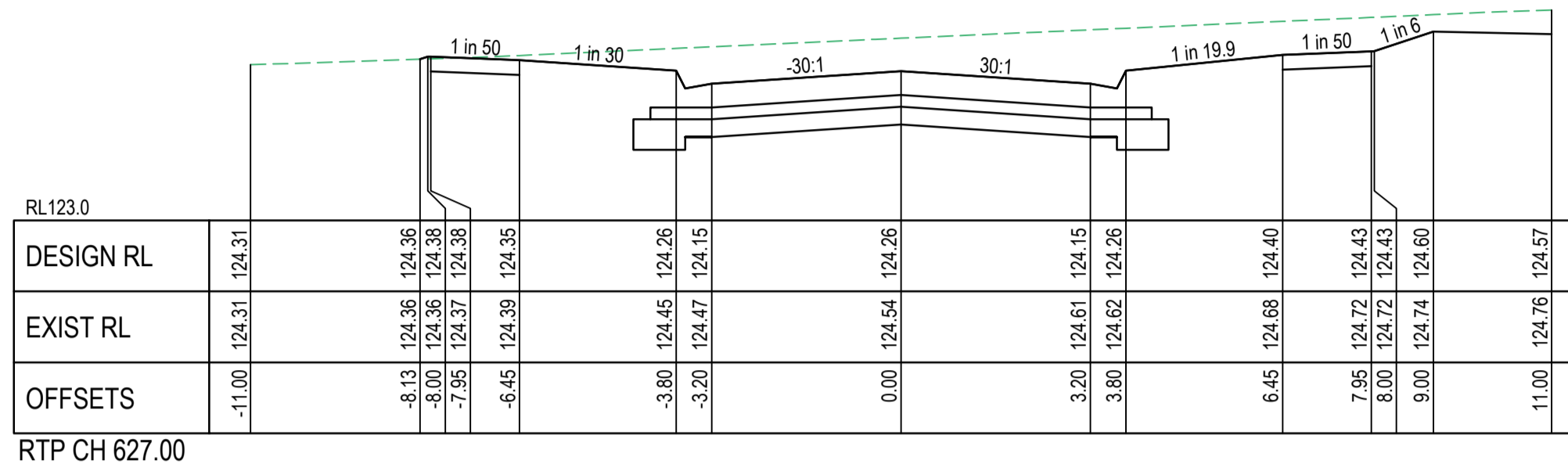
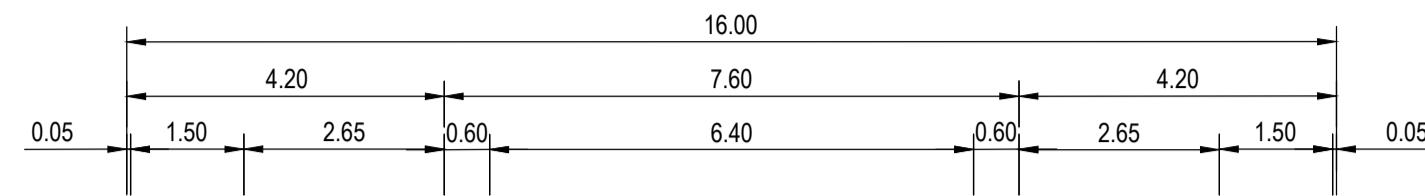

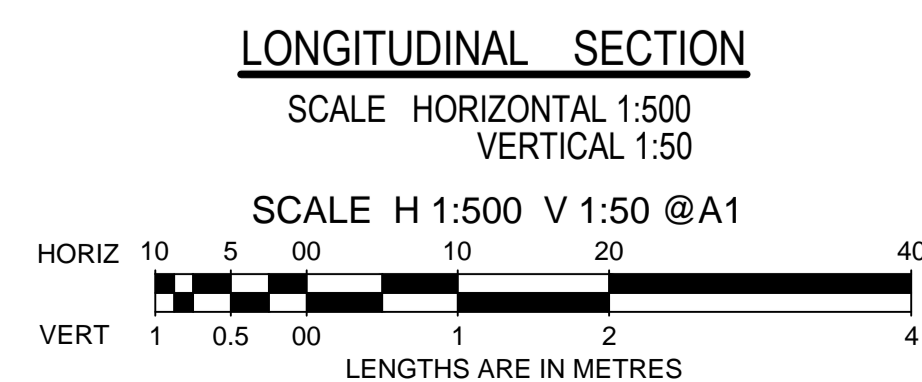
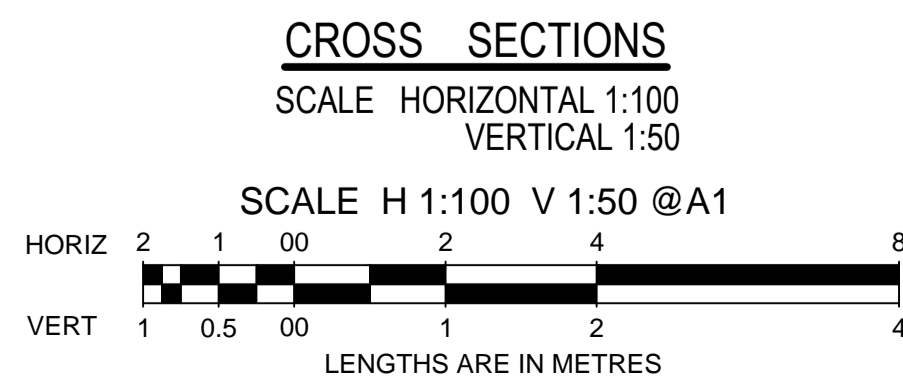

**SLAVKO DRIVE**



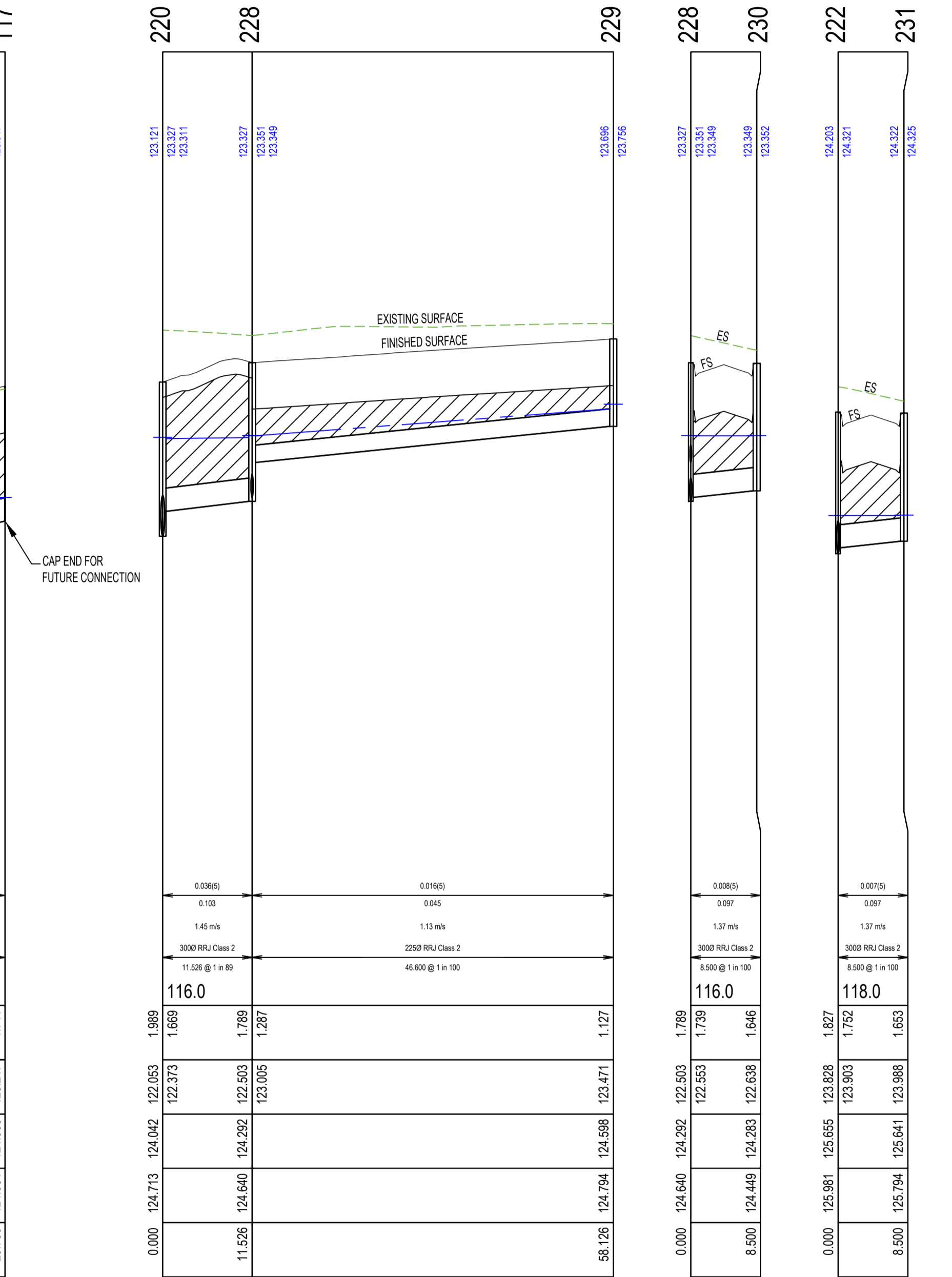
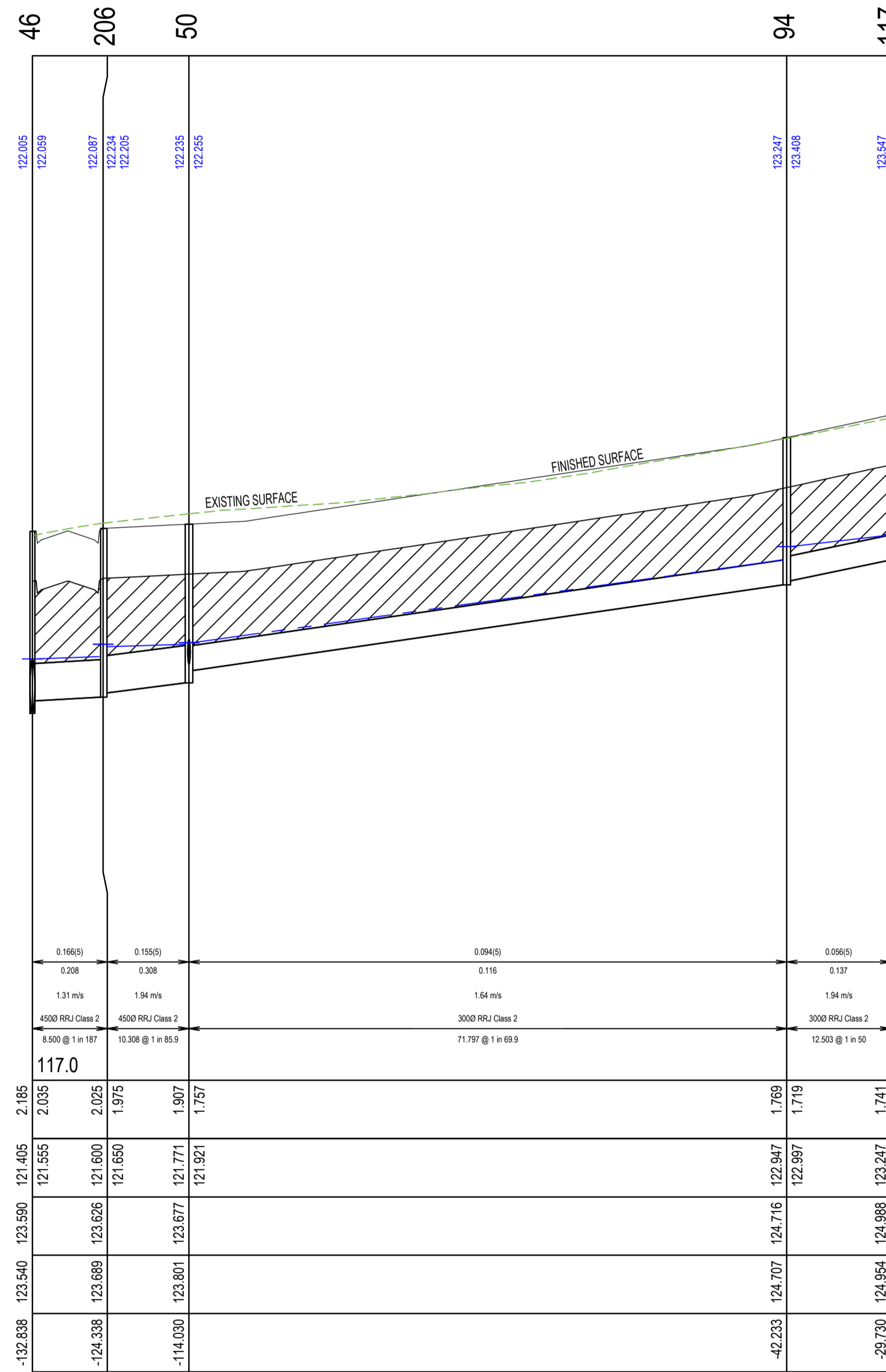
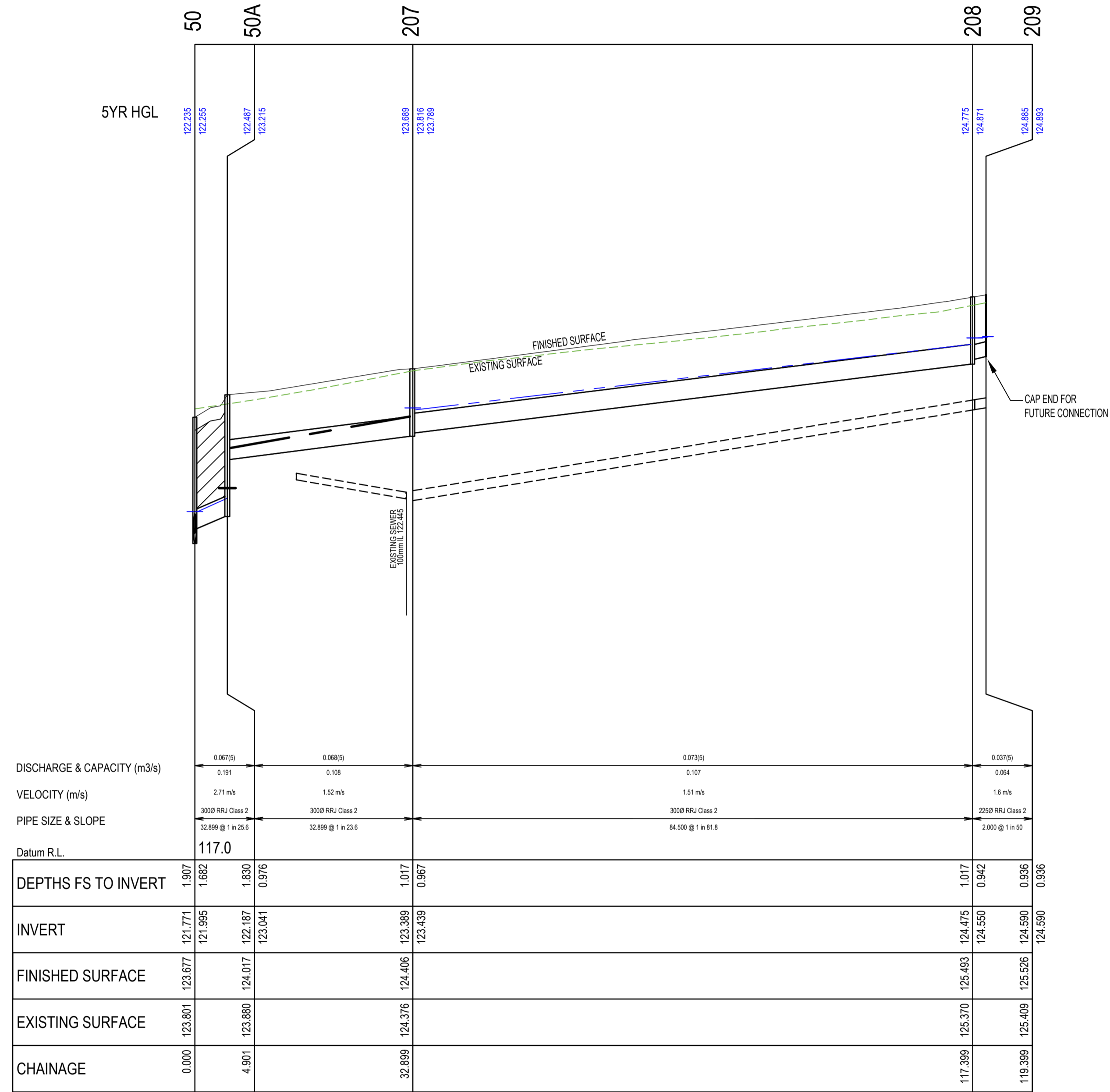

		1/19 cato street hawthorn east, 3123 telephone 8823 2300 fax no. 8823 2310	
MELWAY REF. 354-C-12 SURVEY BPD DESIGN J.B DRAWN I.W		<b>ASPIRE ESTATE</b> <b>STAGE 27</b> <b>SLAVKO DRIVE SHEET 2 OF 2</b>	
MUNICIPALITY <b>MELTON</b>		REFERENCE <b>8226 E/27</b>	
AMENDMENTS VER DATE REMARKS	CHECKED C. HAGEN SCALE AS SHOWN DATUM AHD DATE JULY '21	SHEET 06 OF 14	P3

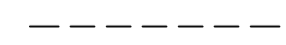

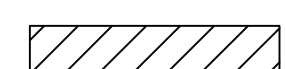

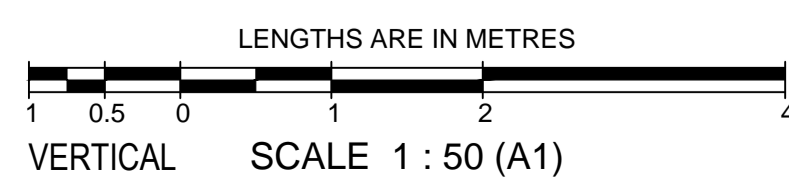
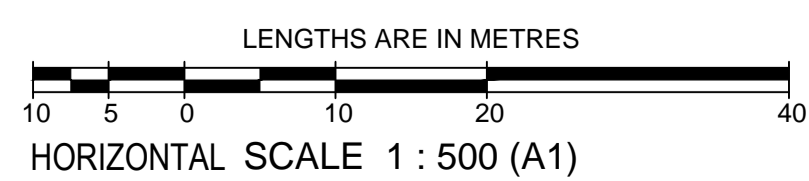
- LEGEND:**
-  EXISTING SURFACE PROFILE
  -  FINISHED SURFACE PROFILE
  -  INDICATES 5YR HGL
  -  INDICATES CRUSHED ROCK BACKFILL





AMENDMENTS			 <b>breese pitt dixon pty. ltd.</b> land surveyors      civil engineers	<b>ASPIRE ESTATE</b> <b>STAGE 27</b> DRAINAGE LONGITUDINAL SECTIONS - SHEET 1	MUNICIPALITY <b>MELTON</b> REFERENCE <b>8226 E/27</b>				
	VER	DATE				REMARKS			
	CHECKED	C. HAGEN				SCALE AS SHOWN	DATUM AHD	DATE JULY '21	SHEET 08 OF 14
									P3

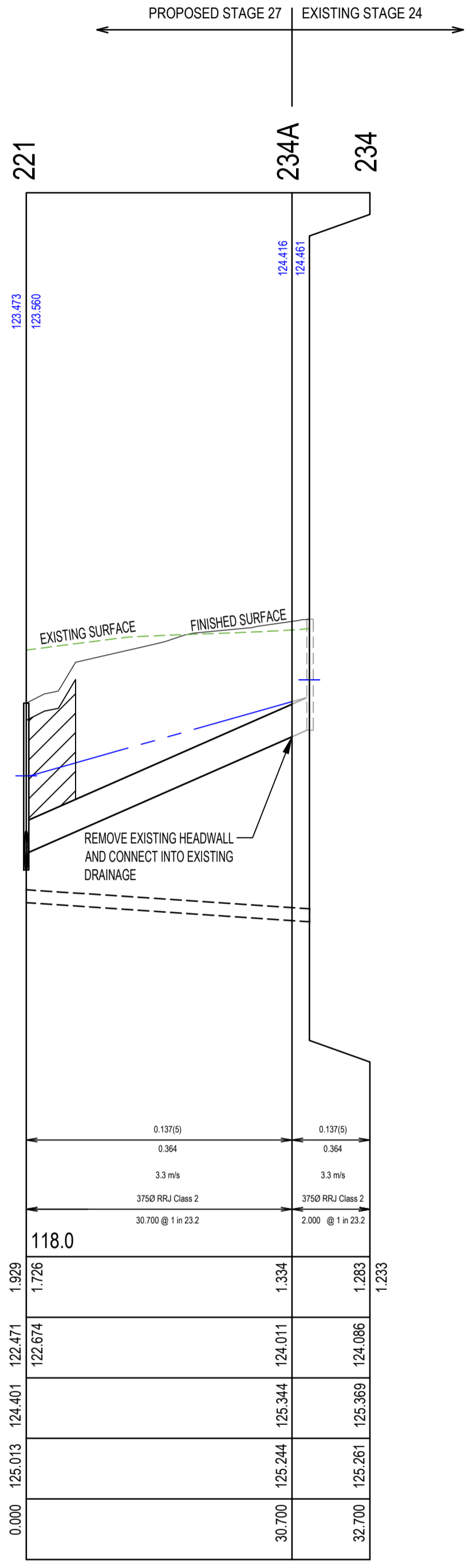
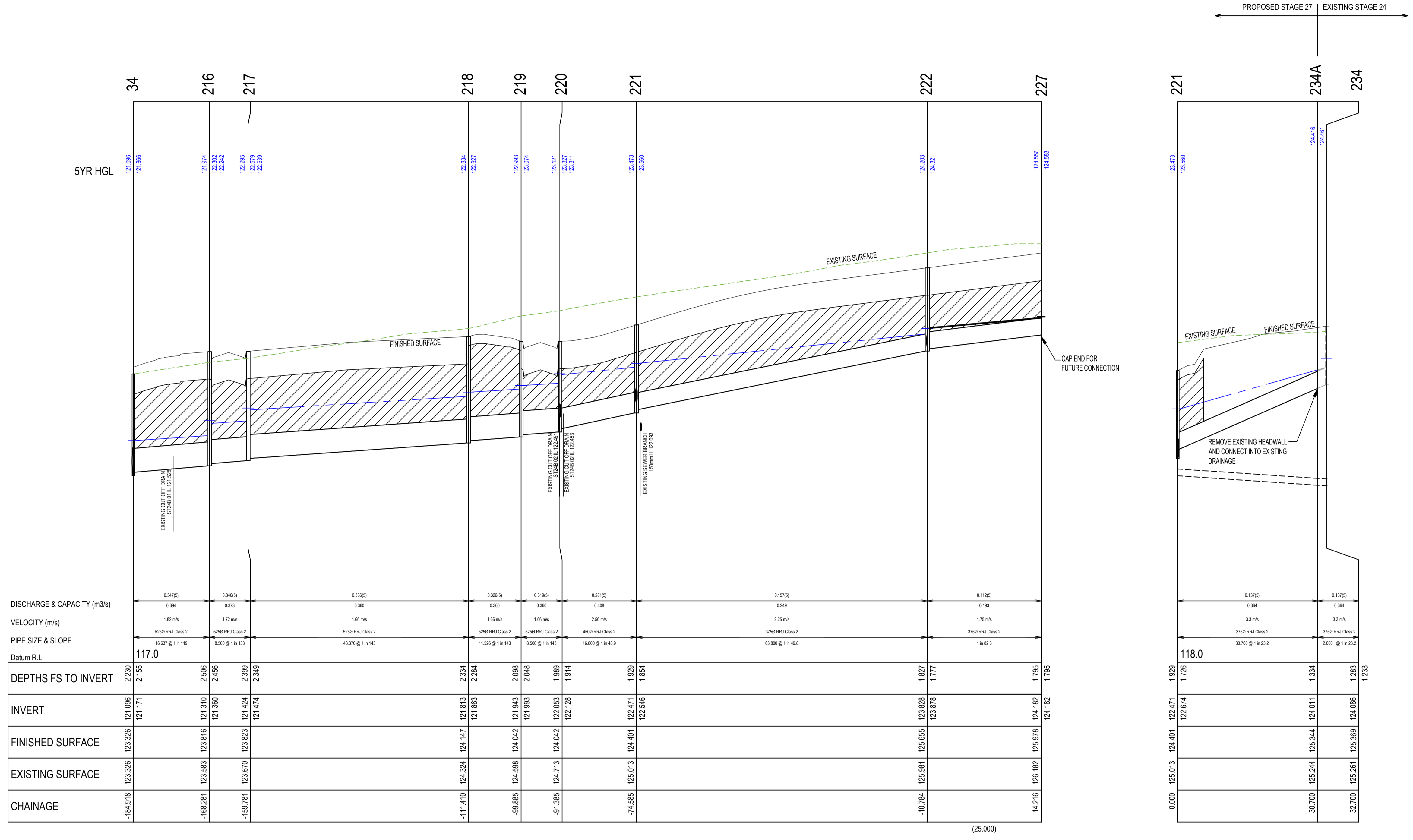



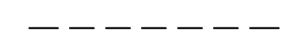

  
**APPROVED**  
**DETAILED ENGINEERING PLANS**  
 Nihal Jayasekara  
 ENGINEERING SERVICES  
 Date: 26/11/2021

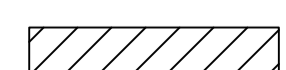
	34	216	217	218	219	220	221	222	227
5YR HGL	121.866 121.866	121.974 122.242 122.242	122.295 122.579 122.539	122.824 122.827	122.893 123.074	123.121 123.327 123.311	123.473 123.360	124.203 124.321	124.567 124.583
DISCHARGE & CAPACITY (m <sup>3</sup> /s)	0.347(5)	0.340(5)	0.336(5)	0.326(5)	0.319(5)	0.360	0.408	0.157(5)	0.112(5)
VELOCITY (m/s)	1.82 m/s	1.72 m/s	1.66 m/s	1.66 m/s	1.66 m/s	2.56 m/s	2.25 m/s	1.75 m/s	3.3 m/s
PIPE SIZE & SLOPE	16.837 @ 1 in 119	8.500 @ 1 in 133	49.370 @ 1 in 143	11.526 @ 1 in 143	8.950 @ 1 in 143	16.800 @ 1 in 49.9	63.800 @ 1 in 49.9	1 in 82.3	
Datum R.L.	117.0								
DEPTHS FS TO INVERT	2.230 2.155	2.506 2.456	2.399 2.349	2.334 2.264	2.098 2.048	1.989 1.914	1.929 1.854	1.827 1.777	1.795 1.735
INVERT	121.096 121.171	121.310 121.360	121.424 121.474	121.813 121.863	121.943 121.993	122.053 122.128	122.471 122.546	123.828 123.878	124.182 124.182
FINISHED SURFACE	123.326	123.816 123.593	123.823 123.670	124.147 124.324	124.042 124.598	124.042 124.713	124.401 125.013	125.655 125.991	125.978 126.182
EXISTING SURFACE	123.326	123.593	123.670	124.324	124.598	124.713	125.013	125.991	126.182
CHAINAGE	-184.918	-168.281	-159.781	-111.410	-99.885	-91.385	-74.685	-10.784	14.216

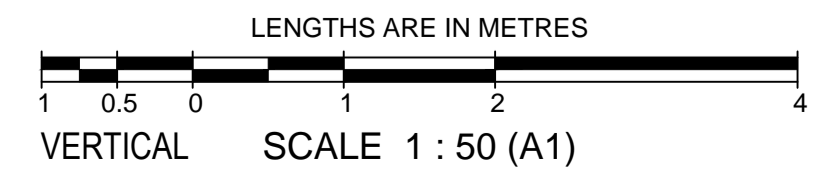
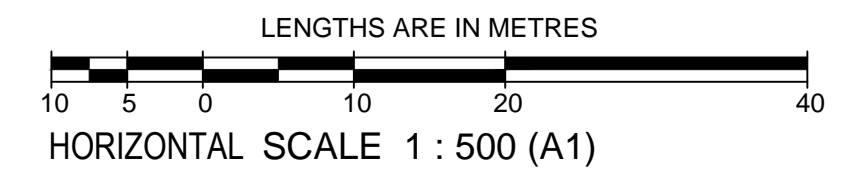
- LEGEND:**
-  EXISTING SURFACE PROFILE
  -  FINISHED SURFACE PROFILE
  -  INDICATES 5YR HGL
  -  INDICATES CRUSHED ROCK BACKFILL



AMENDMENTS			 <b>breese pitt dixon pty. ltd.</b> land surveyors      civil engineers	1/19 cato street hawthorn east, 3123 telephone 8823 2300 fax no. 8823 2310	
	DATE	REMARKS		<b>MELWAY REF. 354-C-12</b> <b>SURVEY BPD</b> <b>DESIGN J.B</b> <b>DRAWN I.W</b>	<b>MUNICIPALITY</b> <b>MELTON</b>
	VER			<b>ASPIRE ESTATE</b> <b>STAGE 27</b> <b>DRAINAGE LONGITUDINAL SECTIONS - SHEET 2</b>	REFERENCE <b>8226 E/27</b>
				<b>SCALE AS SHOWN</b> <b>DATUM AHD</b> <b>DATE JULY '21</b>	SHEET <b>09 OF 14</b> <b>P3</b>

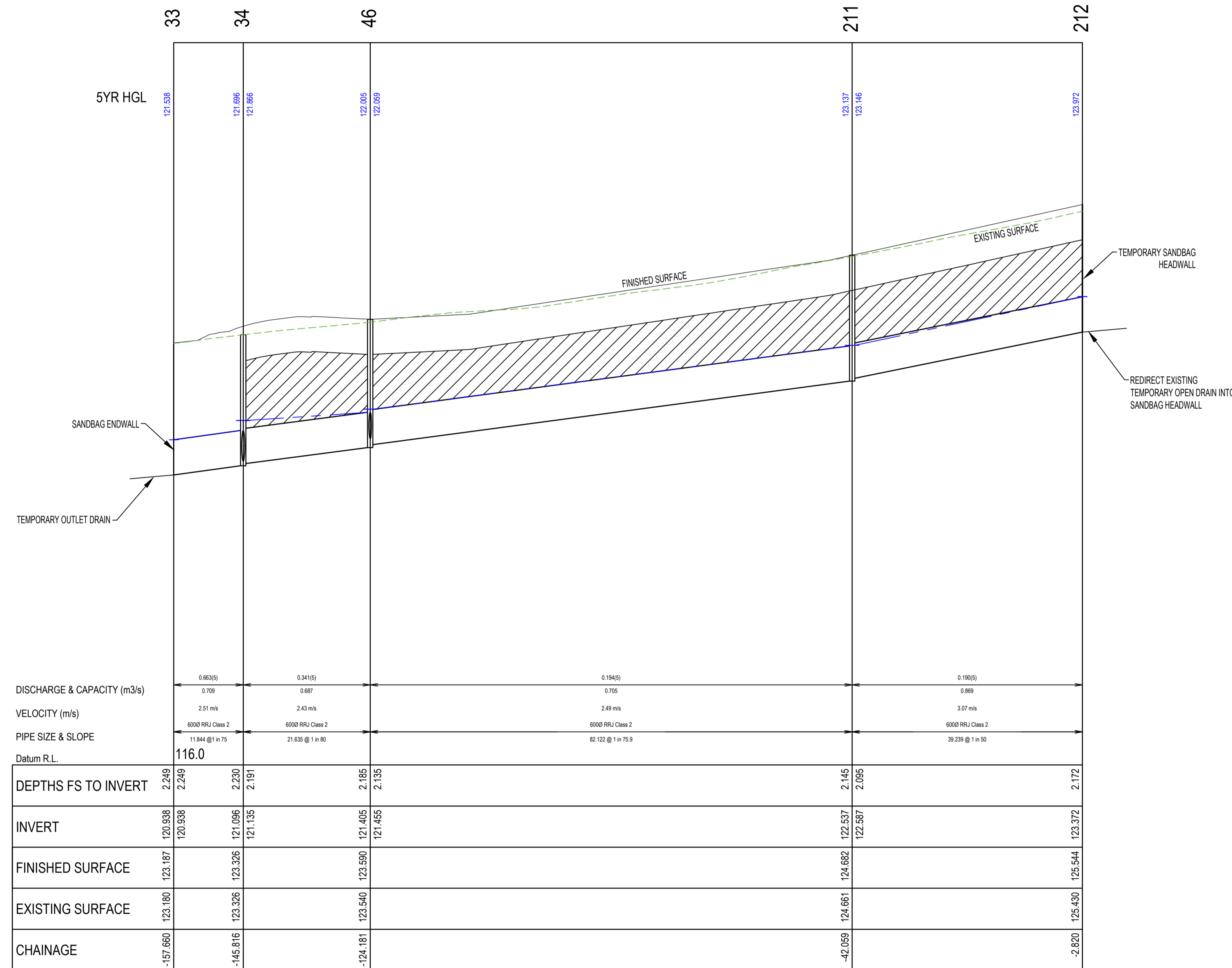

STRUCTURE SCHEDULE												
PIT No.	DESCRIPTION	INTERNAL DIMENSIONS		INLET		OUTLET		BRANCH CONNECTION		TOP OF PIT	DEPTH OF PIT	REMARKS
		L	W	DIA	LEVEL	DIA	LEVEL	DIA	LEVEL			
33	End of Pipe					600	120.938			123.187	2.249	Construct Temporary Outlet Drain to Daylight E: 299232.7650, N: 5824980.4641
34	Junction Pit	900	900	600	121.135	600	121.096	525	121.171	123.326	2.23	EDCM607 with Class B Cover. E: 299234.9397, N: 58224992.4747 / E: 299233.8993, N: 5824992.6163
46	Double Channel Grating Pit	900	900	600	121.455	600	121.405	450	121.555	123.59	2.185	EDCM602-EDCM607 with Class B Cover. E: 299236.9501, N: 5825013.2298 / E: 299237.0721, N: 5825014.1202
50	Junction Pit	600	900	300	121.921	450	121.771	300	121.995	123.677	1.907	EDCM605 with Class B Cover. E: 299230.5219, N: 5825024.5131 / E: 299230.6440, N: 5825025.4048
50A	Junction Pit	600	900	300	123.041	300	122.187			124.017	1.83	EDCM605 with Class B Cover. E: 299225.0657, N: 5825026.3163 / E: 299225.9573, N: 5825026.1941
94	Channel Grating Pit	600	900	300	122.997	300	122.947	124.716	1.769			EDCM601-EDCM605 with Class B Cover. E: 299240.2658, N: 5825095.6496 / E: 299240.3873, N: 5825096.5414
117	End of Pipe					300	123.247			124.988	1.741	E: 299241.7258, N: 5825108.5198
206	Double Channel Grating Pit	600	900	450	121.65	450	121.6			123.626	2.025	EDCM602-EDCM607 with Class B Cover. E: 299228.1231, N: 5825014.3016 / E: 299229.2146, N: 5825014.9693
207	Junction Pit	600	900	300	123.439	300	123.389			124.406	1.017	EDCM605 with Class B Cover. E: 299197.5210, N: 5825030.0657 / E: 299198.4135, N: 5825029.9434
208	Junction Pit	600	900	225	124.55	300	124.475			125.493	1.017	EDCM605 with Class B Cover. E: 299209.4320, N: 5825112.9662 / E: 299209.5541, N: 5825113.8579
209	End of Pipe			225	124.59	225	124.59			125.526	0.936	E: 299209.4648, N: 5825115.4335
211	Channel Grating Pit	900	900	600	122.587	600	122.537			124.682	2.145	EDCM601-EDCM605 with Class B Cover. E: 299246.0920, N: 5825094.5779 / E: 299248.2147, N: 5825095.4695
212	End of Pipe			600	123.372	600	123.372			125.544	2.172	E: 299253.6965, N: 5825133.2775
216	Channel Grating Pit	900	900	525	121.36	525	121.31			123.816	2.506	EDCM601-EDCM605 with Class B Cover. E: 299218.3735, N: 5824994.6795 / E: 299217.4817, N: 5824994.8008
217	Channel Grating Pit	900	900	525	121.474	525	121.424			123.823	2.399	EDCM601-EDCM605 with Class B Cover.
218	Junction Pit	900	900	525	121.863	525	121.813			124.147	2.334	EDCM607 with Class B Cover.
219	Channel Grating Pit	900	900	525	121.993	525	121.943			124.042	2.098	EDCM601-EDCM605 with Class B Cover.
220	Channel Grating Pit	900	900	450	122.128	525	122.053	300	122.373	124.042	1.989	EDCM601-EDCM605 with Class B Cover.
221	Junction Pit	600	900	375	122.546	450	122.471	375	122.674	124.401	1.929	EDCM605 with Class B Cover. E: 299158.1994, N: 5825035.7967 / E: 299158.3410, N: 5825036.8371
222	Channel Grating Pit	600	900	375	123.878	375	123.828	300	123.903	125.655	1.827	EDCM601-EDCM605 with Class B Cover. E: 299166.8151, N: 5825099.0880 / E: 299166.9365, N: 5825099.9798
222A	End of Pipe					375	123.926			125.706	1.784	E: 299169.9783, N: 5825124.3421
228	Channel Grating Pit	600	900	225	123.005	300	122.503	300	122.553	124.292	1.789	EDCM601-EDCM605 with Class B Cover.
229	Junction Pit	600	900			225	123.471			124.598	1.127	EDCM605 with Class B Cover. E: 299097.1166, N: 5825019.3102 / E: 299096.2248, N: 5825019.4316
230	Channel Grating Pit	600	900			300	122.638			124.283	1.646	EDCM601-EDCM605 with Class B Cover. E: 299145.8719, N: 5825004.5489 / E: 299144.9804, N: 5825004.6703
231	Channel Grating Pit	600	900			300	123.988			125.641	1.653	EDCM601-EDCM605 with Class B Cover. E: 299174.6429, N: 5825098.0224 / E: 299174.7643, N: 5825098.9142
234A	End of Pipe (Existing)					375	124.011			125.344	1.334	Remove Existing Headwall and Connect into Existing Drainage



- LEGEND:**
- EXISTING SURFACE PROFILE
  - FINISHED SURFACE PROFILE
  - INDICATES SYR HGL
  - ▨ INDICATES CRUSHED ROCK BACKFILL

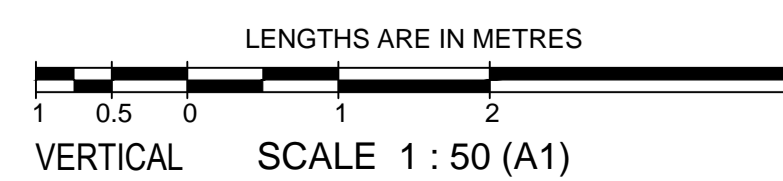
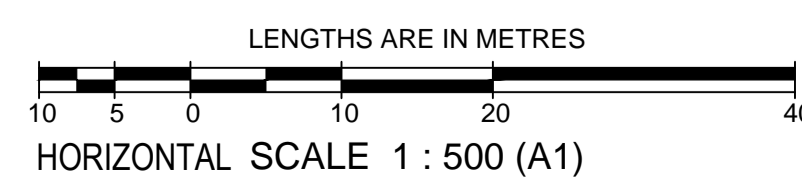

AMENDMENTS		 land surveyors civil engineers		1/19 cato street hawthorn east, 3123 telephone 8823 2300 fax no. 8823 2310	
VER	DATE	REMARKS	MELWAY REF. 354-C-12 SURVEY BPD DESIGN J.B DRAWN I.W CHECKED C. HAGEN	<b>ASPIRE ESTATE STAGE 27</b> DRAINAGE LONGITUDINAL SECTIONS - SHEET 3 DRAINAGE PIT DETAILS	
			SCALE AS SHOWN	DATUM AHD	DATE JULY '21
			SHEET 10 OF 14	P3	

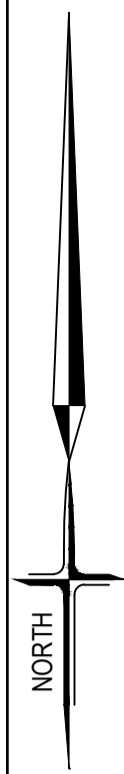

PLAN  
SCALE 1:500

  
**APPROVED**  
**DETAILED ENGINEERING PLANS**  
 Nihal Jayasekara  
 ENGINEERING SERVICES  
 Date: 26/11/2021

SIGNAGE LEGEND

- A

STREET SIGNS  
(S5-1)
- B

"GIVEWAY" SIGN  
(R1-2)
- C

"BI-DIRECTIONAL HAZARD MARKER" SIGN  
(R1-3)
- D

"CHEVRON" SIGN  
(D4-1-3 RIGHT)
- E

"CHEVRON" SIGN  
(D4-1-3 LEFT)
- F

"NO PARKING LEFT" SIGN  
(R5-35 LEFT)
- G

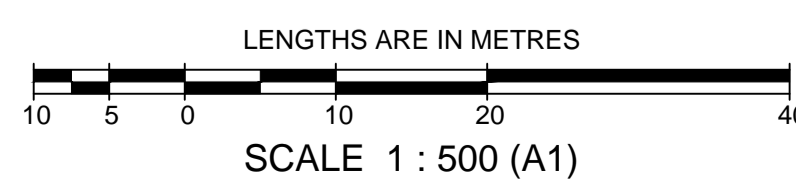

"NO PARKING RIGHT" SIGN  
(R5-35 RIGHT)

TYPICAL ISLAND  
CROSS  
SECTION (S13) AS PER  
CITY OF MELTON  
STANDARD DRAWING  
MCC 308

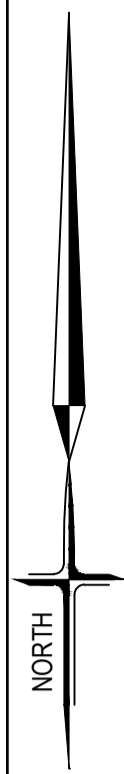

			 <b>breese pitt dixon pty. ltd.</b> land surveyors      civil engineers	1/19 cato street hawthorn east, 3123 telephone 8823 2300 fax no. 8823 2310
MELWAY REF.	354-C-12	ASPIRE ESTATE STAGE 27 SIGNAGE & LINEMARKING PLAN		MUNICIPALITY MELTON
SURVEY	BPD			REFERENCE 8226 E/27
DESIGN	J.B			
DRAWN	I.W			
CHECKED	C. HAGEN	SCALE	AS SHOWN	DATE
DATE		DATUM	AHD	JULY '21
REMARKS		SHEET	11 OF 14	P3



- LEGEND**
-  PROPOSED PASSIVE IRRIGATION TREE PITS
  -  EXISTING PASSIVE IRRIGATION TREE PITS

**NOTE:**  
LOCATION OF "TREENET" INLET TO BE COORDINATED WITH FINAL COUNCIL ENDORSED LANDSCAPE ARCHITECTS DRAWINGS.



**PLAN**  
SCALE 1:500

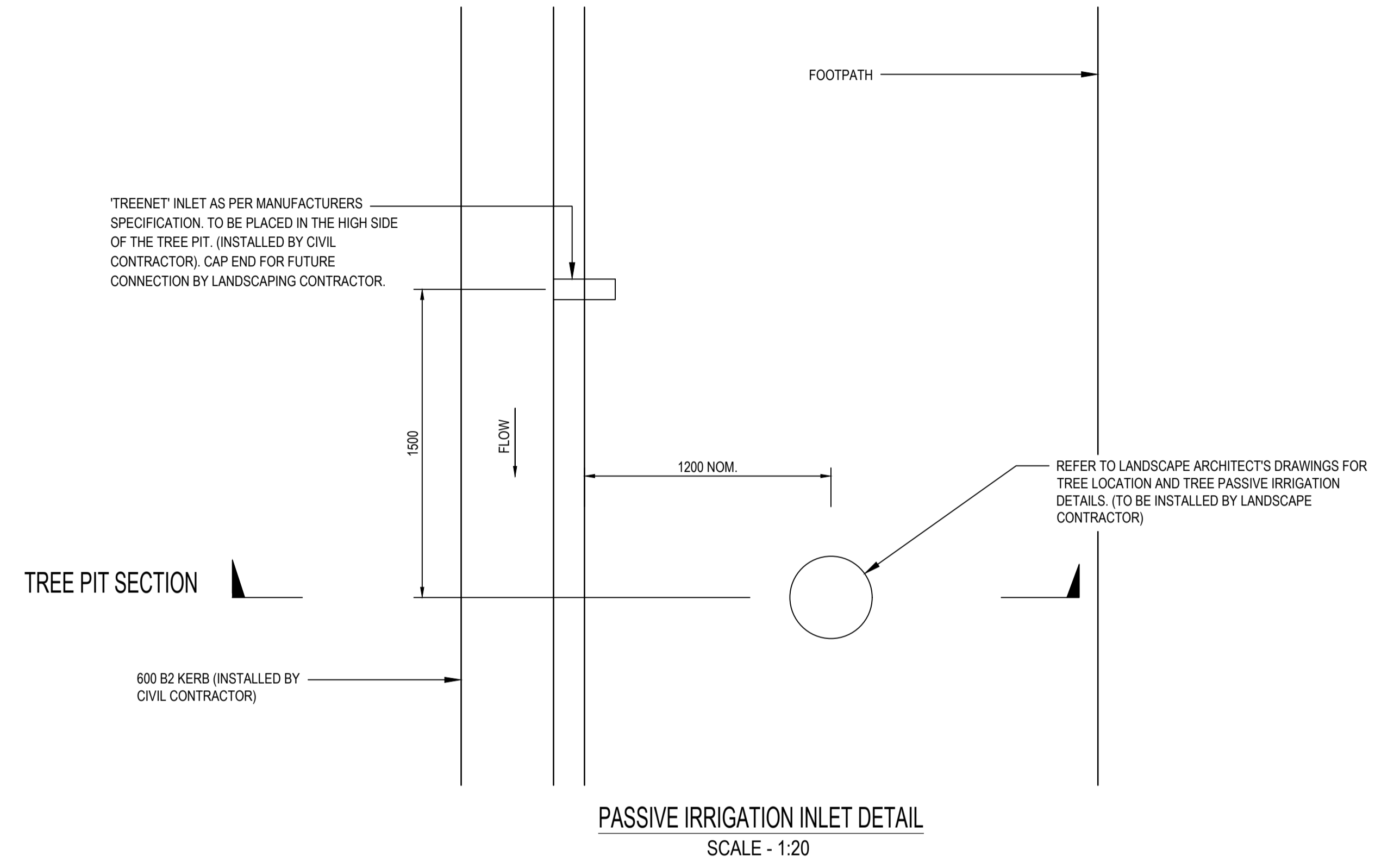

**TREE PIT SECTION**

**PASSIVE IRRIGATION INLET DETAIL**  
SCALE - 1:20

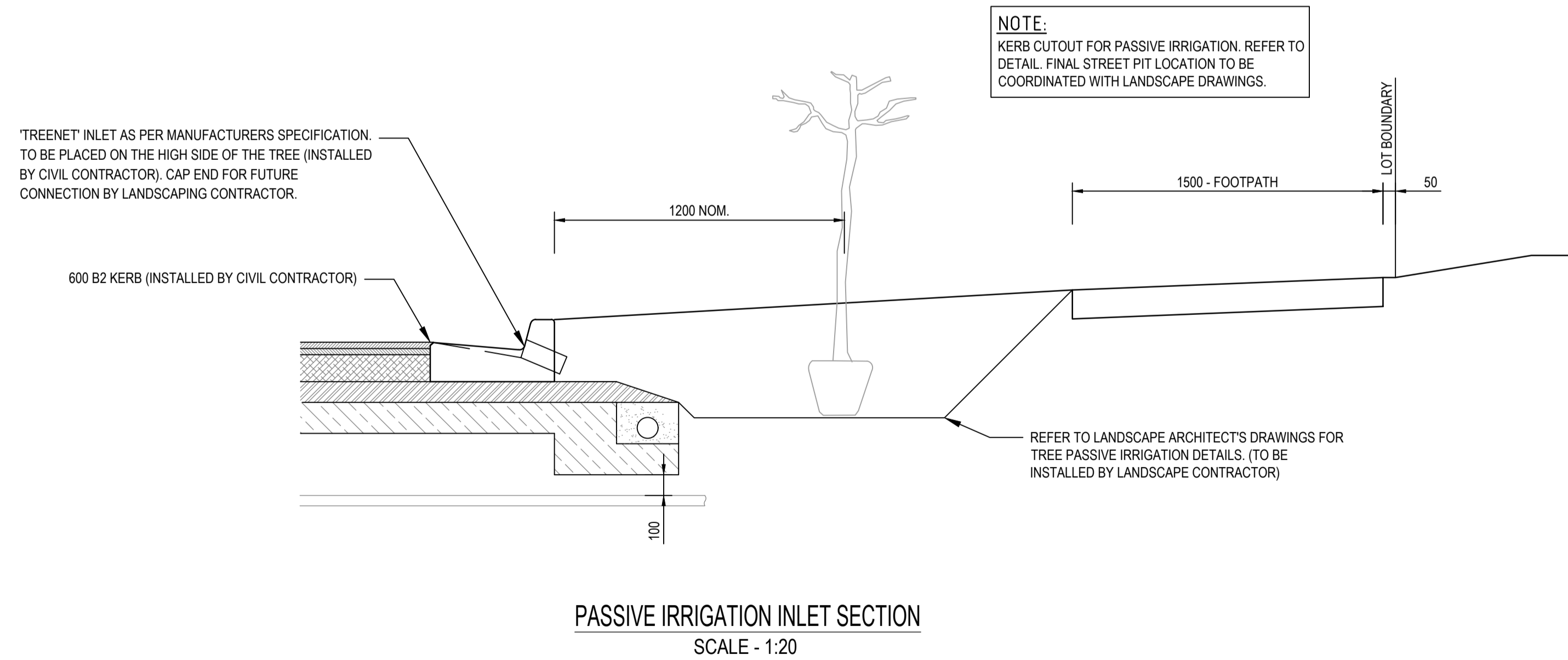

**PASSIVE IRRIGATION INLET SECTION**  
SCALE - 1:20

**MELTON**  
APPROVED  
DETAILED ENGINEERING PLANS  
Nihal Jayasekara  
ENGINEERING SERVICES  
Date: 26/11/2021

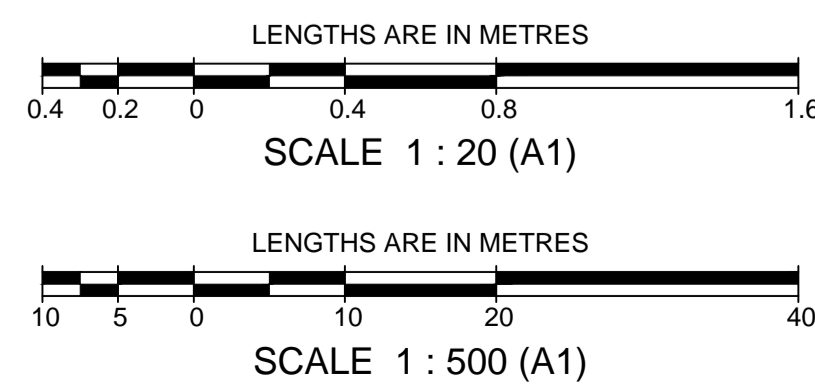

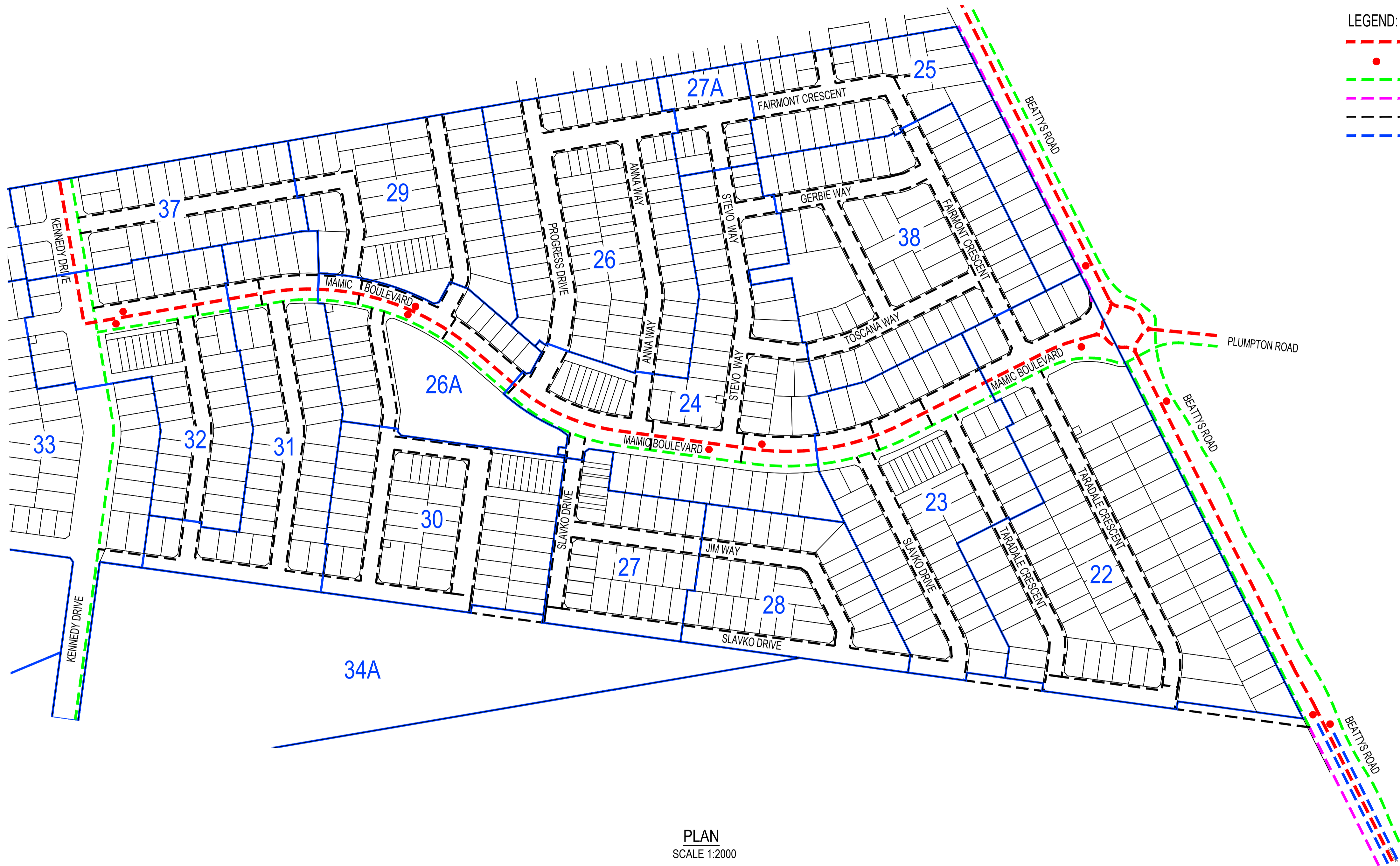
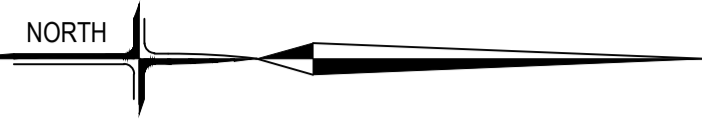

		 <b>breese pitt dixon pty. ltd.</b> land surveyors civil engineers		1/19 cato street hawthorn east, 3123 telephone 8823 2300 fax no. 8823 2310					
		MELWAY REF. 354-C-12	<b>ASPIRE ESTATE STAGE 27 PASSIVE IRRIGATION PLAN</b>		MUNICIPALITY <b>MELTON</b>				
		SURVEY BPD			REFERENCE 8226 E/27				
		DESIGN J.B							
		DRAWN I.W							
AMENDMENTS	VER	DATE	REMARKS	CHECKED C. HAGEN	SCALE AS SHOWN	DATUM AHD	DATE JULY '21	SHEET 12 OF 14	P3

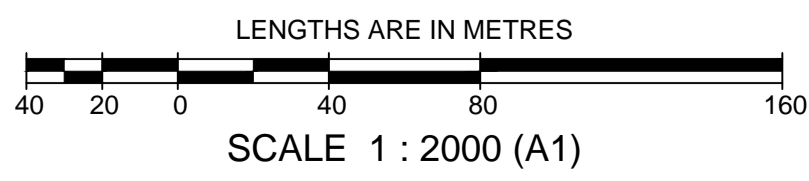

PLAN  
SCALE 1:2000

**CITY OF MELTON**  
 APPROVED  
 DETAILED ENGINEERING PLANS  
 Nihal Jayasekara  
 ENGINEERING SERVICES  
 Date: 26/11/2021



AMENDMENTS		 <b>breese pitt dixon pty. ltd.</b> land surveyors civil engineers 1/19 cato street hawthorn east, 3123 telephone 8823 2300 fax no. 8823 2310		MUNICIPALITY					
				MELTON					
				REFERENCE					
				8226 E/27					
VER	DATE	REMARKS	CHECKED	C. HAGEN	SCALE AS SHOWN	DATUM AHD	DATE JULY '21	SHEET 13 OF 14	P3

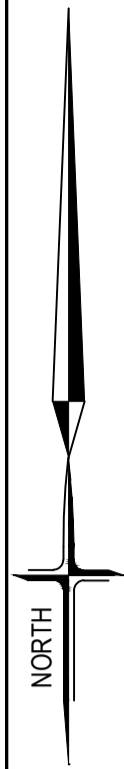

**MELTON**  
 APPROVED  
 DETAILED ENGINEERING PLANS  
 Nihal Jayasekara  
 ENGINEERING SERVICES  
 Date: 26/11/2021



**PLAN**  
SCALE 1:500

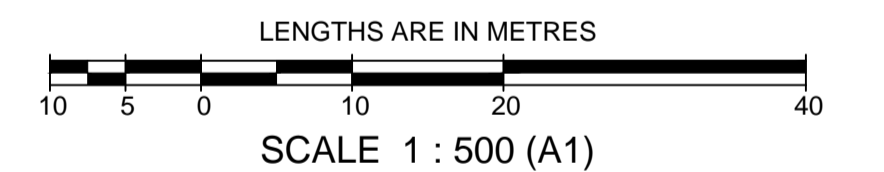

SYMBOL LEGEND			
Drains		Ex/Natural/FS Level	+28.57 +NS28.57 +FS28.57
Main Drains		FS @ Building Line	+BL28.57
Sewer < 3000		Top/Toe of Batter	+TOP28.57 +TOE28.57
Sewer ≥ 3000		Top Ret. Wall Level	+TW28.57
Water (DW)		100yr Flood Level	+FL28.57
Water (NDW)		Fill Proposed (<0.3m/≥0.3m)	
House Drain		Cut Proposed	
Property Inlet		Asphalt Surface Prop	
Street Sign		Concrete Surface Prop (Paths/Driveways/Slabs)	
FSM		Tree To Be Removed	
Rock Ret Wall		Tree To Be Retained with Tree Protection Zone (TPZ)	
Sleeper Ret Wall			
Conduits 50mm			
Conduits 100mm			
Street Tree without/with Passive Irrigation (Refer Detail)			
Ex Drains			
Ex Water DW/NDW			
Ex Sewer/Gas			
Ex Elect/Comm			
Ex Optic Fibre			

AMENDMENTS		 breese pitt dixon pty. ltd. land surveyors civil engineers	1/19 cato street hawthorn east, 3123 telephone 8823 2300 fax no. 8823 2310			
			MELWAY REF. 354-C-12	<b>ASPIRE ESTATE          STAGE 27          EARTHWORKS PLAN</b>		MUNICIPALITY MELTON
			SURVEY BPD			REFERENCE 8226 E/27
			DESIGN J.B			
DATE	REMARKS	CHECKED -	SCALE AS SHOWN DATUM AHD	DATE JULY '21	SHEET 14 OF 14	P3