





Refer to diagrams below for information regarding boundary fencing location requirements

-  = No fence allowed
-  = Colorbond fence in Woodlands Grey commencing at 1.2m and increasing to 1.8m high
-  = Colorbond fence in Woodlands Grey continuing at 1.8m high
-  = Fencing design to be submitted to Villawood Properties for approval

1. Fencing detail for side fence

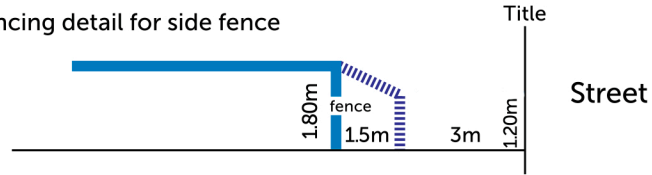

2. Fencing template for standard lot

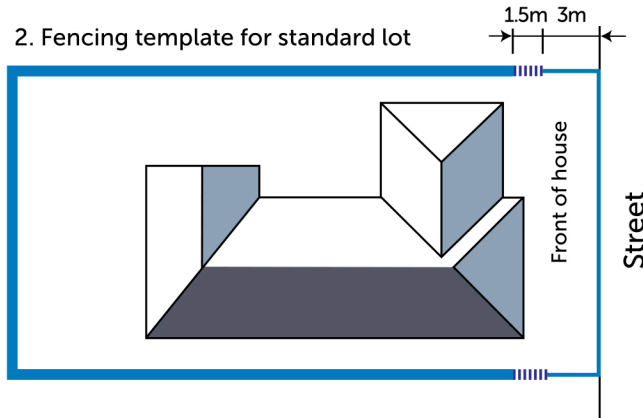

3. Fencing template for corner lot (a)

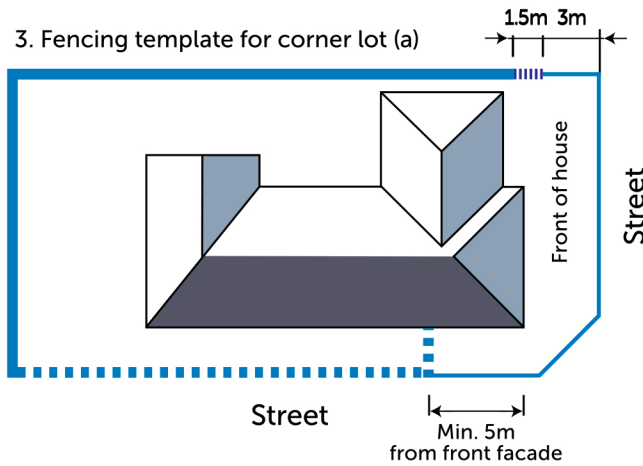

4. Fencing template for corner lot (b)

