

SHEET INDEX		
SHEET #	REVISION	DESCRIPTION
1	P1	OVERALL PLAN
2	P1	DETAIL PLAN - SHEET 1
3	P1	NOTES, PAVEMENT DETAILS & TYPICAL SECTIONS
4	P1	INTERSECTION DETAILS - SHEET 1
5	P1	GOLDRIDGE DRIVE LONGITUDINAL SECTION
6	P1	GOLDRIDGE DRIVE CROSS SECTIONS
7	P1	BLACKBUCK ROAD LONGITUDINAL SECTION
8	P1	BLACKBUCK ROAD CROSS SECTIONS
9	P1	RIVERBED DRIVE LONGITUDINAL SECTION
10	P1	RIVERBED DRIVE CROSS SECTIONS
11	P1	DRAINAGE LONGITUDINAL SECTIONS - SHEET 1
12	P1	DRAINAGE LONGITUDINAL SECTIONS - SHEET 2
13	P1	DRAINAGE PIT SCHEDULE
14	P1	SIGNAGE & LINEMARKING PLAN

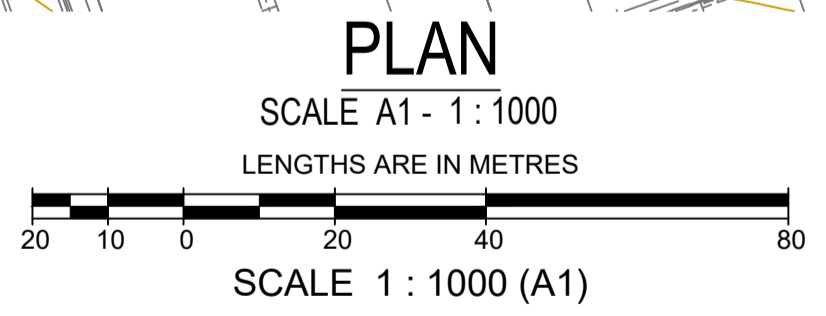

ATTENTION TO CONTRACTOR

- IT IS THE CONTRACTORS RESPONSIBILITY TO ENSURE THAT THE DIGITAL PLAN, PROVIDED FOR SETOUT PURPOSES, MATCHES THE TBM COORDINATES SHOWN.
- Contractor to ensure that the site is pegged and or set out checked by the licenced surveyor responsible for certifying the Plan of Subdivision prior to underground infrastructure being installed.
- Where concrete works about a sewer access chamber surround or similar structure, an expansion joint of approved material shall be provided between the two faces.

Location	Gas	Water		Communications		Electricity		BOK	Road Width	Joint Trenching	Street Classification
		NDW	DW	Cables	Pits	Cables	Poles				
RIVERBED DRIVE	2.10 E	2.60 E	3.10 E	5.80 W	1.80 E	6.60 W	1.00 BOK	4.35 E 8.05 W	20.00	G&W, FTTH&E	STREET LEVEL 1
GOLDRIDGE DRIVE	2.10 W	2.60 W	3.10 W	1.80 E	1.70 W	2.60 E	1.00 BOK	4.70 E 4.70 W	17.00	G&W, FTTH&E	STREET LEVEL 1
BLACKBUCK ROAD	2.10 N	3.10 N	2.60 N	1.80 S	1.70 N	2.60 S	1.00 BOK	4.20 N 4.20 S	16.00	G&W, FTTH&E	STREET LEVEL 1

NOTE: a) At the court bowl where water and gas mains pass, the watermain offset is to be increased by 0.5 metres.
b) * Indicates offsets from back of kerb where services do not run parallel to title boundary.
c) * Indicates Communication pits placed within concrete footpath.

breese pitt dixon pty. ltd. land surveyors civil engineers		1/19 cato street hawthorn east, 3123 telephone 8823 2300 fax no. 8823 2310	
MELWAY REF. - SURVEY B.P.D. DESIGN B.P.D. DRAWN M.T.		RATHDOWNE ESTATE STAGE 20 OVERALL PLAN	
CHECKED R.GOULD-WILLIAMS		SCALE AS SHOWN	DATUM AHD
DATE	REMARKS	DATE Aug 22	SHEET 1 OF 14 P1



PLAN

SCALE A1 - 1 : 500

LENGTHS ARE IN METRES



SCALE 1 : 500 (A1)

WARNING
BEWARE OF UNDERGROUND SERVICES
THE LOCATION OF UNDERGROUND SERVICES ARE APPROXIMATE ONLY AND THEIR EXACT POSITION SHOULD BE PROVEN ON SITE. NO GUARANTEE IS GIVEN THAT ALL EXISTING SERVICES ARE SHOWN.

SYMBOL LEGEND		
Drains	Prop	Ex/Natural/FS Level
Sewer < 3000	S	FS @ Building Line
Sewer ≥ 3000	S	Top/Toe of Batter
Water (DW)	W	Top Ret. Wall Level
Water (NDW)	W	100yr Flood Level
House Drain	H	Fill Proposed (<0.3m/±0.3m)
Property Inlet	I	Cut Proposed
Street Sign	Sign	Asphalt Surface Prop
Rock Ret Wall	R	Concrete Surface Prop
Sleeper Ret Wall	R	Concrete Surface Prop (Paths/Driveways/Slabs)
Conduits 50mm	GW	Tree To Be Removed
Conduits 100mm	W100	Tree To Be Retained with Tree Protection Zone (TPZ)
Street Tree without/with Passive Irrigation (Refer Detail)	Tree	
Ex Drains	Ex S	
Ex Water DW/NDW	Ex W	
Ex Sewer/Gas	Ex G	
Ex Elect/Comm	Ex E	

AMENDMENTS		breese pitt dixon pty. ltd.		1/19 cato street hawthorn east, 3123 telephone 8823 2300 fax no. 8823 2310	
		land surveyors		civil engineers	
MELWAY REF. -		RATHDOWNE ESTATE STAGE 20 DETAIL PLAN		MUNICIPALITY WHITTLESEA	
SURVEY B.P.D.				REFERENCE 9365 E/20	
DESIGN B.P.D.				SHEET 2 OF 14	
DRAWN M.T.		CHECKED R.GOULD-WILLIAMS	SCALE AS SHOWN	DATUM AHD	DATE Aug 22
VER	DATE	REMARKS			

NOTES:

- ALL WORKS TO BE CARRIED OUT IN ACCORDANCE WITH PLANS AND CURRENT CITY OF WHITTLESEA SPECIFICATIONS AND STANDARD DRAWINGS APPROVED BY COUNCIL AND TO THE SATISFACTION OF THE ENGINEER.
- COUNCIL TO BE NOTIFIED 2 CLEAR DAYS PRIOR TO COMMENCEMENT OF WORKS.
- DRAINAGE AND PITS TO BE SET OUT FROM OFFSETS SHOWN RATHER THAN FROM CENTRELINE PIPE CHAINAGES. REFER EDMCM01-608 FOR FURTHER DETAILS.
- ALL PIPES TO BE CLASS 2 UNLESS OTHERWISE SPECIFIED AND SHALL BE RRJ UP TO AND INCLUDING 75mm DIAMETER. PIPES ABOVE THIS SIZE MUST BE FLUSH JOINTED WITH EXTERNAL SEALING BANDS. ALL DRAINS THAT CROSS UNDER ROAD PAVEMENTS ARE TO BE CLASS 4 R.C.P.
- JOINING FOR CURVED PIPE ALIGNMENT SHALL CONFORM TO MANUFACTURER'S SPECIFICATIONS (RRJS FOR MINOR DEFLECTIONS OR COMPLETE R.C. BANDAGES)
- PROPERTY INLETS ARE TO BE PLACED 1.0m FROM THE LOW CORNER OF LOT UNLESS OTHERWISE SHOWN.
- LOTS DENOTED THUS 416H ARE TO BE PROVIDED WITH A 100mm HOUSE DRAIN PLACED 5.5m FROM THE LOW CORNER OF THE LOT UNLESS OTHERWISE SHOWN. HOUSE DRAINS TO BE CONNECTED TO STREET DRAINAGE WITH 27A & CAP. CLEAR OF ANY PAVING. IF CONNECTION IS WITHIN PAVING A PIT MUST BE USED.
- APPROVED GRANULAR BACKFILL TO BE PROVIDED WHERE PIPE TRENCHES ENROACH UNDER ROADWAY DUE TO DEEP EXCAVATIONS IN ROCK.
- SHALLOW CUT OFF DRAINS ARE TO BE PROVIDED ON SUBDIVISION BOUNDARY WHERE NECESSARY.
- PRIOR TO COMMENCEMENT OF WORKS ON SITE, THE CONTRACTOR MUST ENSURE THAT ALL MATTERS RELATING TO THE OCCUPATIONAL HEALTH AND SAFETY ACT 2004, INCLUDING ALL RELEVANT REGULATIONS, HAVE BEEN ADDRESSED. IN PARTICULAR, THE REQUIRED NOTIFICATIONS MUST BE CONVEYED TO THE VICTORIAN WORKCOVER AUTHORITY - HEALTH & SAFETY DIVISION WITH RESPECT TO TRENCHING OPERATIONS. DETAILS OF THE CONTRACTORS OCCUPATIONAL HEALTH & SAFETY PROCEDURES MUST BE LODGED WITH THE SUPERINTENDENT PRIOR TO COMMENCEMENT OF WORKS.
- AGRICULTURAL PIPE DRAINS TO BE PLACED BEHIND ALL KERB AND CHANNEL AND BUFFER PITCHERS AND WHERE DIRECTED BY THE ENGINEER (REFER TO STD DRG EDMCM20).
- ALL DRAINAGE TRENCHES UNDER ROAD PAVEMENTS, KERB & CHANNEL, PARKING BAYS, DRIVEWAYS, FOOTPATHS AND BEHIND KERB & CHANNEL SHALL BE BACKFILLED WITH CRUSHED ROCK
- BATTERS SHALL BE 1 IN 6 FOR CUT & FILL UNLESS OTHERWISE SHOWN. BATTERS EXCEEDING 1 IN 6 MUST BE STABILISED AS PER COUNCIL REQUIREMENTS.
- ALL NATIVE TREES AND SHRUBS TO BE RETAINED UNLESS ROAD CONSTRUCTION NECESSITATES THEIR REMOVAL OR REMOVAL IS DIRECTED BY THE ENGINEER.
- LOTS TO BE GRADED AND LEFT CLEAN TO THE SATISFACTION OF THE ENGINEER.
- ON COMPLETION THE CONTRACTOR IS RESPONSIBLE FOR THE REMOVAL OF RUBBISH AND SPOIL FROM SITE.
- WHERE WORKS ARE IN THE VICINITY OF EXISTING SERVICES, THESE SERVICES ARE TO BE LOCATED AND THE VARIOUS AUTHORITIES NOTIFIED PRIOR TO COMMENCEMENT OF WORKS.
- ALL MATERIAL SURROUNDING SERVICE AUTHORITY PITS LOCATED IN FOOTPATHS MUST BE ADEQUATELY COMPACTED IN 150mm LAYERS AND TESTED TO THE SATISFACTION OF THE CITY OF WHITTLESEA PRIOR TO THE CONSTRUCTION OF FOOTPATH BAYS ADJACENT TO THESE PITS.
- THE WATER CONDUIT OFFSET FROM THE LOT BOUNDARY IS GIVEN ON THE WATER RETICULATION PLAN. THE CONTRACTOR MUST CONSTRUCT CONDUITS TO ACCORD WITH THE GIVEN OFFSET AND ENSURE THAT THE CONCRETE MARKS THE KERB AND FOOTPATH EXACTLY ABOVE THE CONDUIT.
- ALL GAS AND WATER CONDUITS FOR RESIDENTIAL LOTS TO BE PVC CLASS 12, 50mm DIAMETER & 100mm DIAMETER RESPECTIVELY.
- TELSTRAINBN Co TO BE NOTIFIED 7 DAYS PRIOR TO CONCRETE BEING PLACED.
- CONDUITS ARE TO BE EXTENDED 450mm BEHIND FACE OF KERB AND TO BE REFERENCED ON FACE OF KERB.
- ALL STREET SIGNS TO BE CONSTRUCTED AND ERECTED TO CURRENT CITY OF WHITTLESEA STANDARDS. STREET NAME PLATES TO BE IN ACCORDANCE WITH STANDARD DRAWING SD625, INCLUDING "NO THROUGH ROAD" NOMINATION WHERE APPLICABLE.
- TRAFFIC CONTROL SIGNS, MARKINGS & DELINEATORS TO BE INSTALLED IN ACCORDANCE WITH AS1742.2. ALL LINE MARKING IS TO BE LONG LIFE ROAD MARKING, WITH LONGITUDINAL LINES IN THERMOPLASTIC & TRANSVERSE MARKINGS IN COLD APPLIED.
- ALL DRIVEWAYS ARE TO BE CONSTRUCTED IN ACCORDANCE WITH EDMCM501 & 502 AND ARE TO BE OFFSET 0.75m FROM SIDE BOUNDARY OR EASEMENT UNLESS OTHERWISE SHOWN.
- ALL DRIVEWAY RAMPS INTO PROPERTIES ARE TO BE CUT IN AT A MAXIMUM GRADE OF 1 IN 6.
- ALL PEDESTRIAN CROSSINGS ARE TO BE CONSTRUCTED GENERALLY IN ACCORDANCE WITH EDMCM03. ALL PRAM CROSSING SPLAYS MUST BE 600mm WIDE AND NO GREATER.
- FILL AREAS ARE TO BE STRIPPED OF TOPSOIL, FILLED AND TOPSOIL REPLACED TO OBTAIN FINAL FILL LEVELS AS SHOWN ON PLANS. FILLING TO BE CLEAN CLAY COMPACTED TO A DRY DENSITY NOT LESS THAN 95% OF THE MAXIMUM DRY DENSITY VALUE DETERMINED BY THE STANDARD COMPACTION TEST IN ACCORDANCE WITH AUSTRALIAN STANDARD AS1289.5.2.1-2003. CONTROL TESTING TO COMPLY WITH AS3798-2007 APPENDIX B, LEVEL 1.
- THE CONTRACTOR IS RESPONSIBLE FOR ENSURING THAT ALL IMPORTED FILL MATERIAL, INCLUDING TOPSOIL, SATISFIES THE DESCRIPTION FOR CLEAN FILL MATERIAL IN EPA BULLETIN PUBLICATION No. 448 (SEPT '95) AND SUBSEQUENT REVISIONS. THE CONTRACTOR SHALL PROVIDE VERIFICATION INCLUDING TEST CERTIFICATES TO THE SUPERVISING ENGINEER.
- FILL REQUIRED UNDER ROADWAY KERB AND CHANNEL AND FOOTPATH TO BE UNDERTAKEN AS PER COUNCIL'S CONSTRUCTION SPECIFICATION FOR ROAD & DRAINAGE WORKS 20.6 (TYPE A MATERIAL AS PER VICROADS STANDARD SPECIFICATION 204) AND COMPACTED TO 98% AASHO IN 150mm LAYERS.
- PAVEMENT DEPTH MAY NOT BE ALTERED WITHOUT WRITTEN APPROVAL FROM CITY OF WHITTLESEA DEVELOPMENT ENGINEERING UNIT PRIOR TO THE COMMENCEMENT OF WORKS. ADDITIONAL COSTS WILL NOT BE CONSIDERED POST TENDER.
- THE CONTRACTOR IS TO ORGANISE AND PAY FOR TESTING OF PAVEMENT BASE COURSE MATERIAL AND FINAL LAYER OF CRUSHED ROCK. A COPY OF RESULTS IS TO BE FORWARDED TO THE DIRECTOR OF ENGINEERING OR HIS REPRESENTATIVE. THE RESULTS MUST MEET THE REQUIREMENTS OF THE CITY OF WHITTLESEA SPECIFICATION BEFORE ANY FURTHER WORKS ARE REQUIRED.
- THE CONTRACTOR MUST COMPLETE A LEVEL CHECK BETWEEN ALL TBM'S TO VERIFY LEVEL VALUES BEFORE COMMENCEMENT OF WORKS. ALL TBM'S AND CONTROL POINTS ARE TO BE MAINTAINED AND PROTECTED AT ALL TIMES DURING CONSTRUCTION. SHOULD ANY MARKS BE DISTURBED, THE CONTRACTOR WILL IMMEDIATELY NOTIFY THE DEVELOPER'S CONSULTANT TO ARRANGE RE-INSTALLATION AT THE CONTRACTORS EXPENSE.

- PRIOR TO COMMENCEMENT OF WORKS, THE CONTRACTOR MUST SUBMIT A SMP TO THE DEVELOPER'S CONSULTANT FOR APPROVAL. THE CONTRACTOR MUST COMPLY WITH THE RECOMMENDATIONS OF THE ENVIRONMENT PROTECTION AUTHORITY PUBLICATION No.275 "CONSTRUCTION TECHNIQUES FOR SEDIMENT POLLUTION CONTROL" AND MW SITE ENVIRONMENTAL MANAGEMENT POLICY 3.8.2. APPROPRIATE SILTATION CONTROL IS TO BE MAINTAINED THROUGHOUT THE CONSTRUCTION AND MAINTENANCE PERIOD OF THE WORKS. THE SMP SHALL BE APPROVED BY CITY OF WHITTLESEA DEVELOPMENT ENGINEERING UNIT PRIOR TO THE COMMENCEMENT OF WORKS.
- ALL FOOTPATHS IN ROADS TO BE OFFSET 50mm FROM PROPERTY BOUNDARY. FOOTPATHS CONSTRUCTED ABOVE EXISTING LEVEL TO BE CONSTRUCTED ON APPROVED FILL (TO AS-3798) OF F.C.R. INTO NATURAL GROUND.
- PRIOR TO COMMENCEMENT OF WORKS TREE PROTECTION ZONES (TPZ) ARE TO BE INSTALLED AS SPECIFIED IN THE ANNOTATED DETAILS FORMING PART OF THE PLANNING PERMIT TO TREES NOTED "TO BE RETAINED". THIS INCLUDES THE FOLLOWING:
 - RING LOCK WIRE MESH MINIMUM 1.20m HIGH (STD DRG SDL2.02)
 - MAIN POSTS 100mm TREATED PINE (TP), MINIMUM 1.80m HIGH
 - INTERMEDIATE POSTS STEEL STAR PICKETS (SP), MINIMUM 1.80m HIGH
 - THE CORNER POSTS ARE TO BE TP WITH TP STAYS
 - EVERY THIRD POST TO BE TP
 - SP TO BE PLACED INTERMEDIATELY BETWEEN THE TP AT MAX 3.0m INTERVALS
 - THE RING LOCK MESH TO ENCIRCLE THE STRUCTURE AND BE FIRMLY SECURED AT EACH POST
 - POSTS MUST BE SUNK INTO THE GROUND BY 450mm (THERE IS TO BE NO CONCRETE TO SECURE POSTS AS THIS WILL AFFECT pH LEVELS)
 - HIGH VISIBILITY HAZARD MARKER TAPE SECURELY FIXED TO TOP OF WIRE MESH FENCE WITH WIRE TIES
 - THE TREE PROTECTION ZONE IS TO BE CLEARLY SIGN POSTED IN ACCORDANCE WITH CONDITION 20 OF THE PLANNING PERMIT (STD DRG SDL2.03)

NO EXCAVATION SHALL BE CARRIED OUT WITHIN 5.0m OF ANY TREE UNTIL APPROVAL IS GIVEN BY THE ENGINEER.

37. PROVIDE 1.8m HIGH PALING FENCE ALONG ANY COMMON BOUNDARY BETWEEN A LOT AND MUNICIPAL RESERVE. FENCING TO BE ERECTED BY THE DEVELOPER (OR OWNER) AT NO COST TO COUNCIL. PALINGS TO BE ON THE RESERVE SIDE AND CONSTRUCTED IN ACCORDANCE WITH COUNCIL STANDARD DRAWING SDL.3.09 & SDL.3.10.

38. VEHICULAR EXCLUSION FENCING TO BE PROVIDED ALONG THE ROAD FRONTAGES OF ALL RESERVES. REFER LANDSCAPE PLANS FOR FENCE DETAILS. FENCING TO BE CONSTRUCTED AS PART OF LANDSCAPE WORKS.

39. PROVIDE TEMPORARY SAFETY BARRIER FENCE (FARM FENCE AS PER MW STD. DWG. 7251/8/203) ALONG EDGE OF OUTFALL DRAINS. SAFETY FENCE TO REMAIN UNTIL PERMANENT UNDERGROUND DRAINAGE IS INSTALLED.

40. EXISTING DAM OR WATERCOURSES TO BE EXCAVATED TO A FIRM BASE AND BACKFILLED AS SPECIFIED. DEVELOPER'S CONSULTANT TO BE NOTIFIED WHEN THE DAM OR WATERCOURSES ARE EXCAVATED TO A FIRM BASE. NO FILLING IS TO BE PLACED PRIOR TO DAMS BEING INSPECTED AND LEVELS TAKEN. BACKFILLING IS TO BE CARRIED OUT TO THE SATISFACTION OF THE COUNCIL SUPERVISING ENGINEER.

41. TACTILE GROUND SURFACE INDICATORS (TGSIs) ARE TO BE INSTALLED WHERE SHOWN IN ACCORDANCE WITH COUNCIL STD DRG SD320 AND AS1428.

42. A BUILDING PERMIT MUST BE OBTAINED FOR ANY STRUCTURAL/RETAINING WALL EXCEEDING 1.0m IN HEIGHT PRIOR TO THE COMMENCEMENT OF CONSTRUCTION IN ACCORDANCE WITH THE BUILDING CODE OF AUSTRALIA. A COPY OF BUILDING PERMITS AND CERTIFICATE OF COMPLIANCE - CONSTRUCTION TO BE SUBMITTED TO COUNCIL PRIOR TO STATEMENT OF COMPLIANCE.

43. ALL STRUCTURAL WORKS MUST BE SUPERVISED BY A QUALIFIED STRUCTURAL ENGINEER.

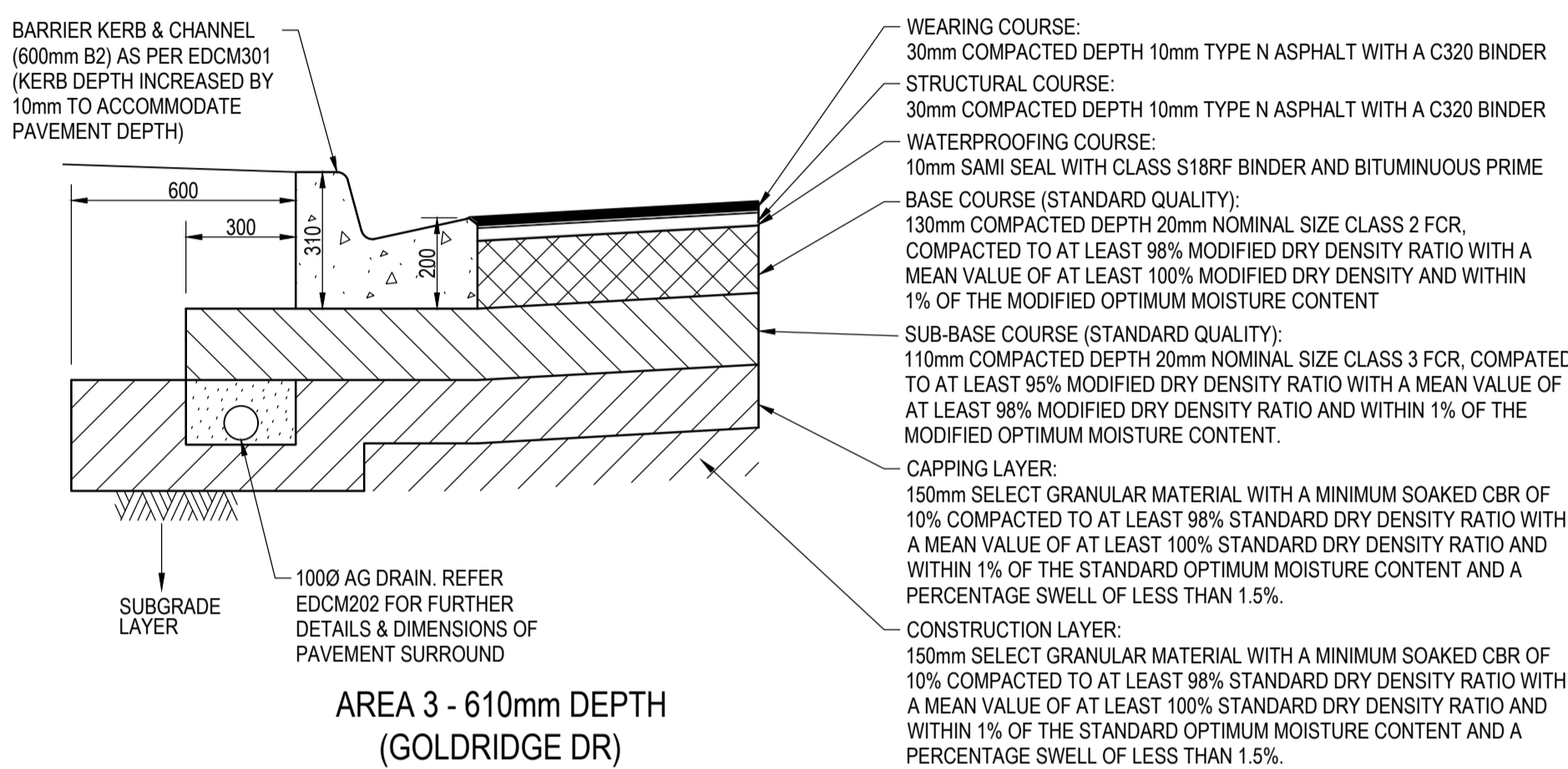
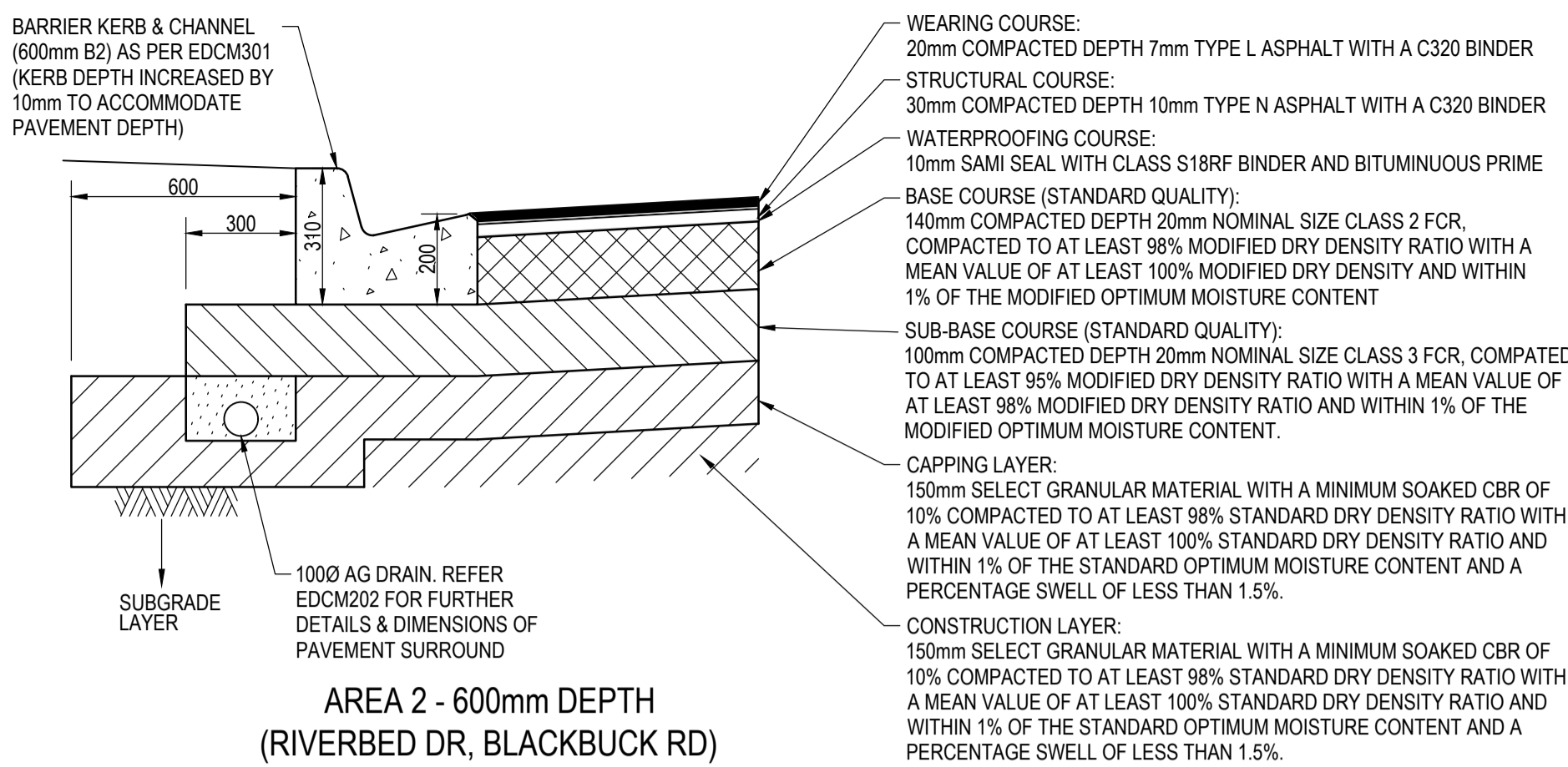

PAVEMENT COMPOSITION
SCALE A1 - N.T.S
REFER TO MIRCSD 02 Q7 FOR FURTHER AG, SERVICE CONDUIT AND TRENCH BACKFILL DETAILS

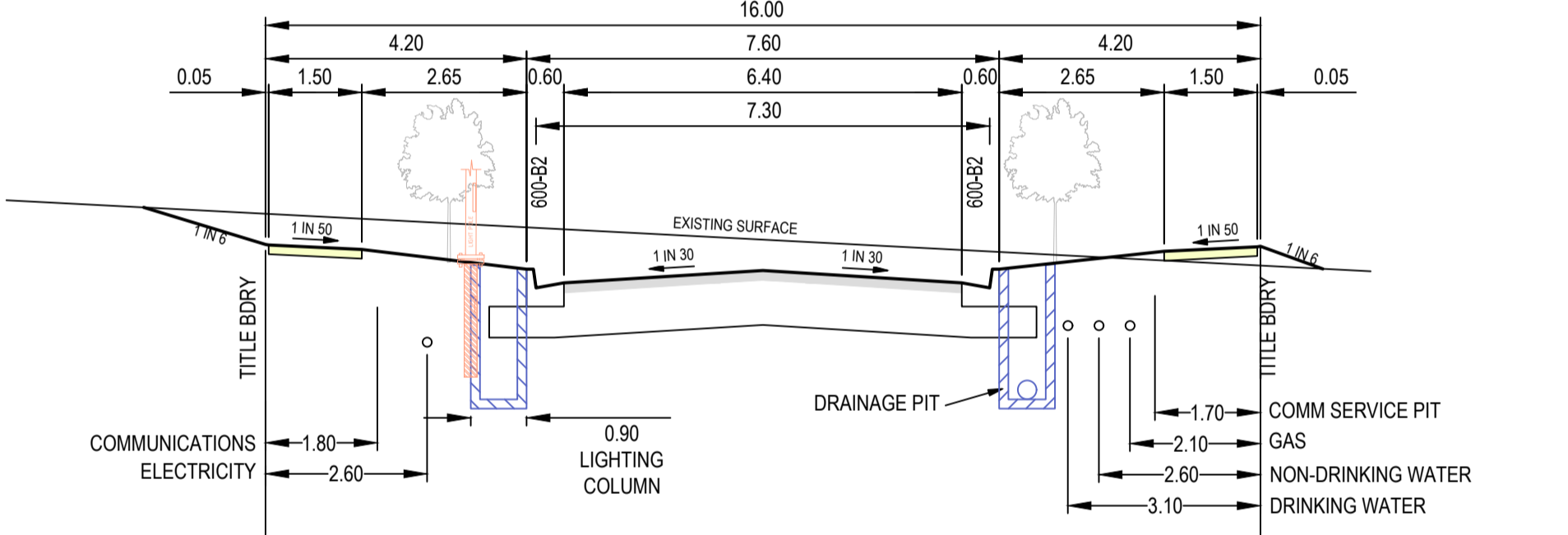
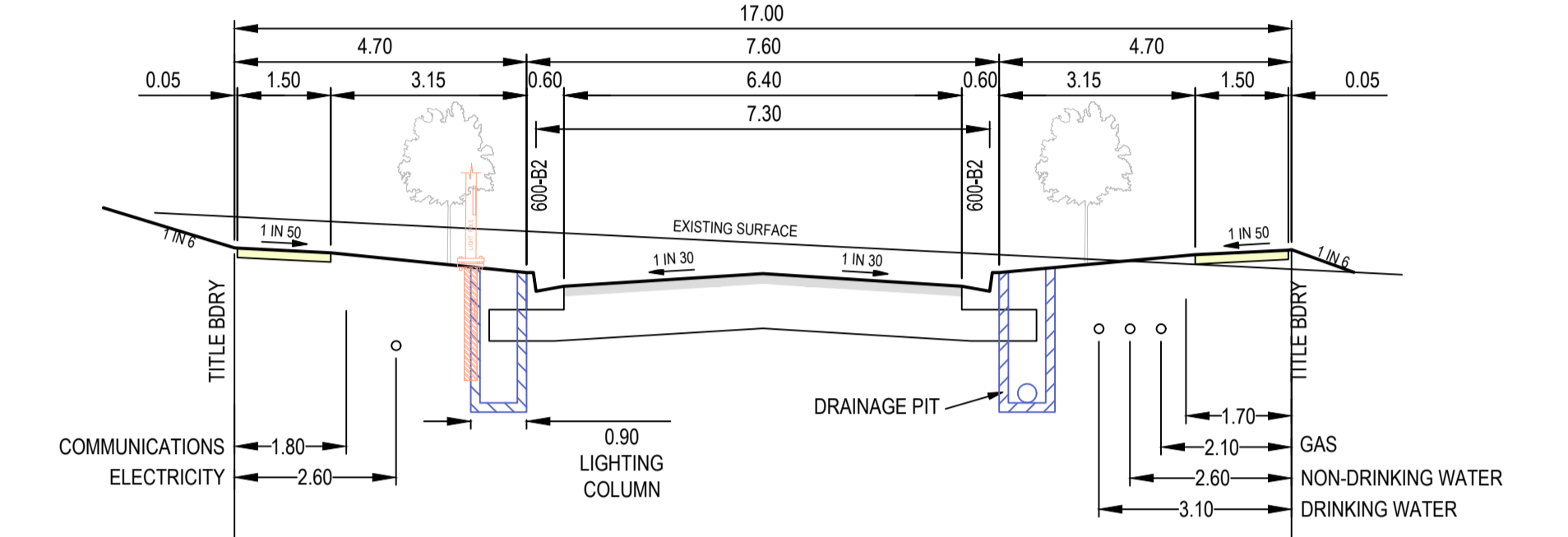
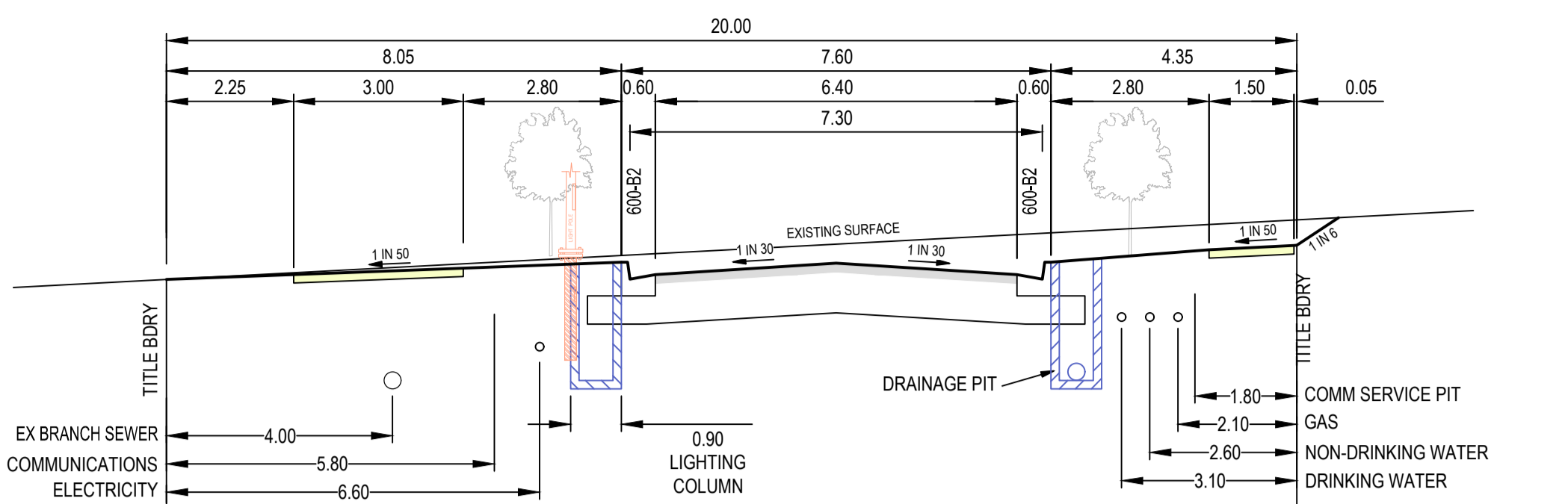
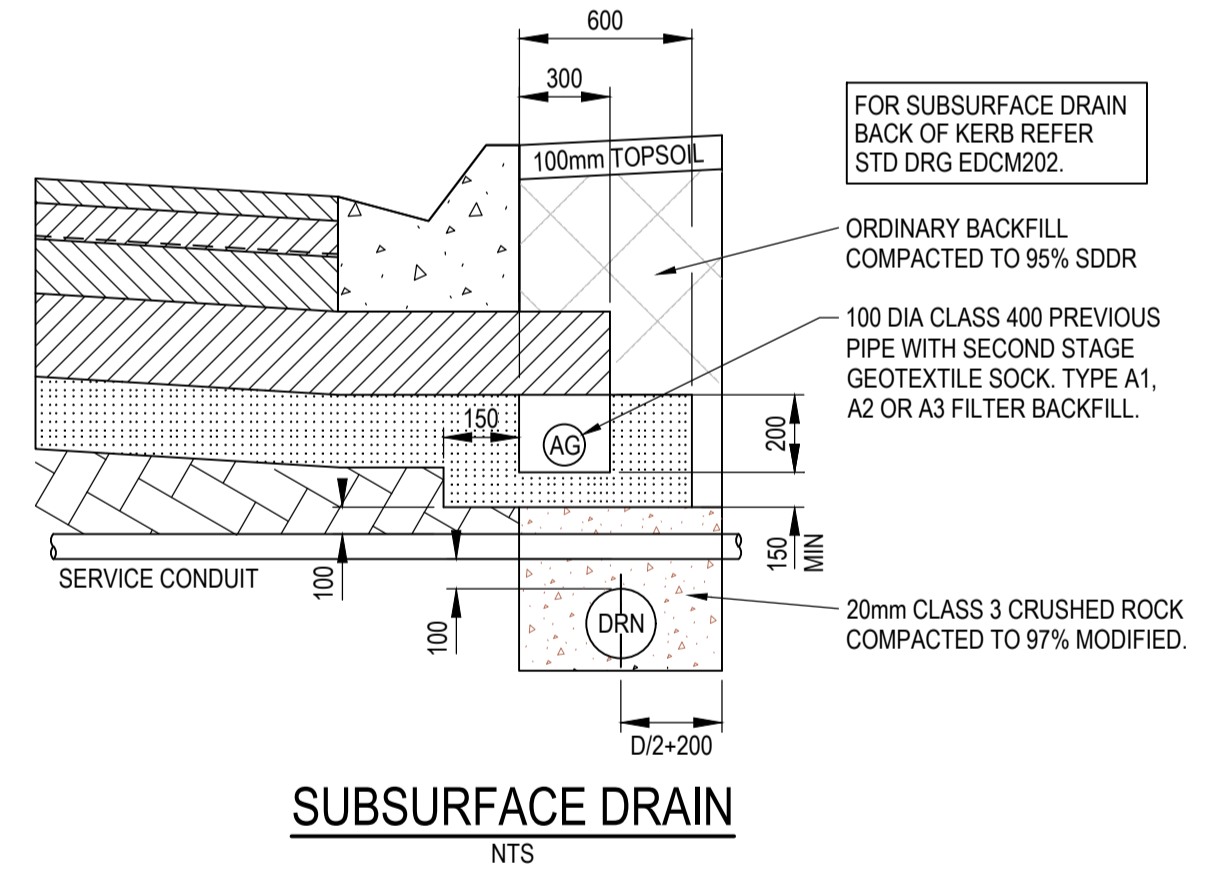

TYPICAL ROAD CROSS SECTIONS

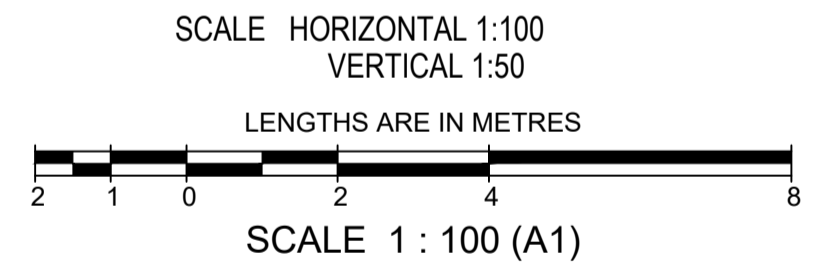

AMENDMENTS		<p>breese pitt dixon pty. ltd. land surveyors civil engineers</p> <p>1/19 cato street hawthorn east, 3123 telephone 8823 2300 fax no. 8823 2310</p>	<p>MELWAY REF. -</p> <p>SURVEY B.P.D.</p> <p>DESIGN B.P.D.</p> <p>DRAWN M.T.</p> <p>CHECKED R.GOULD-WILLIAMS</p>		<p>RATHDOWNE ESTATE STAGE 20</p> <p>NOTES, PAVEMENT DETAILS & TYPICAL SECTIONS</p> <p>SCALE AS SHOWN DATUM AHD DATE Aug 22</p>		<p>MUNICIPALITY WHITTLESEA</p> <p>REFERENCE 9365 E/20</p> <p>SHEET 3 OF 14 <i>P1</i></p>	
VER	DATE		REMARKS	SCALE	DATUM	AHD	DATE	SHEET

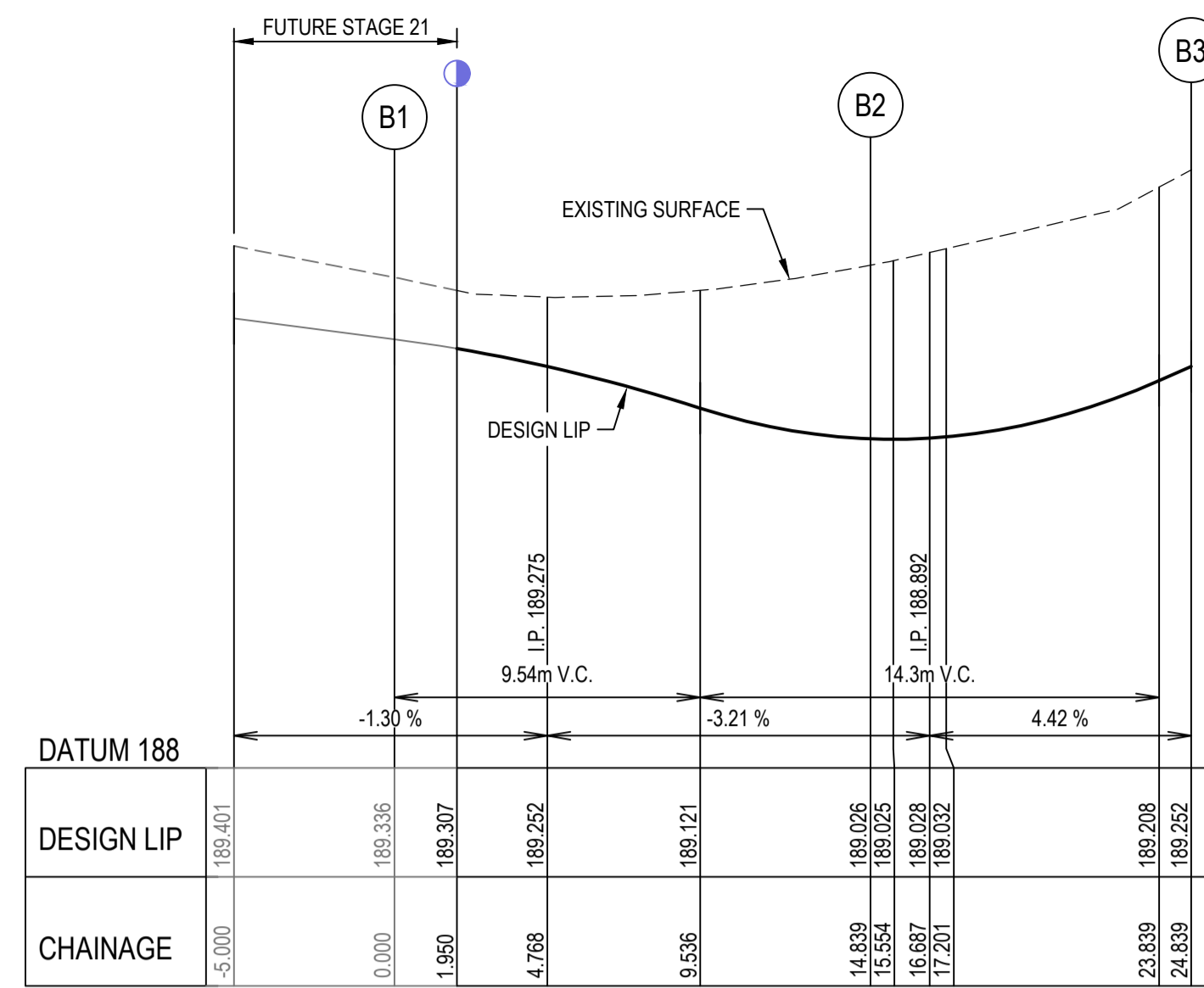
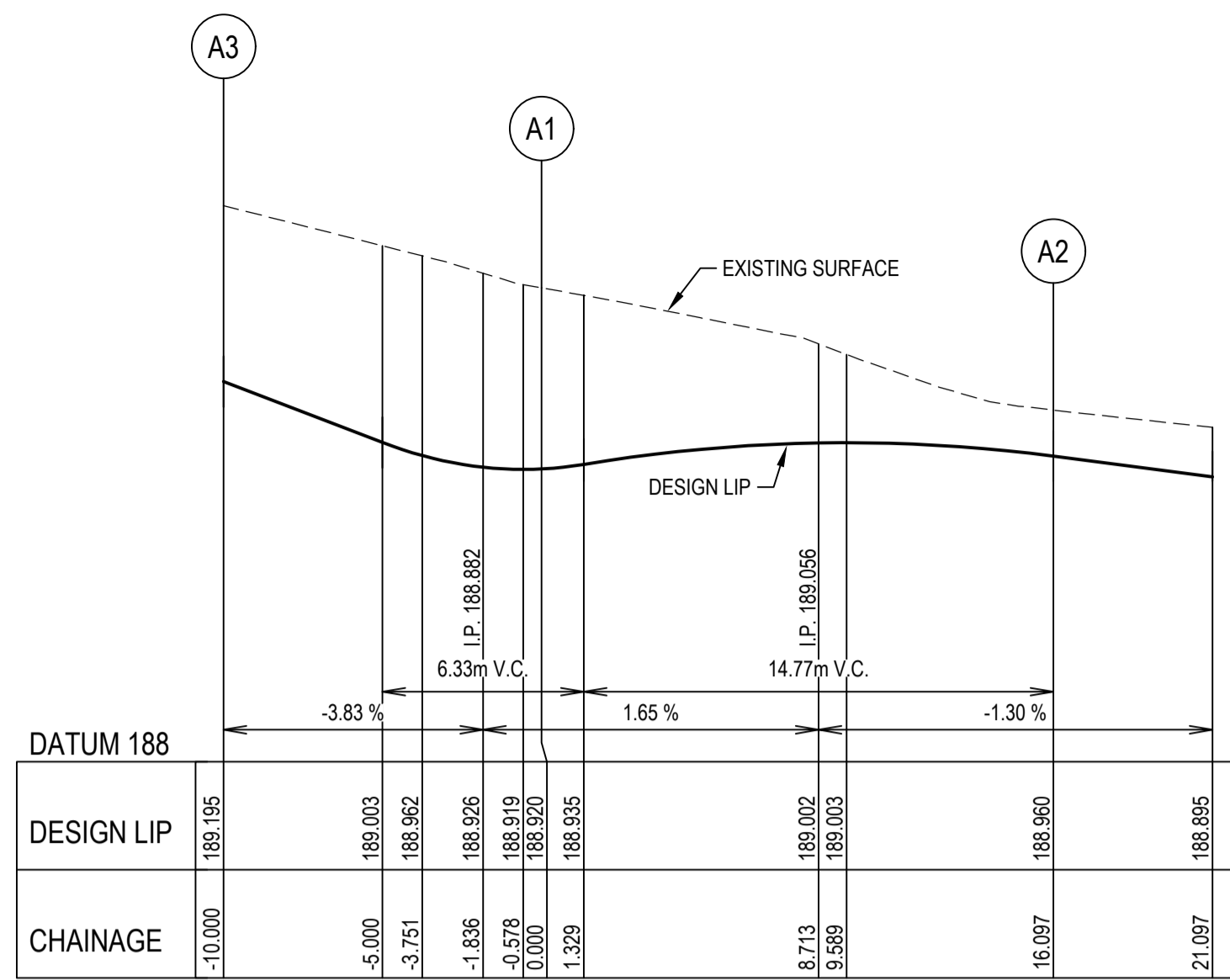

SETOUT TABLE				LIP LINE A						
PT No.	EAST.	NORTH.	LEVEL	TAG	CHAINAGE	EASTING	NORTHING	LENGTH	RADIUS	A.Length
A1	322028.75	5837560.66	188.920	L1	IP	-10.000	322038.653	5837559.353	6.249	-
A2	322018.22	5837551.67	188.960	L1	TP	-3.751	322032.441	5837560.031	-	-
A3	322038.65	5837559.35	189.195	C1	TP	-1.873	322030.574	5837560.235	3.751	31.2
A4	322024.76	5837560.64	188.972	C1	TP	0.000	322028.746	5837560.662	-	-
A5	322021.21	5837558.83	189.000	C2	TP	0.000	322028.746	5837560.662	-	-
A6	322018.86	5837555.60	188.997	C2	IP	11.673	322017.377	5837563.312	16.097	8.6
				C2	TP	16.097	322018.215	5837551.668	-	-
				L2	IP	16.097	322018.215	5837551.668	5.000	-
				L2	TP	21.097	322018.575	5837546.681	-	-

SETOUT TABLE				LIP LINE B						
PT No.	EAST.	NORTH.	LEVEL	TAG	CHAINAGE	EASTING	NORTHING	LENGTH	RADIUS	A.Length
B1	322024.49	5837578.20	189.336	L3	IP	-5.000	322026.248	5837582.884	5.000	-
B2	322030.80	5837566.76	189.026	L3	TP	0.000	322024.493	5837578.202	-	-
B3	322040.73	5837565.56	189.252	C3	TP	10.045	322020.967	5837568.797	14.839	8.6
B4	322023.97	5837574.56	189.275	C3	TP	14.839	322030.803	5837566.761	-	-
B5	322025.02	5837571.03	189.184	C4	TP	14.839	322030.803	5837566.761	2.362	24.8
B6	322027.44	5837568.26	189.081	C4	IP	16.021	322031.961	5837566.522	2.362	24.8
				C4	TP	17.201	322033.136	5837566.394	-	-
				L4	IP	17.201	322033.136	5837566.394	7.638	-
				L4	TP	24.839	322040.729	5837565.564	-	-

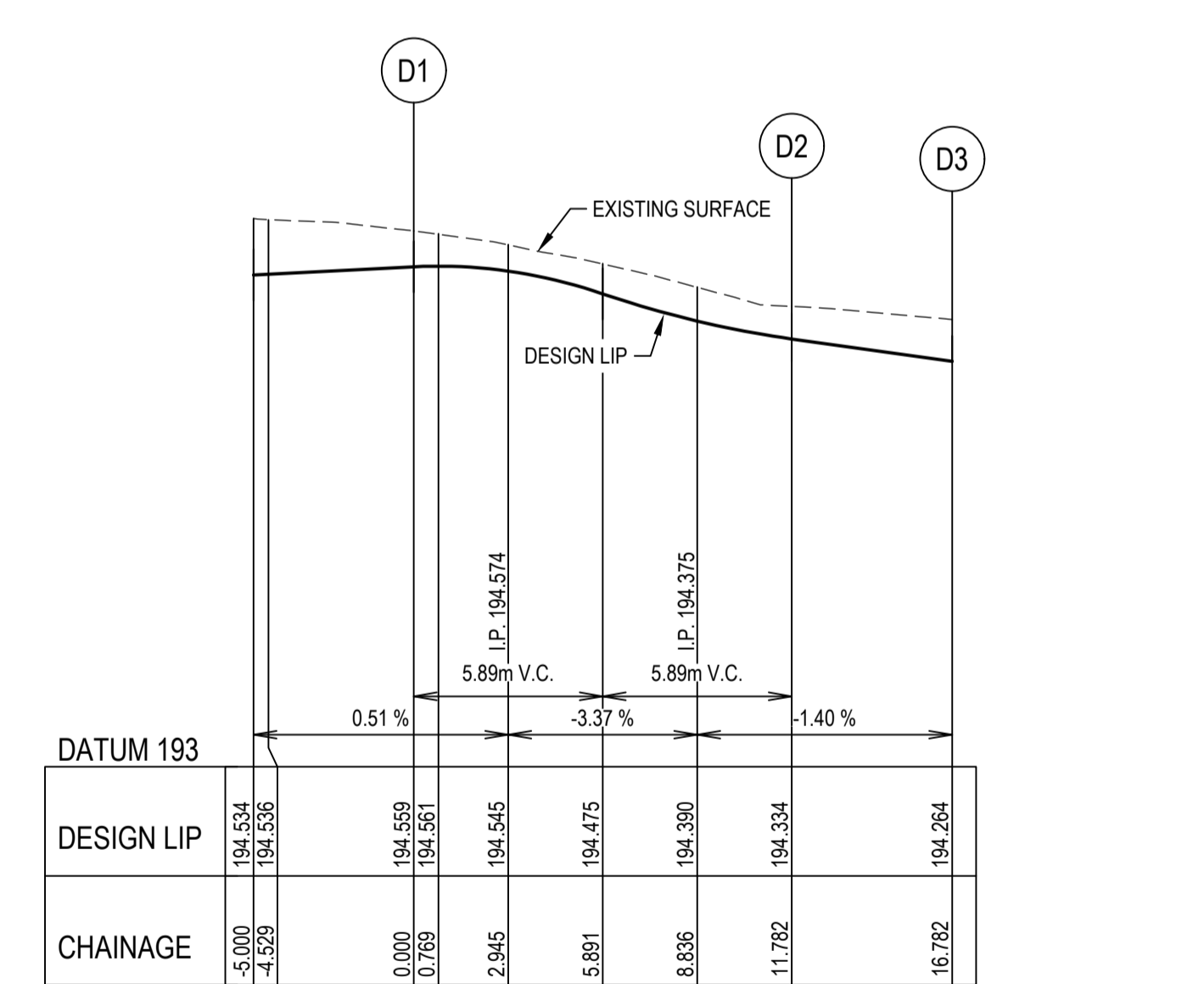
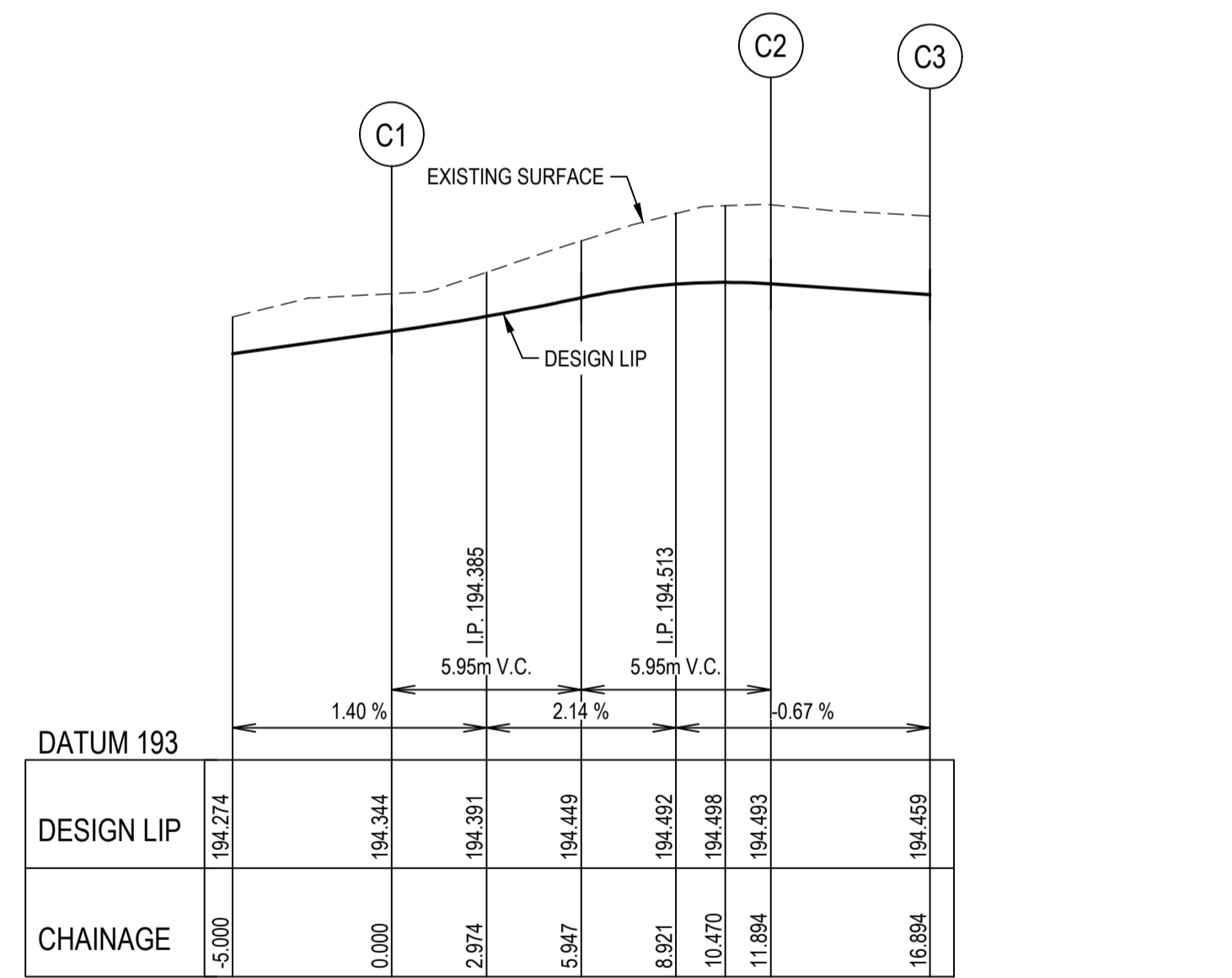
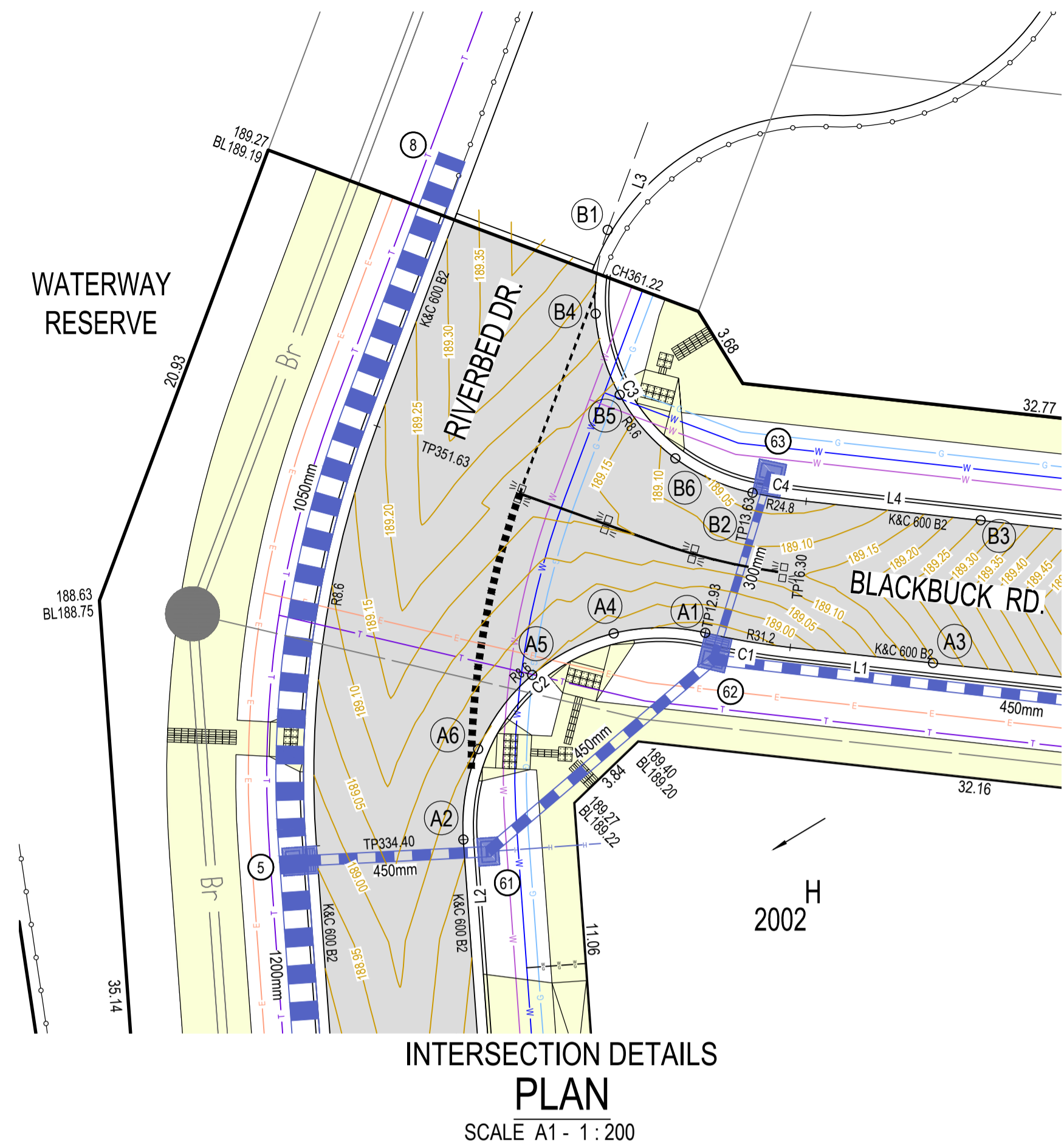

SETOUT TABLE				LIP LINE C						
PT No.	EAST.	NORTH.	LEVEL	TAG	CHAINAGE	EASTING	NORTHING	LENGTH	RADIUS	A.Length
C1	322264.98	5837550.68	194.344	L5	IP	-5.000	322260.114	5837549.545	5.000	-
C2	322271.63	5837559.41	194.493	L5	TP	0.000	322264.984	5837550.678	-	-
C3	322271.42	5837564.40	194.459	C5	TP	7.120	322271.918	5837552.292	11.894	8.6
C4	322267.71	5837551.83	194.394	C5	TP	11.894	322271.627	5837559.406	-	-
C5	322269.88	5837553.85	194.449	L6	IP	11.894	322271.627	5837559.406	5.000	-
C6	322271.24	5837556.47	194.492	L6	TP	16.894	322271.423	5837564.402	-	-

SETOUT TABLE				LIP LINE D						
PT No.	EAST.	NORTH.	LEVEL	TAG	CHAINAGE	EASTING	NORTHING	LENGTH	RADIUS	A.Length
D1	322275.53	5837539.49	194.559	L7	IP	-5.000	322277.877	5837535.082	0.471	-
D2	322265.76	5837544.29	194.334	L7	TP	-4.529	322277.635	5837535.486	-	-
D3	322260.89	5837543.15	194.264	C6	TP	-4.529	322277.635	5837535.486	4.529	41.3
D4	322273.87	5837541.91	194.544	C6	TP	-2.262	322276.472	5837537.432	-	-
D5	322271.50	5837543.63	194.475	C7	TP	0.000	322275.528	5837539.493	-	-
D6	322268.69	5837544.46	194.393	C7	IP	7.026	322275.528	5837539.493	11.782	8.6
				C7	TP	11.782	322265.759	5837544.288	-	-
				L8	IP	11.782	322265.759	5837544.288	5.000	-
				L8	TP	16.782	322260.889	5837543.154	-	-

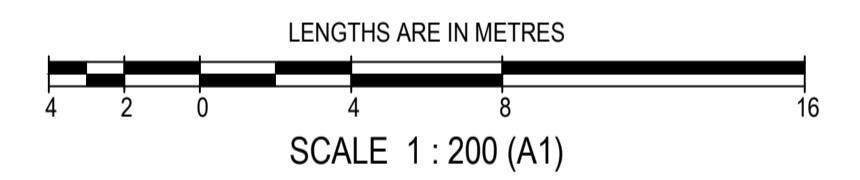
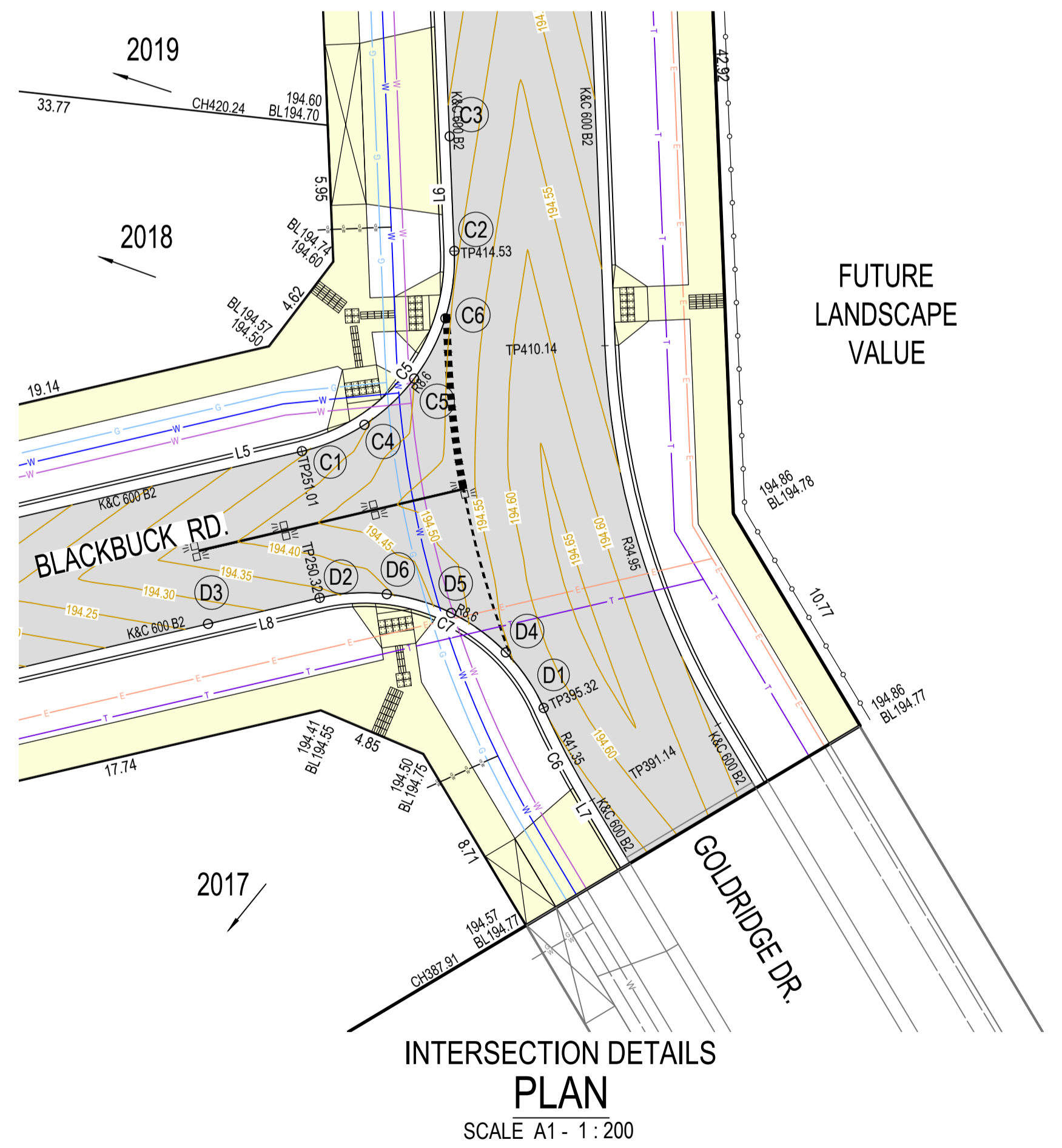

WARNING
BEWARE OF UNDERGROUND SERVICES
THE LOCATION OF UNDERGROUND SERVICES ARE APPROXIMATE ONLY AND THEIR EXACT POSITION SHOULD BE PROVEN ON SITE. NO GUARANTEE IS GIVEN THAT ALL EXISTING SERVICES ARE SHOWN.

SYMBOL LEGEND		SYMBOL LEGEND	
Prop	Prev Stage	Ex Natural/FS Level	+28.57
S	S	FS @ Building Line	+28.28.57
W	W	Top/Toe of Batter	+10P28.57
H	H	Top Ret. Wall Level	+10E28.57
PSM	PSM	100yr Flood Level	+FL28.57
Rock Ret Wall	Rock Ret Wall	Fill Proposed (<0.3m/±0.3m)	
Sleeper Ret Wall	Sleeper Ret Wall	Cut Proposed	
Conduits 50mm	GW	Asphalt Surface Prop	
Conduits 100mm	W100	Concrete Surface Prop	
Street Tree without/with Passive Irrigation (Refer Detail)	Ex W	Tree To Be Removed	
Ex Drains	Ex S	Tree To Be Retained with Tree Protection Zone (TPZ)	
Ex Water DW/NDW	Ex G		
Ex Sewer/Gas	Ex E		
Ex Elect/Comm	Ex T		

KERB LIP PROFILES
SCALE A1 - 1:200H 1:20V

breese pitt dixon pty. ltd.
land surveyors civil engineers

1/19 cato street hawthorn east. 3123 telephone 8823 2300 fax no. 8823 2310

RATHDOWNE ESTATE
STAGE 20
INTERSECTION DETAILS - SHEET 1

MUNICIPALITY WHITTLESEA
REFERENCE 9365 E/20

AMENDMENTS

VER	DATE	REMARKS
-----	------	---------

CHECKED R.GOULD-WILLIAMS
SCALE AS SHOWN DATUM AHD
DATE Aug 22
SHEET 4 OF 14

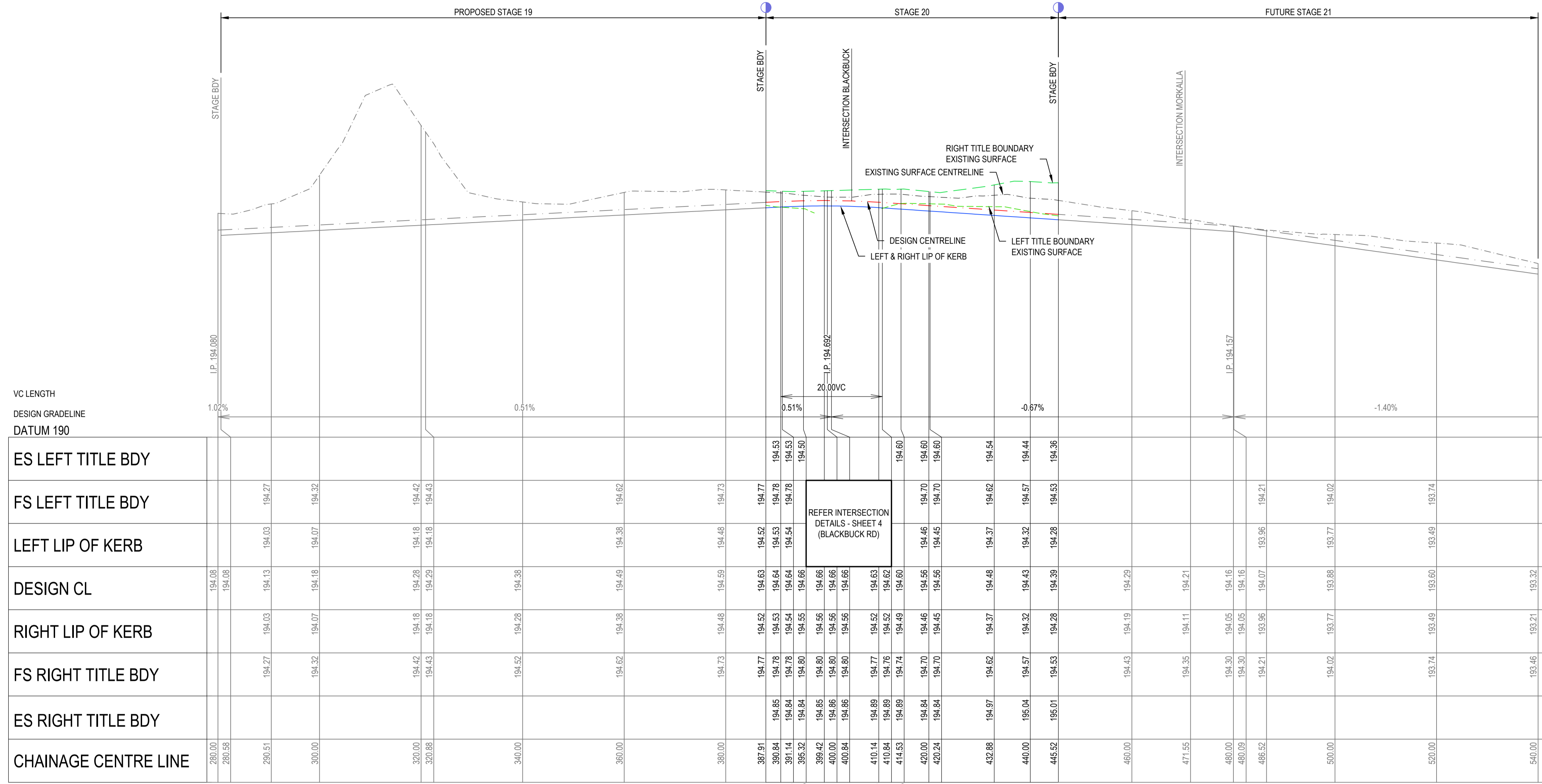

**GOLDRIDGE DR
LONGITUDINAL SECTION**

SCALE A1 - 1:500H 1:50V

SCALE H 1:500 V 1:50 @ A1

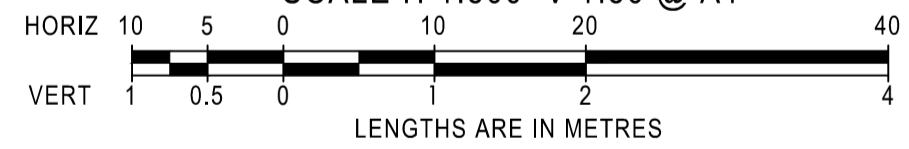

LEGEND:

- ES LEFT TITLE BOUNDARY
- DESIGN CENTRELINE
- LIP OF KERB
- ES RIGHT TITLE BOUNDARY
- ES CENTRELINE

<p align="center"> breese pitt dixon pty. ltd. land surveyors civil engineers </p>		1/19 cato street hawthorn east, 3123 telephone 8823 2300 fax no. 8823 2310									
		MUNICIPALITY WHITTLESEA									
		REFERENCE 9365 E/20									
		GOLDRIDGE DR LONGITUDINAL SECTION									
AMENDMENTS	MELWAY REF.	<table border="1"> <tr> <td>SURVEY</td> <td>B.P.D.</td> </tr> <tr> <td>DESIGN</td> <td>B.P.D.</td> </tr> <tr> <td>DRAWN</td> <td>M.T.</td> </tr> <tr> <td>CHECKED</td> <td>R.G.W.</td> </tr> </table>		SURVEY	B.P.D.	DESIGN	B.P.D.	DRAWN	M.T.	CHECKED	R.G.W.
SURVEY	B.P.D.										
DESIGN	B.P.D.										
DRAWN	M.T.										
CHECKED	R.G.W.										
VER	DATE	REMARKS	SCALE AS SHOWN	DATUM AHD	DATE Aug 22	SHEET 5 OF 14	P1				

Printed Aug 11, 2022 - 04:39pm

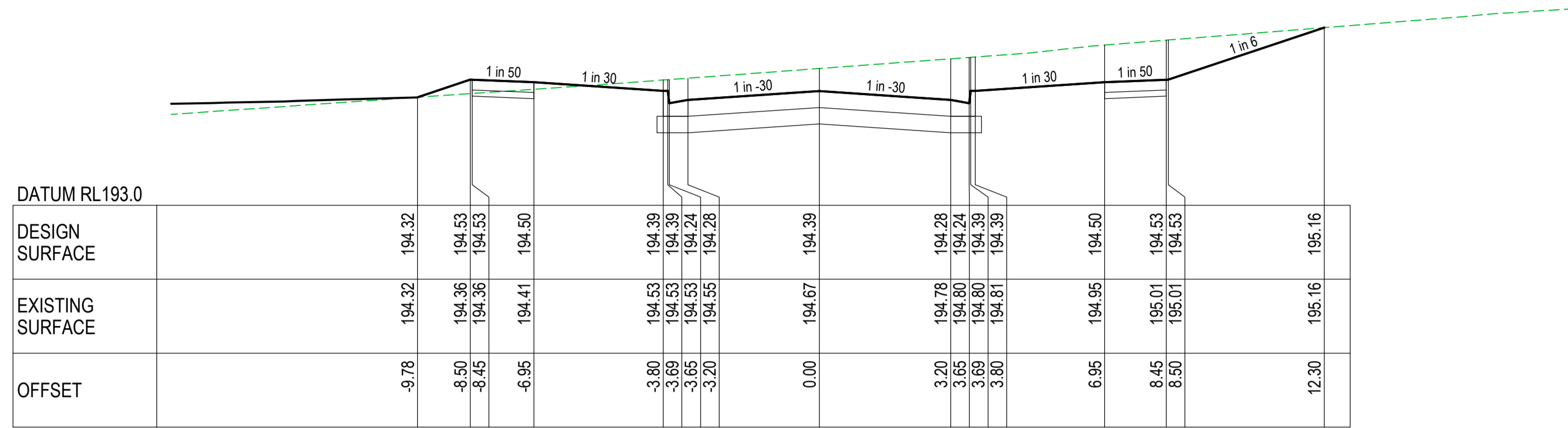

CH 445.52

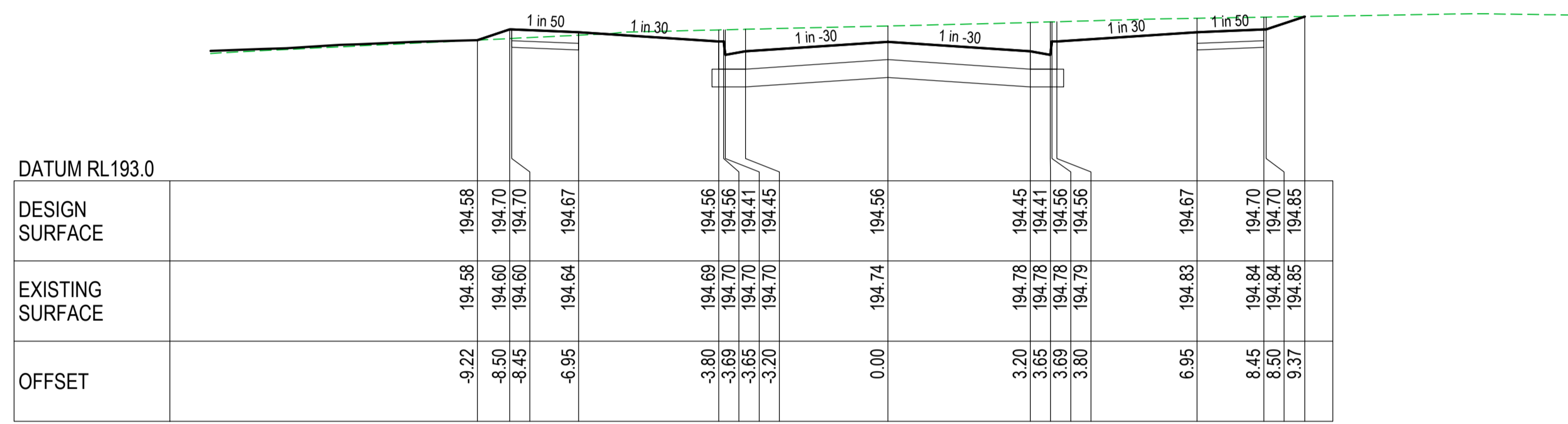

CH 420.24

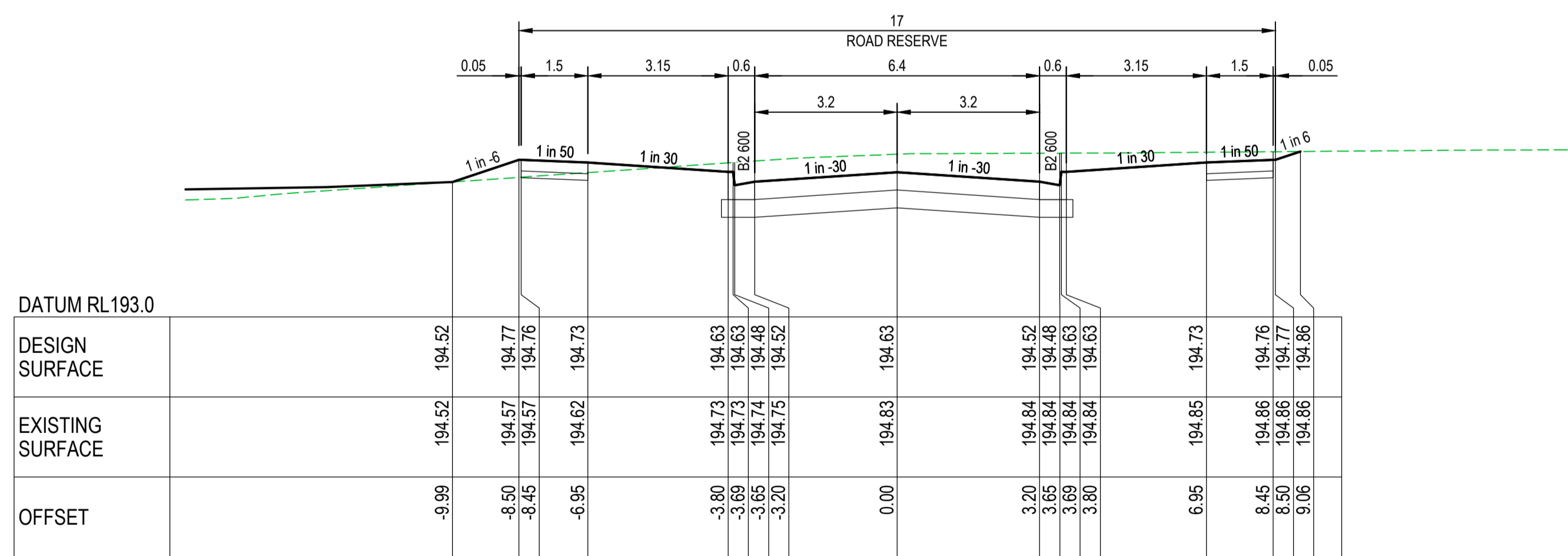

CH 387.91

GOLDRIDGE DRIVE
CROSS SECTIONS
SCALE A1 - 1:100H 1:50V

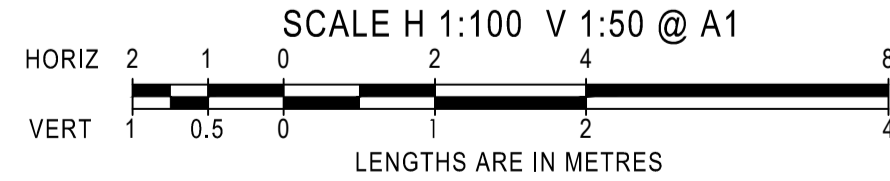

- LEGEND:
- EXISTING SURFACE LEVEL
 - DESIGN CENTRELINE
 - ▨ TYPE A SELECTED MATERIAL FILL

AMENDMENTS				breese pitt dixon pty. ltd. land surveyors civil engineers		1/19 cato street hawthorn east, 3123 telephone 8823 2300 fax no. 8823 2310	
		MELWAY REF.		RATHDOWNE ESTATE STAGE 20 GOLDRIDGE DRIVE CROSS SECTIONS		MUNICIPALITY	
		SURVEY B.P.D.				WHITTLESEA	
		DESIGN B.P.D.				REFERENCE	
		DRAWN M.T.				9365 E/20	
VER	DATE	REMARKS	CHECKED R.G.W.	SCALE AS SHOWN	DATUM AHD	DATE Aug 22	SHEET 6 OF 14

Printed Aug 11, 2022 - 0:59pm

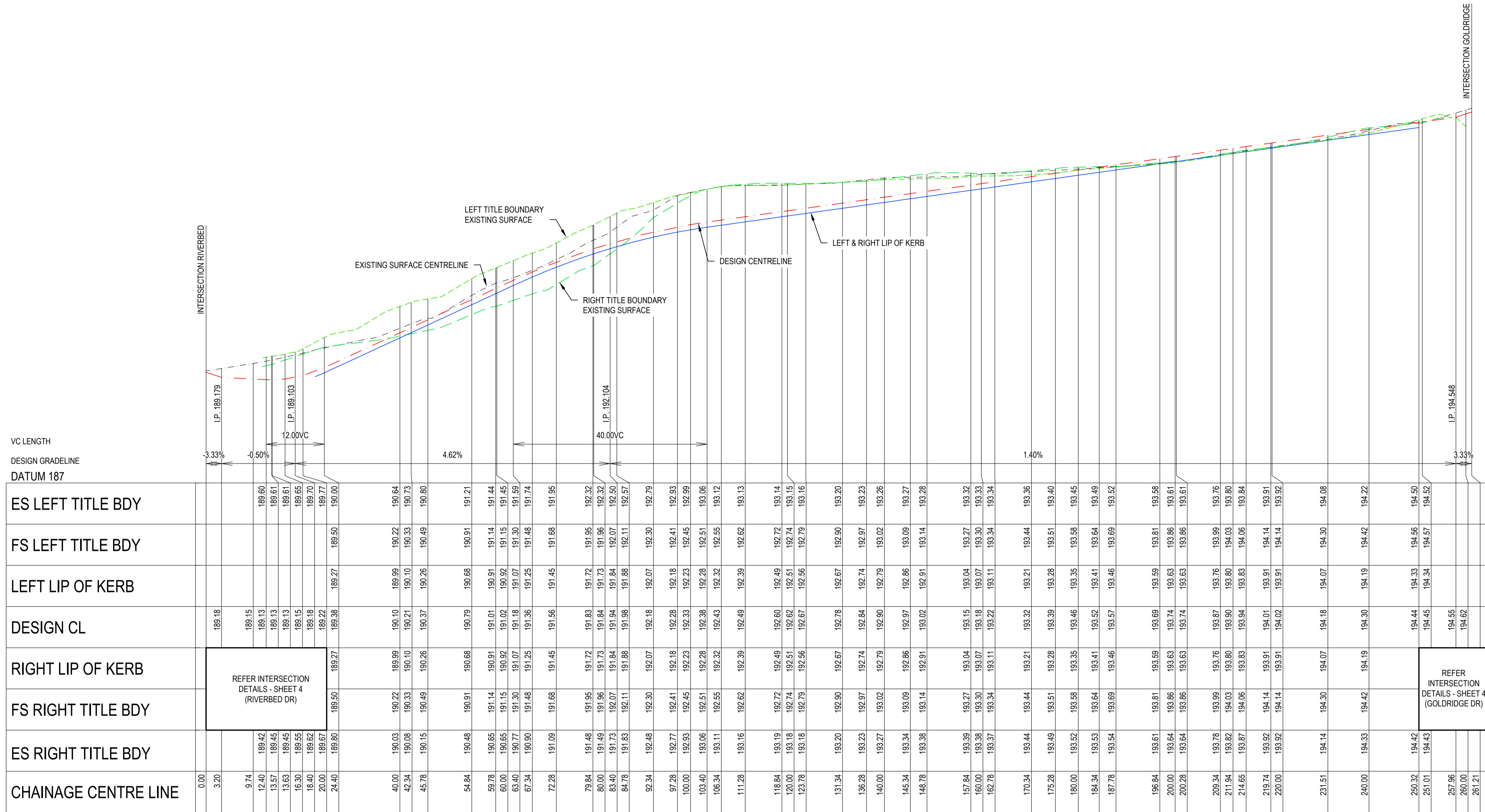

VC LENGTH	DESIGN GRADELINE	DATUM 187
ES LEFT TITLE BDY	189.18, 189.15, 189.13, 189.61, 189.65, 189.70, 189.77, 190.00	0.00, 3.20, 9.74, 12.40, 13.63, 16.30, 18.40, 20.00, 24.40
FS LEFT TITLE BDY	189.99, 190.22, 190.33, 190.49, 190.68, 190.91, 191.14, 191.44, 191.45, 191.59, 191.74, 191.95	40.00, 42.34, 45.78, 54.84, 59.78, 60.00, 63.40, 67.34, 72.28
LEFT LIP OF KERB	189.99, 190.10, 190.21, 190.37, 190.56, 190.79, 191.01, 191.14, 191.02, 191.18, 191.25, 191.45	40.00, 42.34, 45.78, 54.84, 59.78, 60.00, 63.40, 67.34, 72.28
DESIGN CL	189.18, 189.15, 189.13, 189.61, 189.65, 189.70, 189.77, 190.00	0.00, 3.20, 9.74, 12.40, 13.63, 16.30, 18.40, 20.00, 24.40
RIGHT LIP OF KERB	REFER INTERSECTION DETAILS - SHEET 4 (RIVERBED DR)	REFER INTERSECTION DETAILS - SHEET 4 (RIVERBED DR)
FS RIGHT TITLE BDY	189.50, 189.27, 189.99, 190.22, 190.33, 190.49, 190.68, 190.91, 191.14, 191.44, 191.45, 191.59, 191.74, 191.95	200.00, 209.34, 211.94, 214.65, 219.74, 220.00, 231.51, 240.00, 250.32, 251.01, 257.96, 260.00, 261.21
ES RIGHT TITLE BDY	189.50, 189.27, 189.99, 190.22, 190.33, 190.49, 190.68, 190.91, 191.14, 191.44, 191.45, 191.59, 191.74, 191.95	200.00, 209.34, 211.94, 214.65, 219.74, 220.00, 231.51, 240.00, 250.32, 251.01, 257.96, 260.00, 261.21
CHAINAGE CENTRE LINE	189.18, 189.15, 189.13, 189.61, 189.65, 189.70, 189.77, 190.00	0.00, 3.20, 9.74, 12.40, 13.63, 16.30, 18.40, 20.00, 24.40

**BLACKBUCK RD
LONGITUDINAL SECTION**

SCALE A1 - 1:500H 1:50V

SCALE H 1:500 V 1:50 @ A1

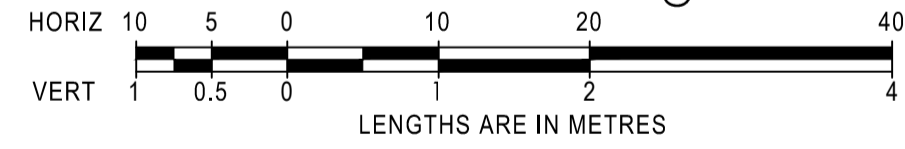

- LEGEND:**
- ES LEFT TITLE BOUNDARY
 - DESIGN CENTRELINE
 - LIP OF KERB
 - ES RIGHT TITLE BOUNDARY
 - ES CENTRELINE

AMENDMENTS				breese pitt dixon pty. ltd. land surveyors civil engineers		1/19 cato street hawthorn east, 3123 telephone 8823 2300 fax no. 8823 2310	
MELWAY REF.	SURVEY	B.P.D.	RATHDOWNE ESTATE STAGE 20		MUNICIPALITY		WHITTLESEA
DESIGN	B.P.D.	REFERENCE					
DRAWN	M.T.	BLACKBUCK RD LONGITUDINAL SECTION		9365 E/20		SHEET 7 OF 14 P1	
CHECKED	R.G.W.	SCALE	AS SHOWN	DATUM	AHD	DATE	Aug 22

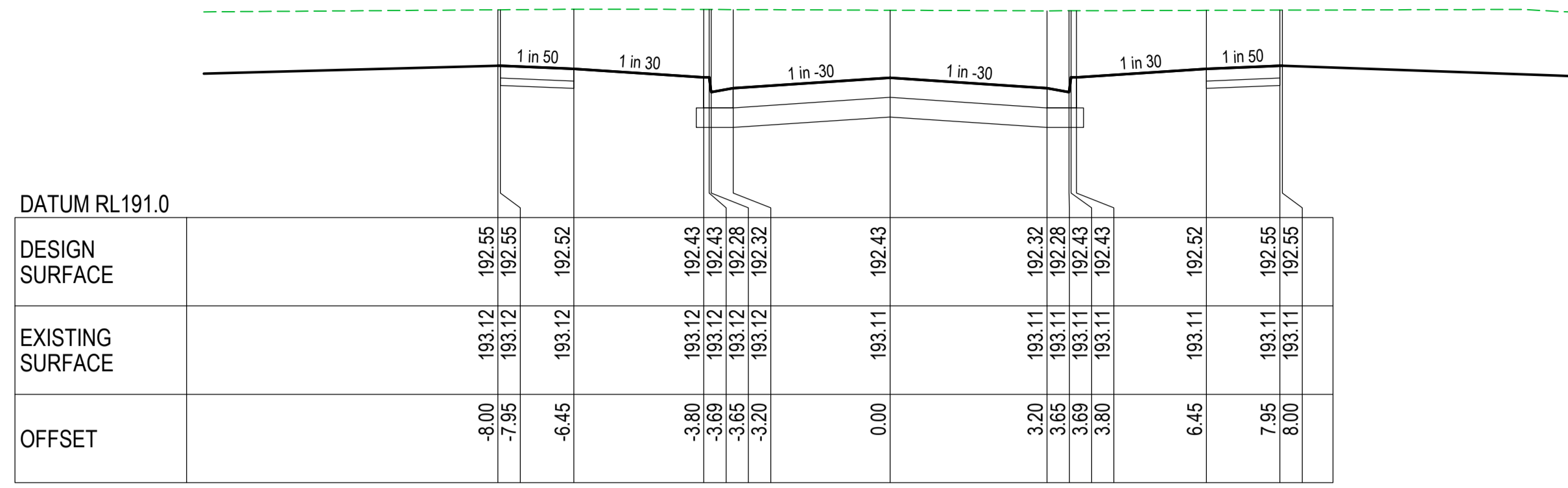

CH 106.34

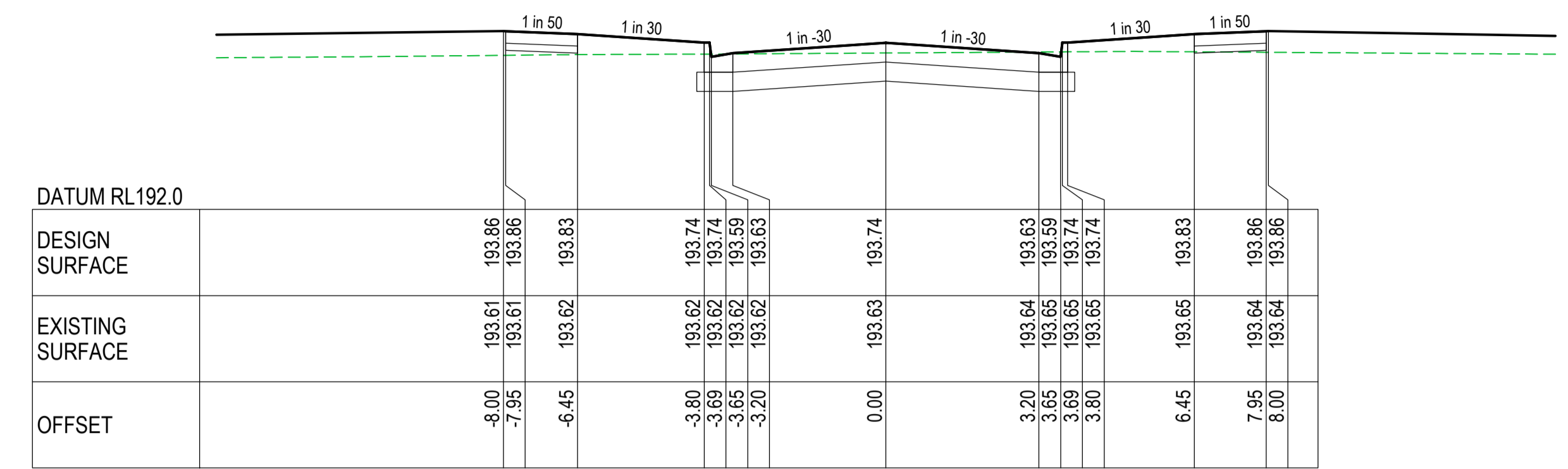

CH 200.28

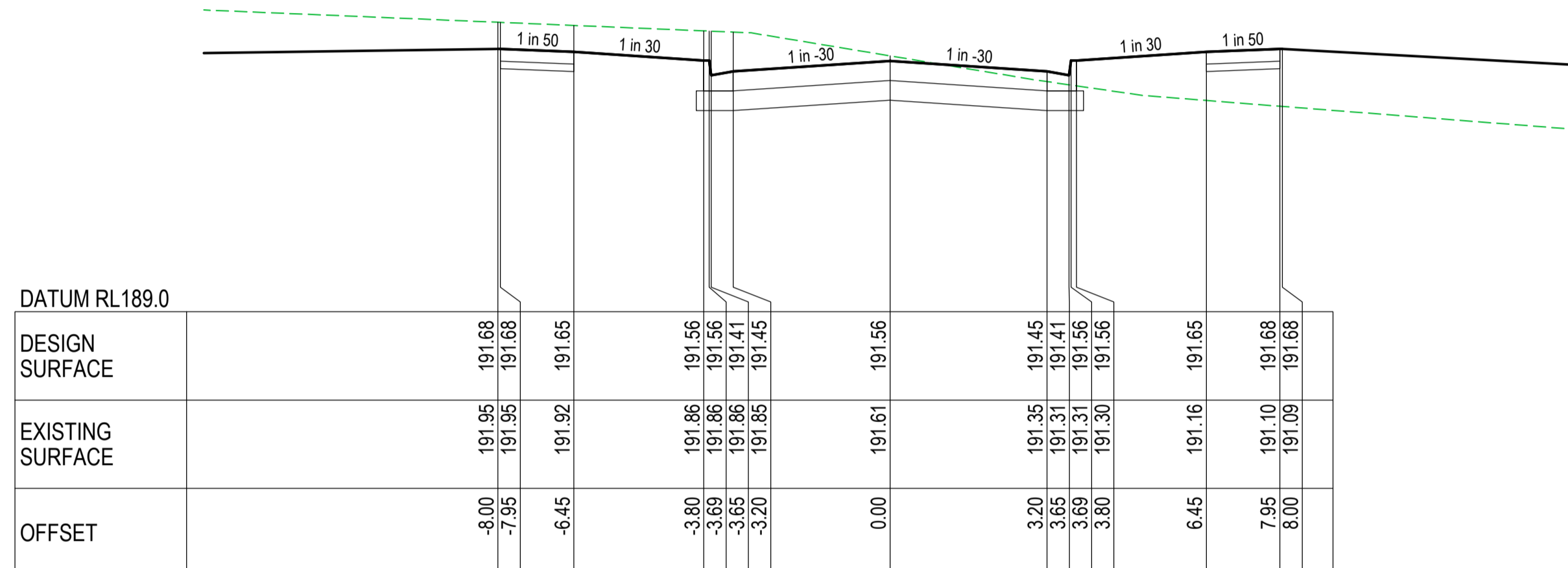

CH 72.28

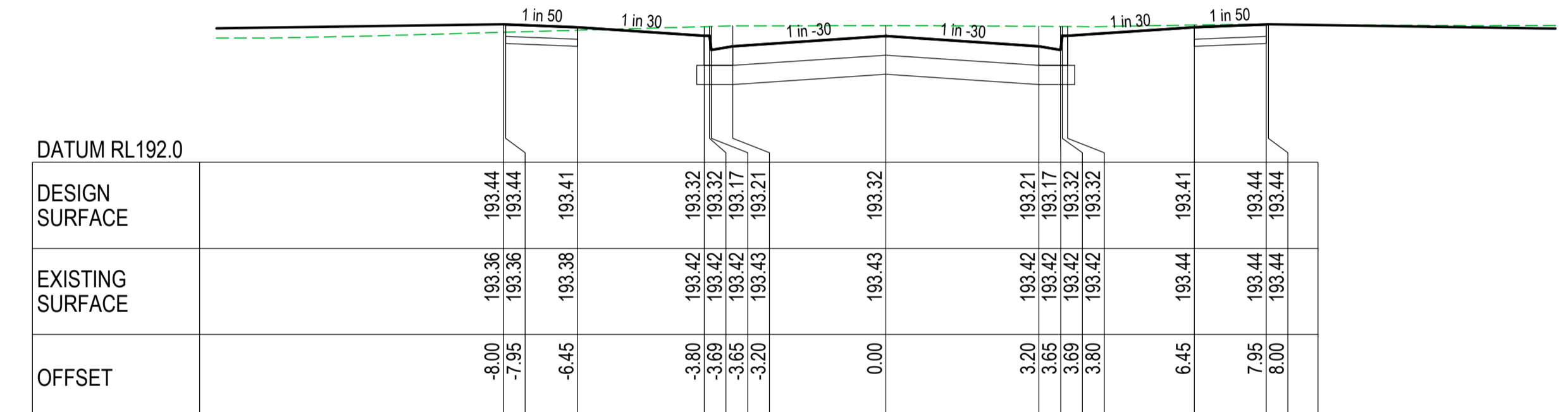

CH 170.34

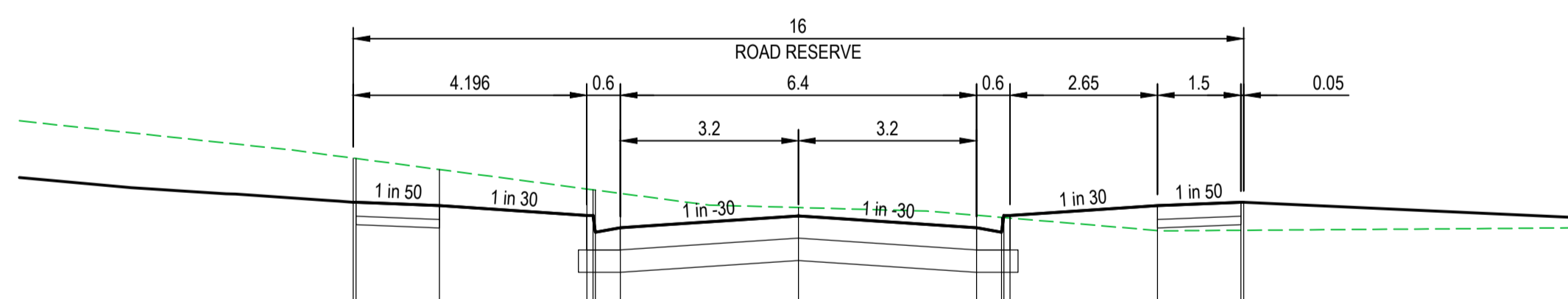

CH 42.34

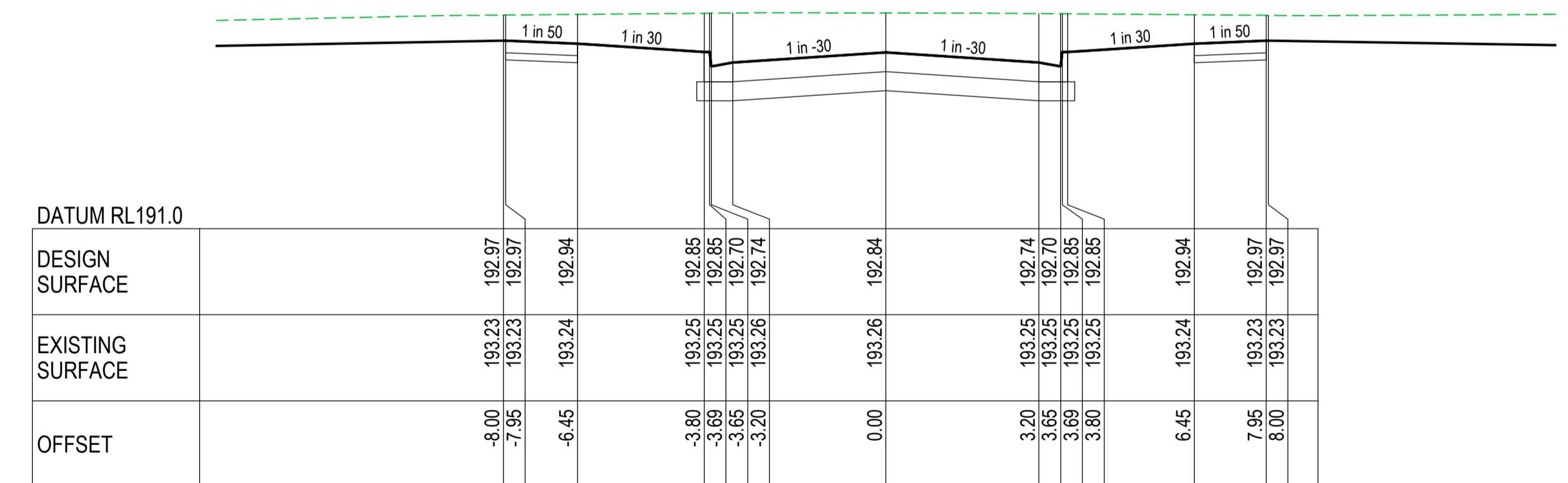

CH 136.28

**BLACKBUCK ROAD
CROSS SECTIONS**
SCALE A1 - 1:100H 1:50V

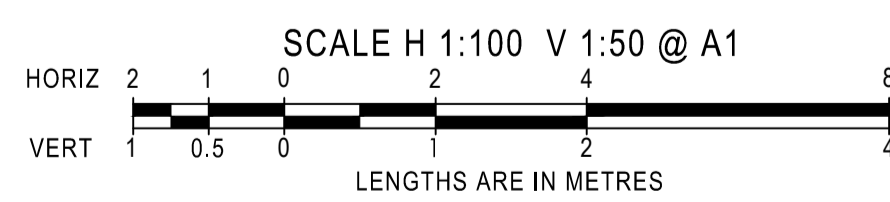

LEGEND:
 --- EXISTING SURFACE LEVEL
 --- DESIGN CENTRELINE
 TYPE A SELECTED MATERIAL FILL

		1/19 cato street hawthorn east, 3123 telephone 8823 2300 fax no. 8823 2310	
MUNICIPALITY WHITTLESEA		REFERENCE 9365 E/20	
RATHDOWNE ESTATE STAGE 20		BLACKBUCK RD CROSS SECTIONS	
MELWAY REF.	SURVEY	SCALE	DATUM
	B.P.D.	AS SHOWN	AHD
DESIGN	B.P.D.	DATE	Aug 22
DRAWN	M.T.	SHEET	8 OF 14
CHECKED	R.G.W.	DATE	Aug 22
VER	DATE	REMARKS	

Printed Aug 11, 2022 - 05:30pm

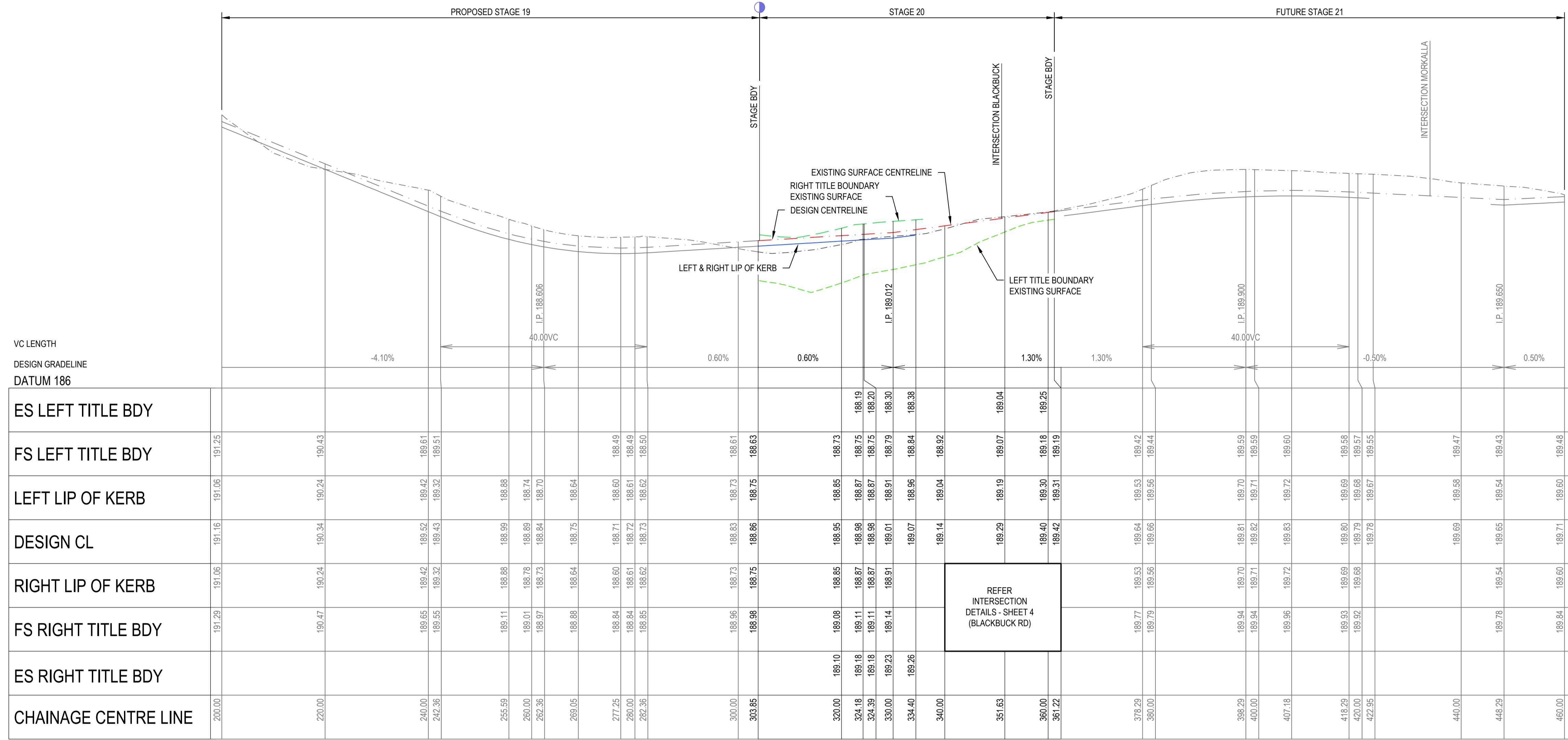

RIVERBED DR
LONGITUDINAL SECTION
SCALE A1 - 1:500H 1:50V

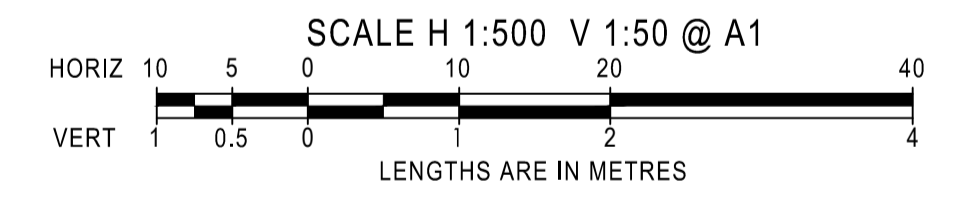

- LEGEND:
- ES LEFT TITLE BOUNDARY
 - DESIGN CENTRELINE
 - LIP OF KERB
 - ES RIGHT TITLE BOUNDARY
 - ES CENTRELINE

AMENDMENTS				breese pitt dixon pty. ltd. land surveyors civil engineers		1/19 cato street hawthorn east, 3123 telephone 8823 2300 fax no. 8823 2310	
MELWAY REF.		SURVEY B.P.D.		RATHDOWNE ESTATE STAGE 20		MUNICIPALITY WHITTLESEA	
DESIGN B.P.D.		DRAWN M.T.				REFERENCE 9365 E/20	
CHECKED R.G.W.		SCALE AS SHOWN		DATUM AHD		DATE Aug 22	
SHEET 9 OF 14		P1		RIVERBED DR LONGITUDINAL SECTION		SHEET 9 OF 14 P1	

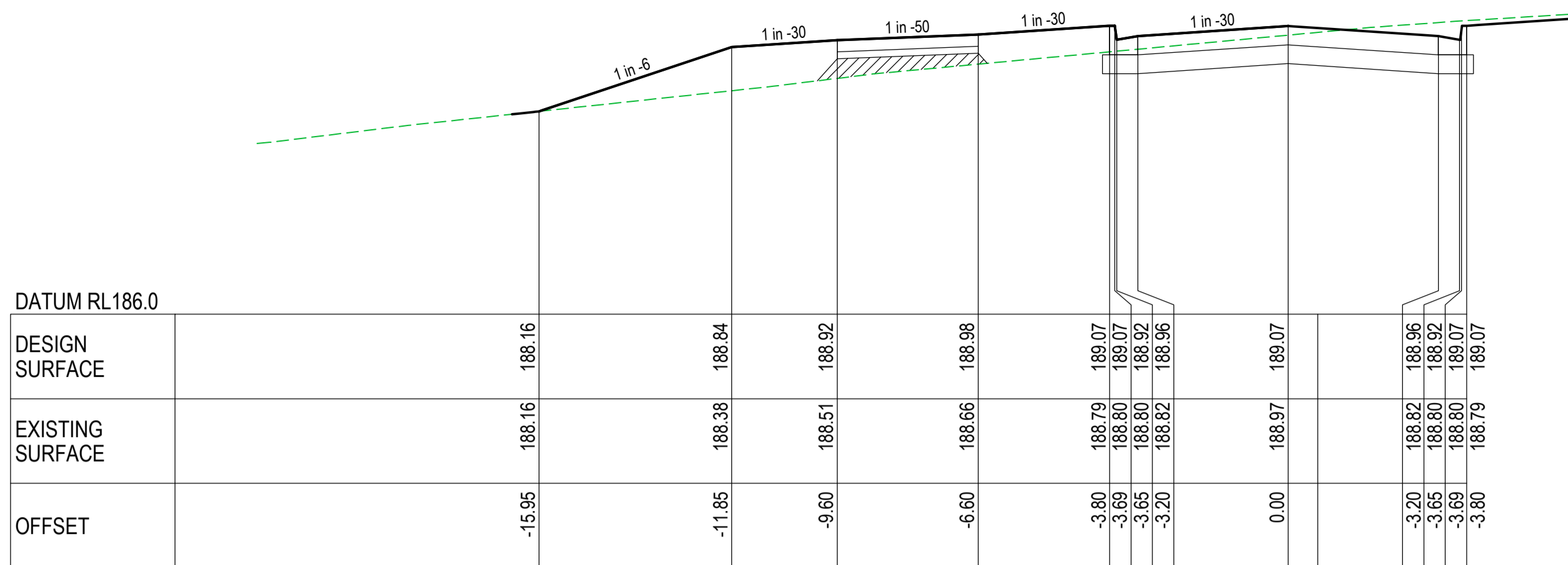

CH 334.40

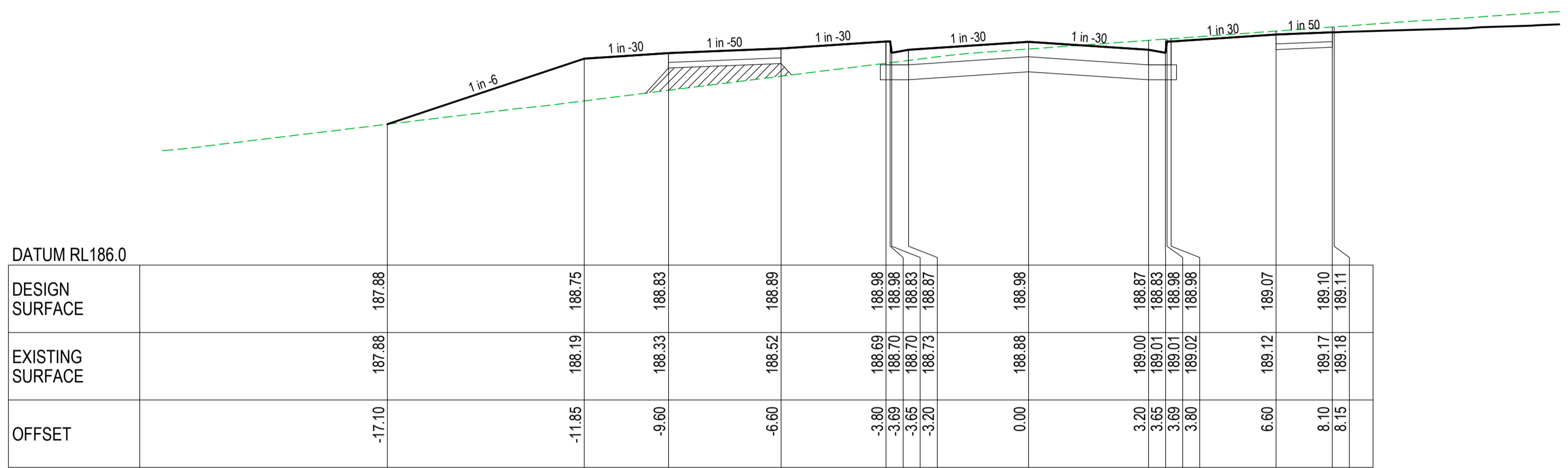

CH 324.18

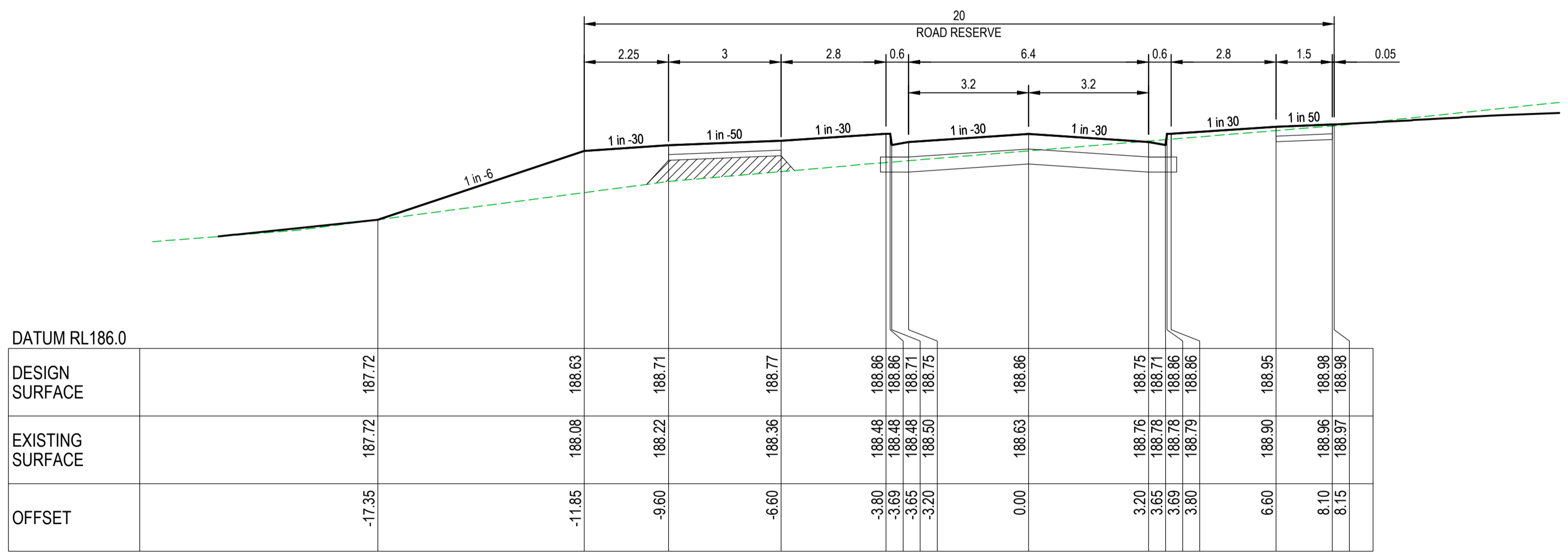

CH 304.20

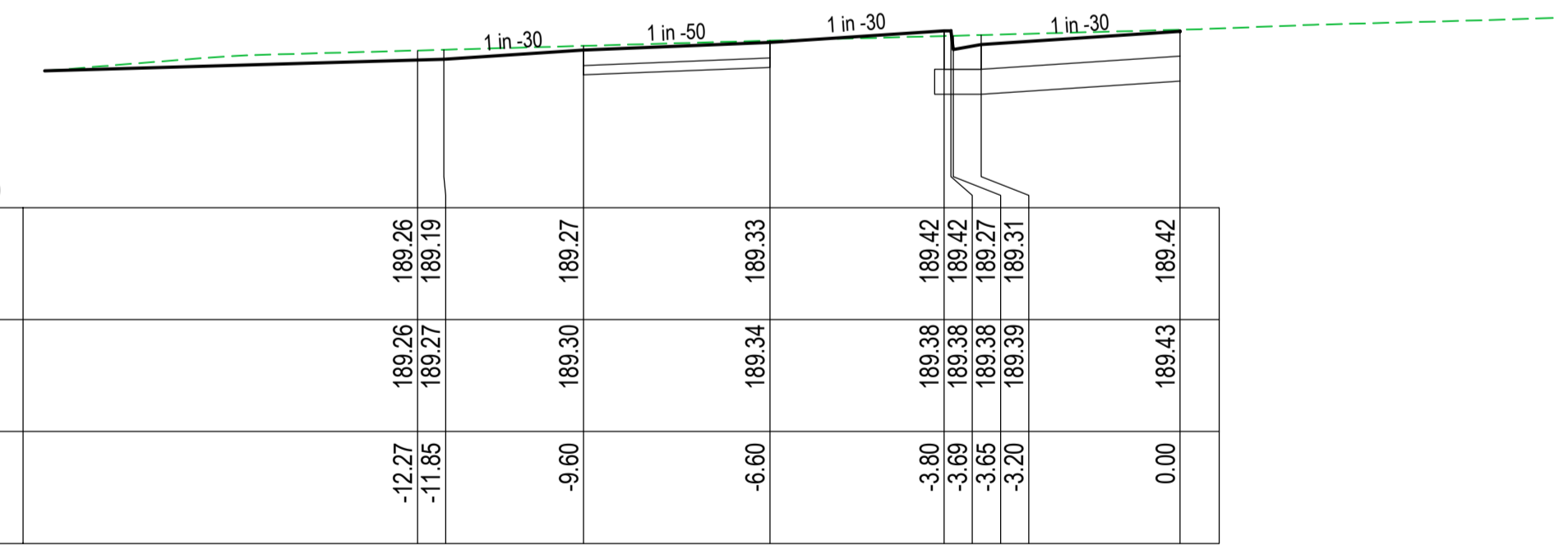

CH 361.22

RIVERBED DRIVE
CROSS SECTIONS

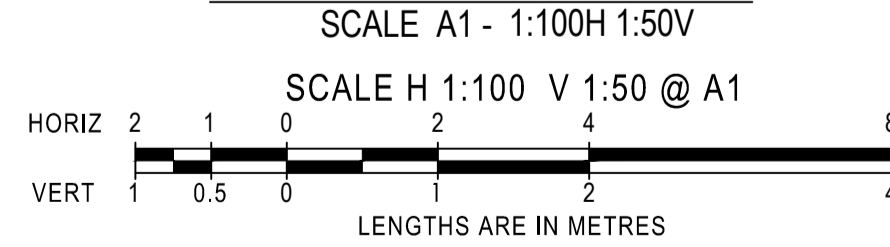

LEGEND:
 - - - - - EXISTING SURFACE LEVEL
 ——— DESIGN CENTRELINE
 ▨ TYPE A SELECTED MATERIAL FILL

AMENDMENTS		 land surveyors civil engineers		1/19 cato street hawthorn east, 3123 telephone 8823 2300 fax no. 8823 2310	
MELWAY REF.		RATHDOWNE ESTATE STAGE 20 RIVERBED DR CROSS SECTIONS		MUNICIPALITY WHITTLESEA REFERENCE 9365 E/20	
DATE	REMARKS	CHECKED	R.G.W.	SCALE	AS SHOWN
DATE	REMARKS	DRAWN	M.T.	DATUM	AHD
DATE	REMARKS	SURVEY	B.P.D.	DATE	Aug 22
DATE	REMARKS	DESIGN	B.P.D.	SHEET	10 OF 14
DATE	REMARKS	VER			P7

Printed Aug 11, 2022 - 05:42pm

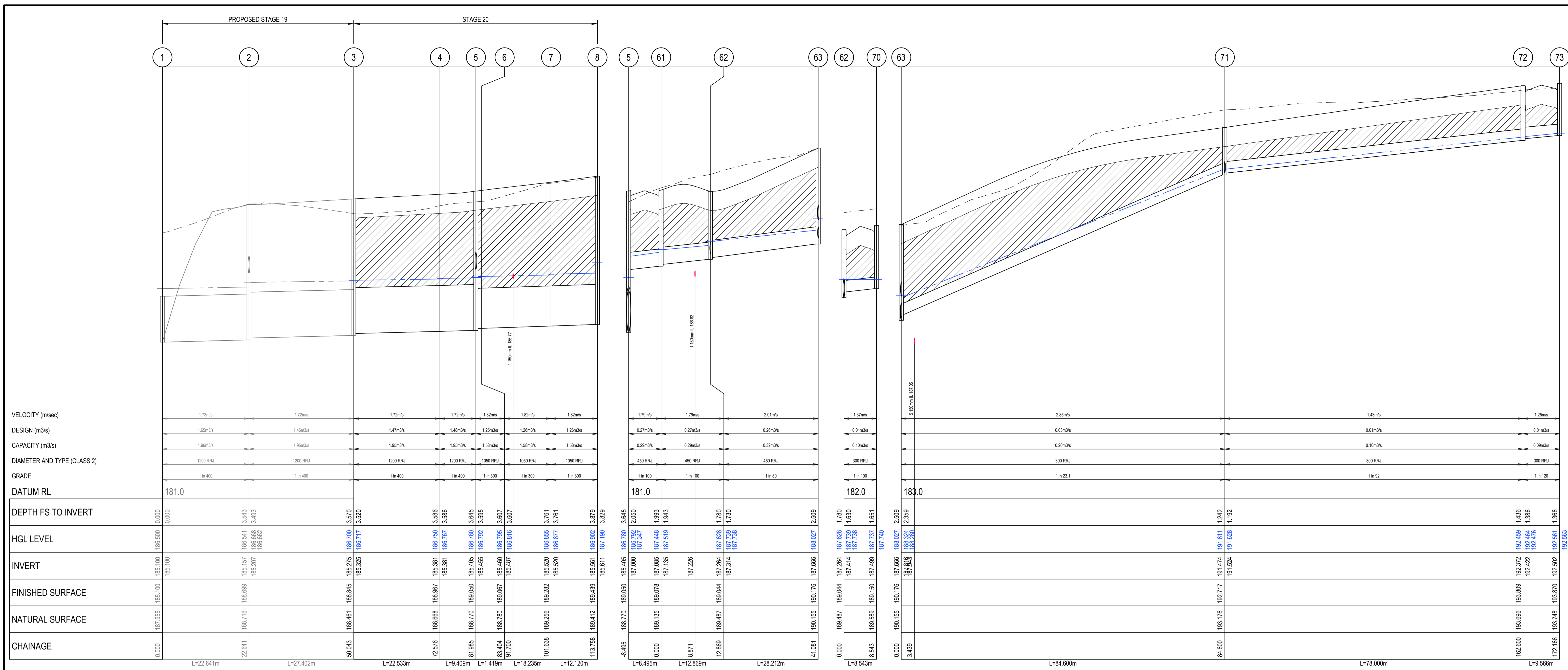

DRAINAGE LONGITUDINAL SECTIONS

SCALE A1 - 1:500H 1:50V

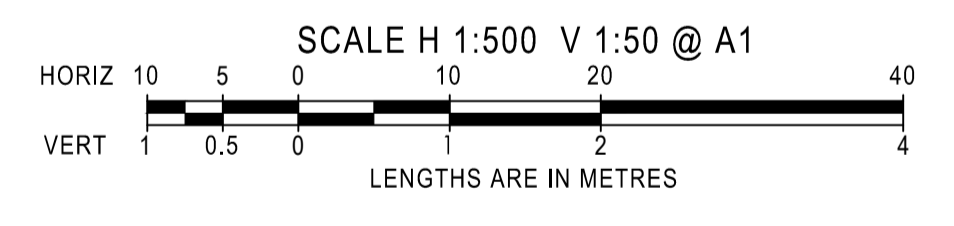

- LEGEND:**
- INDICATES CRUSHED ROCK BACKFILL
 - INDICATES 5 YEAR HGL
 - INDICATES 10 YEAR HGL

 breese pitt dixon pty. ltd. land surveyors civil engineers		1/19 cato street hawthorn east, 3123 telephone 8823 2300 fax no. 8823 2310	
		MUNICIPALITY WHITTLESEA	
		REFERENCE 9365 E/20	
		SHEET 11 OF 14 P1	
MELWAY REF. SURVEY B.P.D. DESIGN B.P.D. DRAWN M.T.		RATHDOWNE ESTATE STAGE 20 DRAINAGE LONGITUDINAL SECTIONS - SHEET 1	
AMENDMENTS	VER	DATE	REMARKS
CHECKED	R.G.W.	SCALE	AS SHOWN
DATUM	AHD	DATE	Aug 22

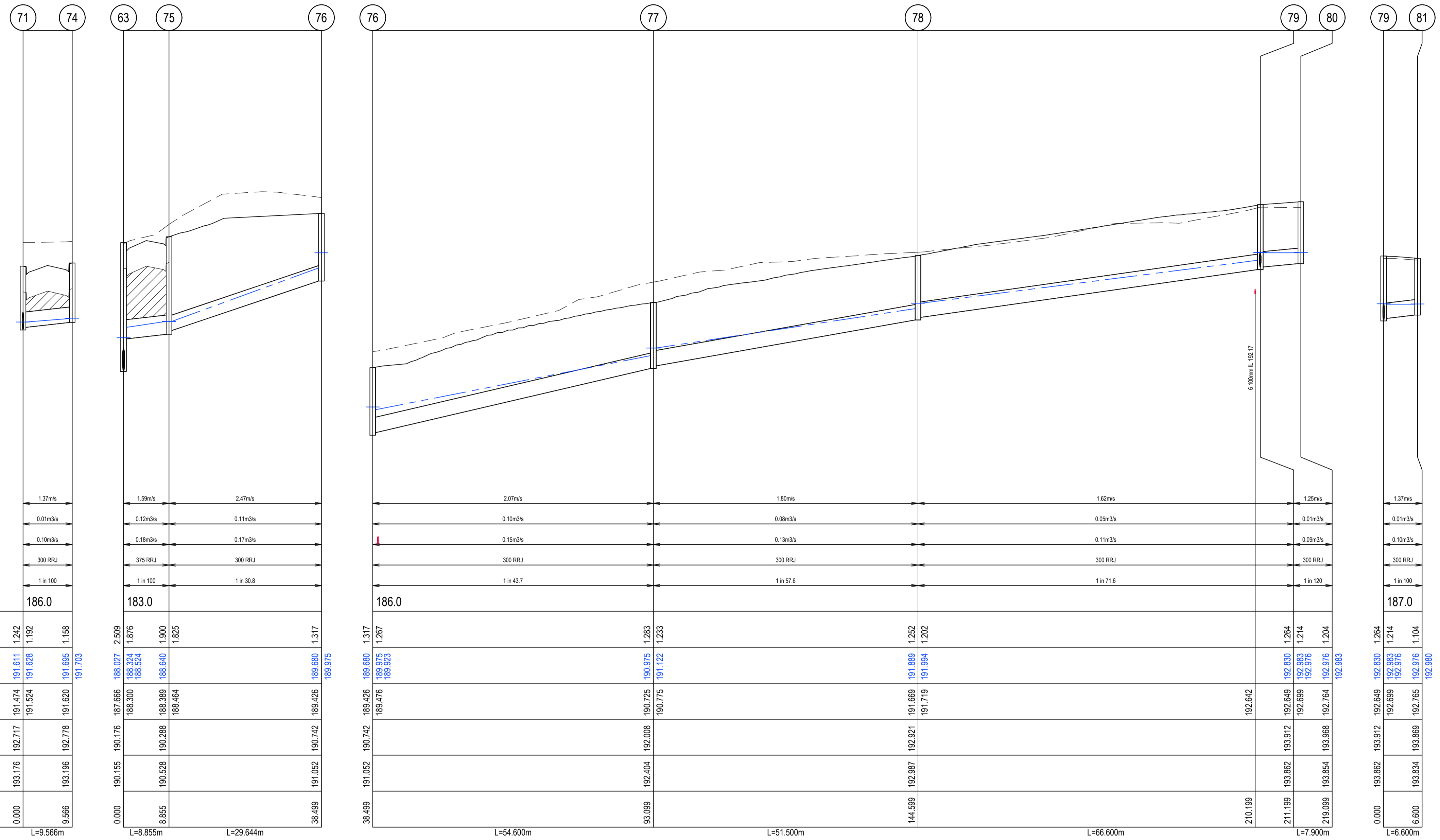

DRAINAGE LONGITUDINAL SECTIONS

SCALE A1 - 1:500H 1:50V

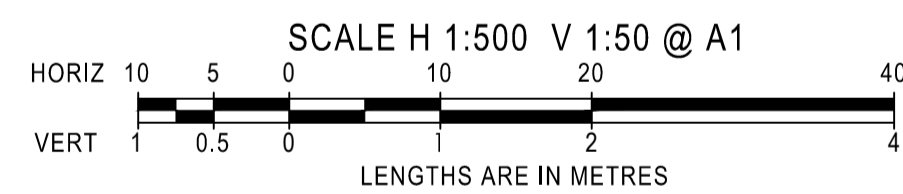

LEGEND:

- INDICATES CRUSHED ROCK BACKFILL
- INDICATES 5 YEAR HGL
- INDICATES 10 YEAR HGL

AMENDMENTS		 breese pitt dixon pty. ltd. land surveyors civil engineers	1/19 cato street hawthorn east, 3123 telephone 8823 2300 fax no. 8823 2310	
	MELWAY REF. 678-H8		RATHDOWNE ESTATE STAGE 20	MUNICIPALITY MACEDON RANGES
	SURVEY B.P.D.		DRAINAGE LONGITUDINAL SECTIONS - SHEET 2	REFERENCE 9987 E/20
	DESIGN B.P.D.		DRAWN M.T.	SHEET 12 OF 14
DATE	REMARKS	CHECKED J.TALBOT	SCALE AS SHOWN DATUM AHD DATE Aug 22 SHEET 12 OF 14 P1	

PIT SCHEDULE

PIT No.	PIT DESCRIPTION	LENGTH	WIDTH	INLET		OUTLET		TOP	DEPTH	REMARKS
				INVERT	DIA	INVERT	DIA	PIT RL	INVERT	
3	JUNCTION PIT (EXISTING)	1500	900	185.325	1200	185.275	1200	188.845	3.57	CONNECT TO EXISTING JUNCTION PIT
4	TP			185.381	1200	185.381	1200	188.967	3.586	
5	SIDE ENTRY PIT	1500	900	185.455	1050	185.405	1200	189.05	3.645	EDCM STD DRG 601 (HAUNCHED)
5				187	450			189.05	3.695	
6	TP			185.46	1050	185.46	1050	189.067	3.607	
7	TP			185.52	1050	185.52	1050	189.282	3.762	
8	END OF PIPE (FUTURE JUNCTION PIT)					185.561	1050	189.439	3.878	CAP END FOR FUTURE CONNECTION
61	JUNCTION PIT	900	900	187.135	450	187.085	450	189.078	1.993	EDCM STD DRG 605
62				187.314	450	187.264	450	189.044	1.78	
62				187.414	300			189.044	1.78	
63	SIDE ENTRY PIT	900	900	187.741	375	187.666	450	190.176	2.509	EDCM STD DRG 601
63				187.816	300			190.176	2.509	
63				188.3	375			190.176	2.509	
64	JUNCTION PIT	900	600	188.202	300	188.127	375	189.672	1.545	EDCM STD DRG 605
65	JUNCTION PIT	900	600	190.896	300	190.846	300	192.077	1.231	EDCM STD DRG 605
66	JUNCTION PIT	900	600	191.897	300	191.847	300	193.09	1.243	EDCM STD DRG 605
67	JUNCTION PIT	900	600	192.698	300	192.648	300	193.932	1.285	EDCM STD DRG 605
68	JUNCTION PIT	900	600	192.918	300	192.868	300	194.21	1.342	EDCM STD DRG 605
69	JUNCTION PIT	900	600			193.029	300	194.23	1.201	EDCM STD DRG 605
70	SIDE ENTRY PIT	900	600			187.499	300	189.15	1.651	EDCM STD DRG 601
71	SIDE ENTRY PIT	900	600	191.524	300	191.474	300	192.717	1.242	EDCM STD DRG 601
71				191.524	300			192.717	1.242	
72	SIDE ENTRY PIT	900	600	192.422	300	192.372	300	193.809	1.436	EDCM STD DRG 601
73	SIDE ENTRY PIT	900	600			192.502	300	193.87	1.368	EDCM STD DRG 601
74	SIDE ENTRY PIT	900	600			191.62	300	192.778	1.158	EDCM STD DRG 601
75	SIDE ENTRY PIT	900	600	188.464	300	188.389	375	190.288	1.9	EDCM STD DRG 601
76	JUNCTION PIT	900	600	189.476	300	189.426	300	190.742	1.317	EDCM STD DRG 605
77	JUNCTION PIT	900	600	190.775	300	190.725	300	192.008	1.283	EDCM STD DRG 605
78	JUNCTION PIT	900	600	191.719	300	191.669	300	192.921	1.252	EDCM STD DRG 605
79	JUNCTION PIT	900	600	192.699	300	192.649	300	193.912	1.264	EDCM STD DRG 605
79				192.699	300			193.912	1.264	
80	JUNCTION PIT	900	600			192.764	300	193.968	1.204	EDCM STD DRG 605
81	JUNCTION PIT	900	600			192.765	300	193.869	1.104	EDCM STD DRG 605

STORMWATER PIT NOTES:

1. ALL PITS TO BE RENDERED & MORTARED WITH FLAT BASE (NO CHASE). PIT BASES ARE TO BE FLUSH WITH PIPE INVERTS
2. ALL PIPES TO BE CUT FLUSH WITH PIT WALL
3. ALL PIT COVERS TO BE FIBRE GLASS TYPE ONLY
4. ALL GRATED PIT COVERS TO BE PEDESTRIAN & CYCLIST SAFE

AMENDMENTS				 breese pitt dixon pty. ltd. land surveyors civil engineers	1/19 cato street hawthorn east, 3123 telephone 8823 2300 fax no. 8823 2310			
				RATHDOWNE ESTATE STAGE 20 DRAINAGE PIT SCHEDULE	MUNICIPALITY WHITTLESEA REFERENCE 9365 E/20			
VER	DATE	REMARKS	CHECKED R.GOULD-WILLIAMS	SCALE AS SHOWN	DATUM AHD	DATE Aug 22	SHEET 13 OF 14	P7

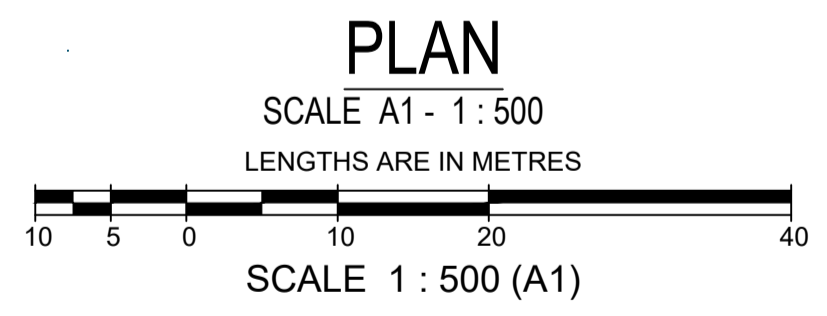
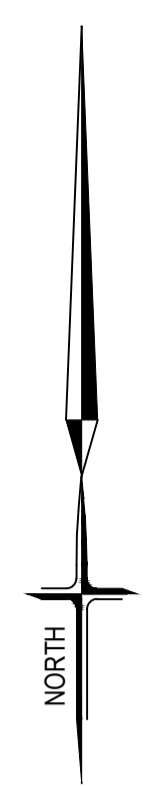

LEGEND - SIGNAGE

A STREET SIGNS

B TURN SIGNS (W1-1AL & W1-1AR) - CLASS 1 WITH 20km/h SPEED ADVISORY SIGN (W8-2A)

C GIVE WAY SIGN - CLASS 1

D ROAD CLOSED SIGN (G9-20) WITH OBSTRUCTION MARKER SIGN (D4-5) - CLASS 1

NOTES:

- ALL SIGNS TO BE SLEEVED USING A SL27 SLEEVE WITH A MINIMUM OF 2 WEDGES
- ALL SIGNES TO BE INSTALLED IN ACCORDANCE WITH MCC205
- INDICATES UNI-DIRECTIONAL & BI-DIRECTIONAL RRPM'S PLACED AT 3m CTRS
- SWLM - INDICATES SOLID WHITE 'LONGLIFE' LINEMARKING. BWLM - INDICATE BROKEN WHITE 'LONGLIFE' LINEMARKING

AMENDMENTS				breese pitt dixon pty. ltd. land surveyors civil engineers	RATHDOWNE ESTATE STAGE 20 SIGNAGE & LINEMARKING PLAN	MUNICIPALITY	1/19 cato street hawthorn east, 3123 telephone 8823 2300 fax no. 8823 2310			
						WHITTLESEA				
						REFERENCE	9365 E/20			
						SHEET	14 OF 14	P7		
VER	DATE	REMARKS	CHECKED	R.GOULD-WILLIAMS	SCALE	AS SHOWN	DATUM	AHD	DATE	June 22