

**SHEET INDEX**

SHT No.	VER	Description
1	P1	LAYOUT PLAN SHEET 1 OF 2
2	P1	LAYOUT PLAN SHEET 2 OF 2
3	P1	TYPICAL CROSS SECTIONS
4	P1	ROAD PAVEMENT DETAILS & NOTES
5	P1	GENERAL DETAILS
6	P1	ROAD PAVEMENT DETAILS
7	P1	TRANSFORMER SITE DETAILS
8	P1	INTERSECTION DETAIL PLANS - 1
9	P1	INTERSECTION DETAIL PLANS - 2
10	P1	INTERSECTION DETAIL PLANS - 3
11	P1	LONGITUDINAL & CROSS SECTIONS MAMIC BOULEVARD SHEET 1 OF 2
12	P1	LONGITUDINAL & CROSS SECTIONS MAMIC BOULEVARD SHEET 2 OF 2
13	P1	LONGITUDINAL & CROSS SECTIONS MAMIC BOULEVARD (SOUTH)
14	P1	LONGITUDINAL & CROSS SECTIONS ALICIA AVENUE SHEET 1 OF 2
15	P1	LONGITUDINAL & CROSS SECTIONS ALICIA AVENUE SHEET 2 OF 2
16	P1	LONGITUDINAL & CROSS SECTIONS KENNEDY DRIVE SHEET 1 OF 2
17	P1	LONGITUDINAL & CROSS SECTIONS KENNEDY DRIVE SHEET 2 OF 2
17	P1	LONGITUDINAL & CROSS SECTIONS KENNEDY DRIVE SHEET 2 OF 2
18	P1	LONGITUDINAL & CROSS SECTIONS MARYANNE WAY SHEET 1 OF 3
19	P1	LONGITUDINAL & CROSS SECTIONS MARYANNE WAY SHEET 2 OF 3
20	P1	LONGITUDINAL & CROSS SECTIONS MARYANNE WAY SHEET 3 OF 3
21	P1	LONGITUDINAL & CROSS SECTIONS IVANHOE LANE
22	P1	DRAINAGE LONGITUDINAL SECTIONS - SHEET 1
23	P1	DRAINAGE LONGITUDINAL SECTIONS - SHEET 2
24	P1	DRAINAGE LONGITUDINAL SECTIONS - SHEET 3
25	P1	DRAINAGE LONGITUDINAL SECTIONS - SHEET 4
26	P1	DRAINAGE LONGITUDINAL SECTIONS - SHEET 5
27	P1	DRAINAGE LONGITUDINAL SECTIONS - SHEET 6
28	P1	DRAINAGE LONGITUDINAL SECTIONS - SHEET 7
29	P1	DRAINAGE STRUCTURE DETAILS
30	P1	SIGNAGE & LINEMARKING PLAN
31	P1	PASSIVE IRRIGATION PLAN
32	P1	MOBILITY PLAN
33	P1	BUS BAY DETAILS
34	P1	EARTHWORKS PLAN

**NOTE:**  
KERB CUTOFF FOR PASSIVE IRRIGATION. REFER TO DETAIL ON SHEET 5. FINAL STREET PIT LOCATION TO BE COORDINATED WITH LANDSCAPE DRAWINGS.

**ATTENTION TO CONTRACTOR**

- IT IS THE CONTRACTORS RESPONSIBILITY TO ENSURE THAT THE DIGITAL PLAN, PROVIDED FOR SETOUT PURPOSES, MATCHES THE TBM CO-ORDINATES SHOWN.
- WHERE CONCRETE WORKS ABOUT A SEWER ACCESS CHAMBER SURROUND OR SIMILAR STRUCTURE, AN EXPANSION JOINT OF APPROVAL MATERIAL SHALL BE PROVIDED BETWEEN THE TWO FACES.
- CONTRACTOR TO ENSURE THAT THE SITE IS PEGGED AND OR SET OUT CHECKED BY THE LICENCED SURVEYOR RESPONSIBLE FOR CERTIFYING THE PLAN OF SUBDIVISION PRIOR TO UNDERGROUND INFRASTRUCTURE BEING INSTALLED.

PLAN  
SCALE 1:500

**SYMBOL LEGEND**

<ul style="list-style-type: none"> <li>Prop</li> <li>Prev Stage</li> <li>Drains</li> <li>Main Drains</li> <li>Sewer &lt; 3000</li> <li>Sewer ≥ 3000</li> <li>Water (DW)</li> <li>Water (NDW)</li> <li>House Drain</li> <li>Property Inlet</li> <li>Street Sign</li> <li>PSM</li> <li>Rock Ret Wall</li> <li>Sleeper Ret Wall</li> <li>Conduits 50mm</li> <li>Conduits 100mm</li> <li>Street Tree without/with Passive Irrigation (Refer Detail)</li> <li>Ex Drains</li> <li>Ex Water/DW/NDW</li> <li>Ex Sewer/Gas</li> <li>Ex Elect/Comm</li> <li>Ex Optic Fibre</li> </ul>	<ul style="list-style-type: none"> <li>Prop</li> <li>Prev Stage</li> <li>Ex Natural/FS Level</li> <li>FS @ Building Line</li> <li>Top/Toe of Batter</li> <li>Top Ret. Wall Level</li> <li>100yr Flood Level</li> <li>Fill Proposed (&lt;0.3m/≥0.3m)</li> <li>Cut Proposed</li> <li>Asphalt Surface Prop</li> <li>Concrete Surface Prop (Paths/Driveways/Slabs)</li> <li>Tree To Be Removed</li> <li>Tree To Be Retained with Tree Protection Zone (TPZ)</li> </ul>
---	--

**WARNING**  
BEWARE OF UNDERGROUND SERVICES  
THE LOCATION OF UNDERGROUND SERVICES ARE APPROXIMATE ONLY AND THEIR EXACT POSITION SHOULD BE PROVEN ON SITE. NO GUARANTEE IS GIVEN THAT ALL EXISTING SERVICES ARE SHOWN.

PRELIMINARY LEVELS TO BE ADJUSTED DURING THE DETAILED DESIGN PHASE ONCE MW DRAINAGE SCHEME AND OVERLAND FLOWS HAVE BEEN APPROVED.

LENGTHS ARE IN METRES  
SCALE 1 : 500 (A1)

**PRELIMINARY**

		<p>land surveyors</p> <p>civil engineers</p>	<p>1/19 cato street hawthorn east, 3123 telephone 8823 2300 fax no. 8823 2310</p>						
<p>MELWAY REF. 356-C-1</p> <p>SURVEY BPD</p> <p>DESIGN J.B</p> <p>DRAWN I.W</p>		<p><b>ASPIRE ESTATE</b> <b>STAGE 31</b> <b>LAYOUT PLAN SHEET 1 OF 2</b></p>							
<p>AMENDMENTS</p> <table border="1"> <thead> <tr> <th>VER</th> <th>DATE</th> <th>REMARKS</th> </tr> </thead> <tbody> <tr> <td> </td> <td> </td> <td> </td> </tr> </tbody> </table>		VER	DATE	REMARKS				<p>MUNICIPALITY <b>MELTON</b></p> <p>REFERENCE 8226 E/31</p>	<p>SCALE AS SHOWN</p> <p>DATUM AHD</p> <p>DATE NOV '21</p> <p>SHEET 01 OF 34</p> <p>P1</p>
VER	DATE	REMARKS							

REFER SHEET 1 FOR CONTINUATION

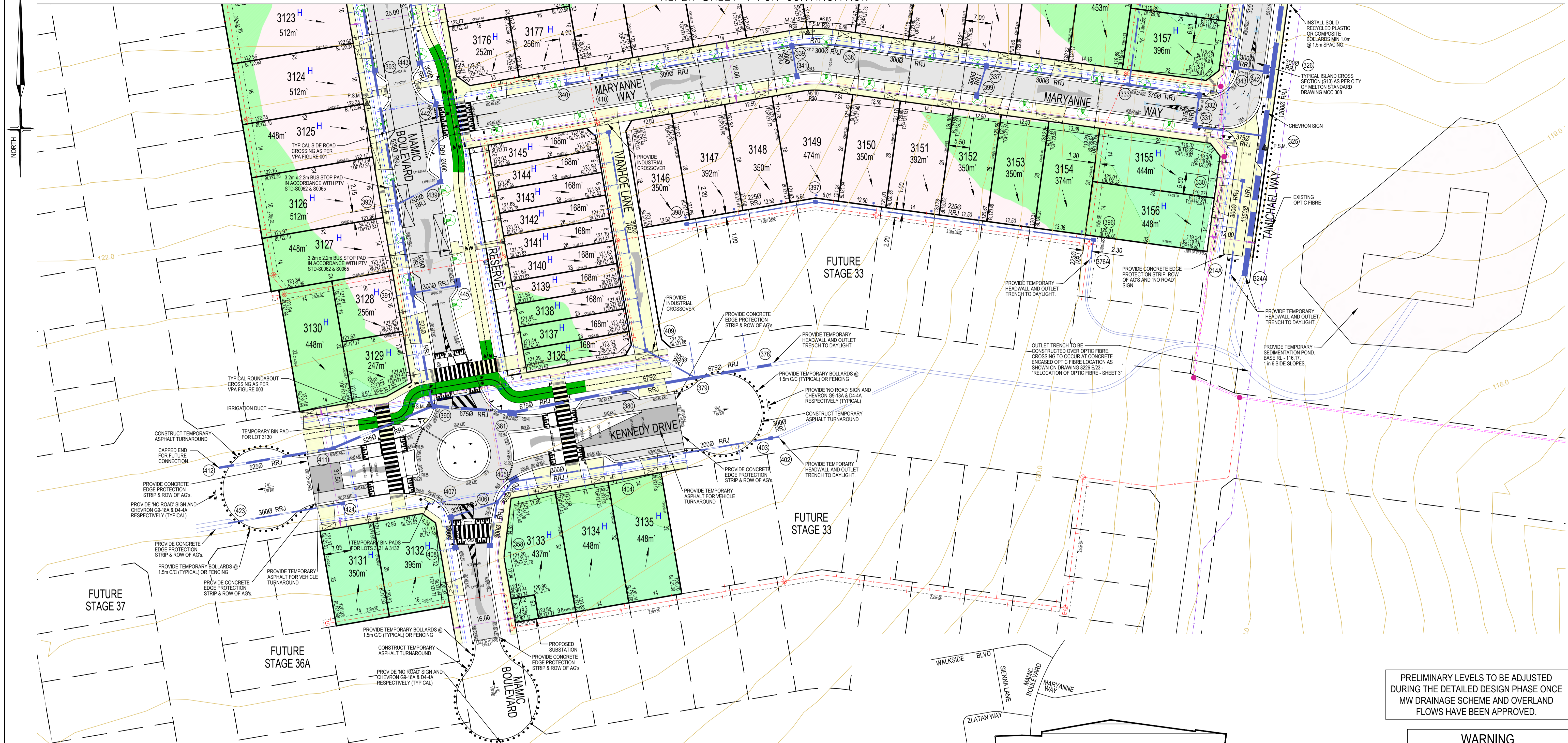

PLAN SCALE 1:500

SERVICE OFFSETS AND LOCATION TABLE

Location	Gas	Water		Telecommunications		Electricity		BOK	Road Width	Joint Trenching	Street Classification
		NDW	DW	Cables	Pits	Cables	Poles				
MAMIC BOULEVARD (NORTH)	2.10 W	2.60 W	1.95 E	1.95 E	2.70 E	1.00 BOK	4.50 W 9.00 E	25.00	G&W, FTH&E	CONNECTOR STREET	
MAMIC BOULEVARD (NORTH) & RESERVE	0.50 E	2.60 W & 1.00 E			2.20 E	1.00 BOK	4.50 W 9.00 E	25.00	G&W, FTH&E	CONNECTOR STREET	
MARYANNE WAY E/W	2.10 N	2.60 N	1.80 S	1.80 S	2.30 S	1.00 BOK	4.20 N 4.20 S	16.00	G&W, FTH&E	ACCESS PLACE	
MARYANNE WAY N/S	2.70 W	3.10 W	1.80 W	1.80 W	2.15 W	1.00 BOK	4.35 W 3.35 E	15.30	G&W, FTH&E	ACCESS PLACE	
ALICIA AVENUE	2.10 N	2.60 N	1.80 S	1.80 S	2.30 S	1.00 BOK	4.20 N 4.20 S	16.00	G&W, FTH&E	ACCESS PLACE	
MAMIC BOULEVARD (SOUTH)	2.10 W	2.60 W	1.80 E	1.80 E	2.30 E	1.00 BOK	4.20 E 4.20 W	16.00	G&W, FTH&E	ACCESS PLACE	
KENNEDY DRIVE	2.10 N	2.60 N	1.80 S	1.80 S	2.40 S	1.00 BOK	4.20 E 4.20 W	31.50	G&W, FTH&E	CONNECTOR STREET	
TAMICHAEL WAY	2.70 W	3.10 W	1.80 W	1.80 W	2.15 W		2.80 E 4.20 W	12.00	G&W, FTH&E	LANEWAY	
IVANHOE LANE							1.50 E 0.50 W	8.00	G&W, FTH&E	LANEWAY	
RESERVE NO 1			1.85 E	1.85 E						RESERVE	

NOTE: \* OFFSET FROM BACK OF KERB

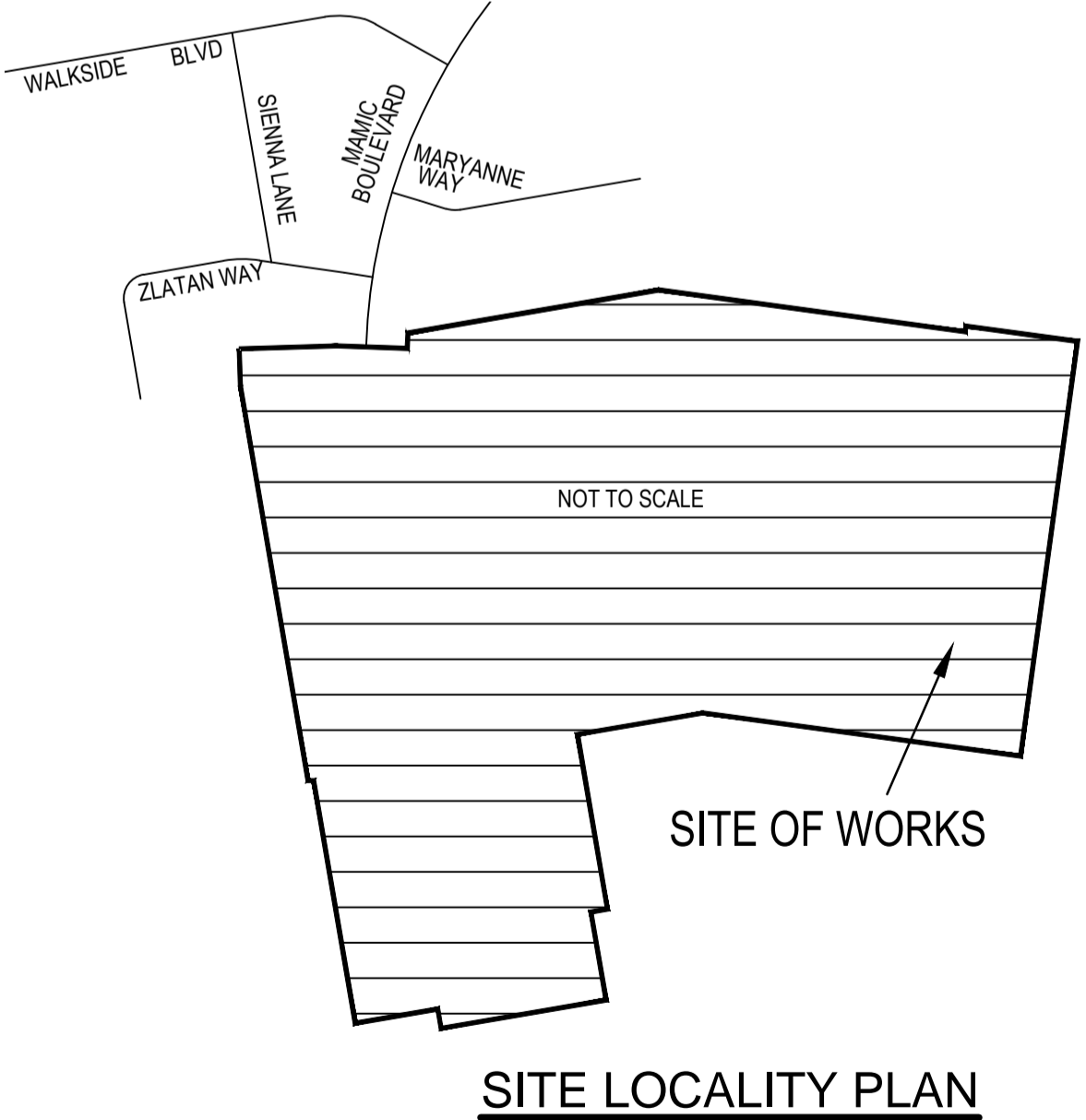
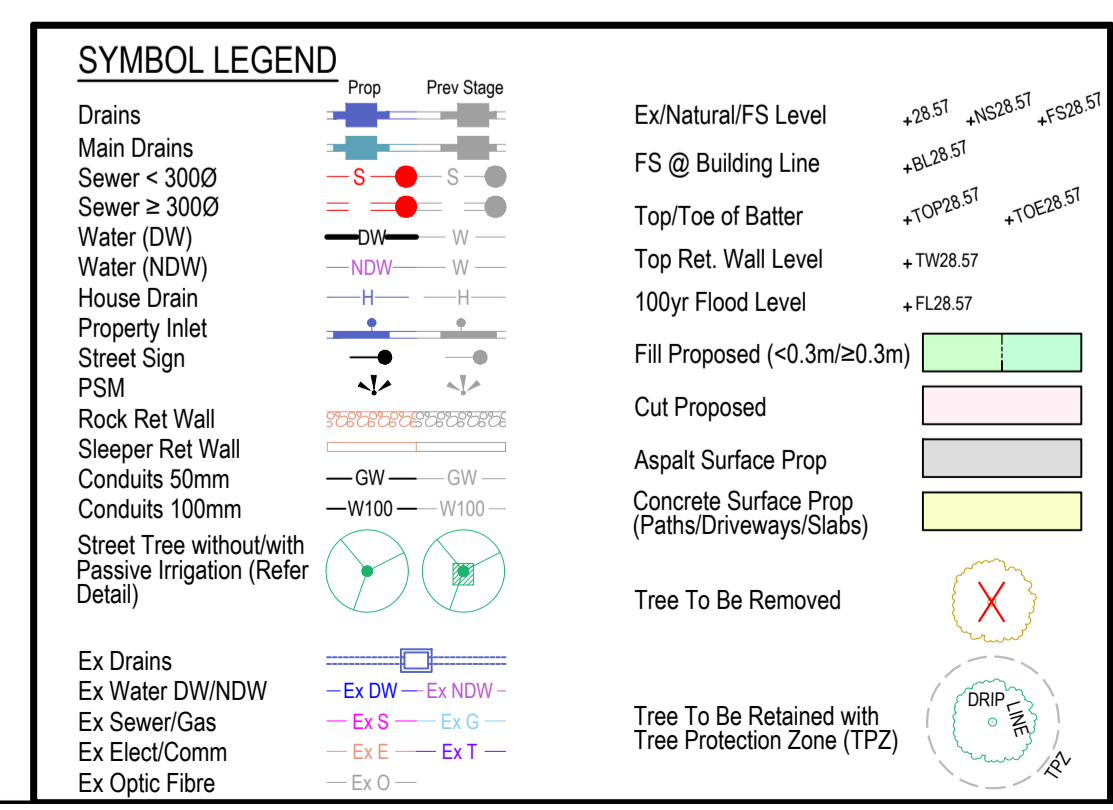
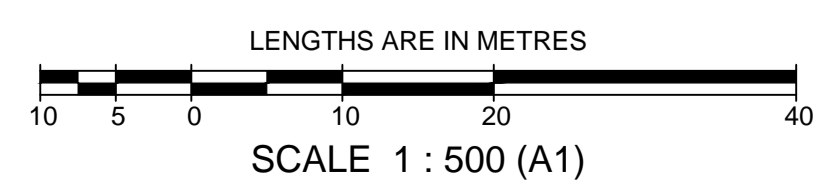

PRELIMINARY LEVELS TO BE ADJUSTED DURING THE DETAILED DESIGN PHASE ONCE MW DRAINAGE SCHEME AND OVERLAND FLOWS HAVE BEEN APPROVED.

**WARNING**  
BEWARE OF UNDERGROUND SERVICES  
THE LOCATION OF UNDERGROUND SERVICES ARE APPROXIMATE ONLY AND THEIR EXACT POSITION SHOULD BE PROVEN ON SITE. NO GUARANTEE IS GIVEN THAT ALL EXISTING SERVICES ARE SHOWN.

**NOTE:**  
KERB CUTOFF FOR PASSIVE IRRIGATION. REFER TO DETAIL ON SHEET 5. FINAL STREET PIT LOCATION TO BE COORDINATED WITH LANDSCAPE DRAWINGS.

- ATTENTION TO CONTRACTOR**
- IT IS THE CONTRACTORS RESPONSIBILITY TO ENSURE THAT THE DIGITAL PLAN, PROVIDED FOR SETOUT PURPOSES, MATCHES THE TBM CO-ORDINATES SHOWN.
  - WHERE CONCRETE WORKS ABOUT A SEWER ACCESS CHAMBER SURROUND OR SIMILAR STRUCTURE, AN EXPANSION JOINT OF APPROVAL MATERIAL SHALL BE PROVIDED BETWEEN THE TWO FACES.
  - CONTRACTOR TO ENSURE THAT THE SITE IS PEGGED AND OR SET OUT CHECKED BY THE LICENCED SURVEYOR RESPONSIBLE FOR CERTIFYING THE PLAN OF SUBDIVISION PRIOR TO UNDERGROUND INFRASTRUCTURE BEING INSTALLED.

PRELIMINARY

		1/19 cato street hawthorn east, 3123 telephone 8823 2300 fax no. 8823 2310								
MELWAY REF.	356-C-1	<b>ASPIRE ESTATE STAGE 31 LAYOUT PLAN SHEET 2 OF 2</b>								
SURVEY	BPD									
DESIGN	J.B									
DRAWN	I.W	SCALE	AS SHOWN	DATUM	AHD	DATE	NOV '21	SHEET	02 OF 34	P1

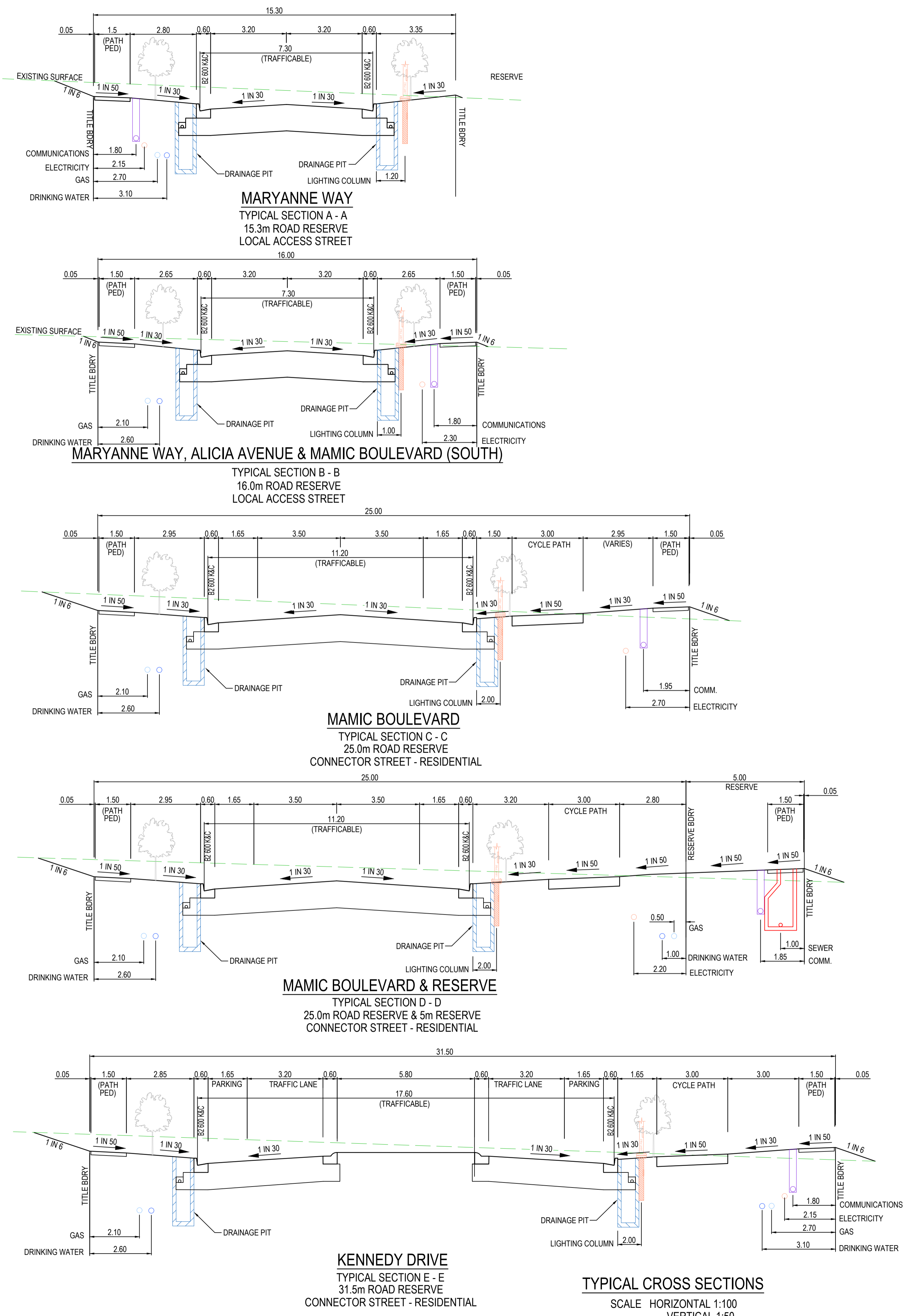

**TYPICAL CROSS SECTIONS**  
SCALE HORIZONTAL 1:100  
VERTICAL 1:50

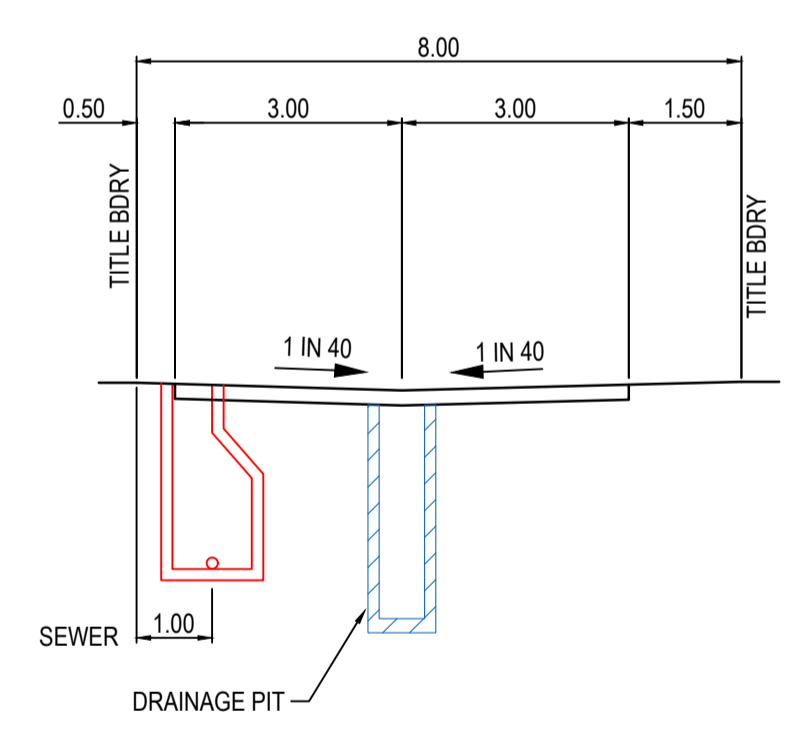
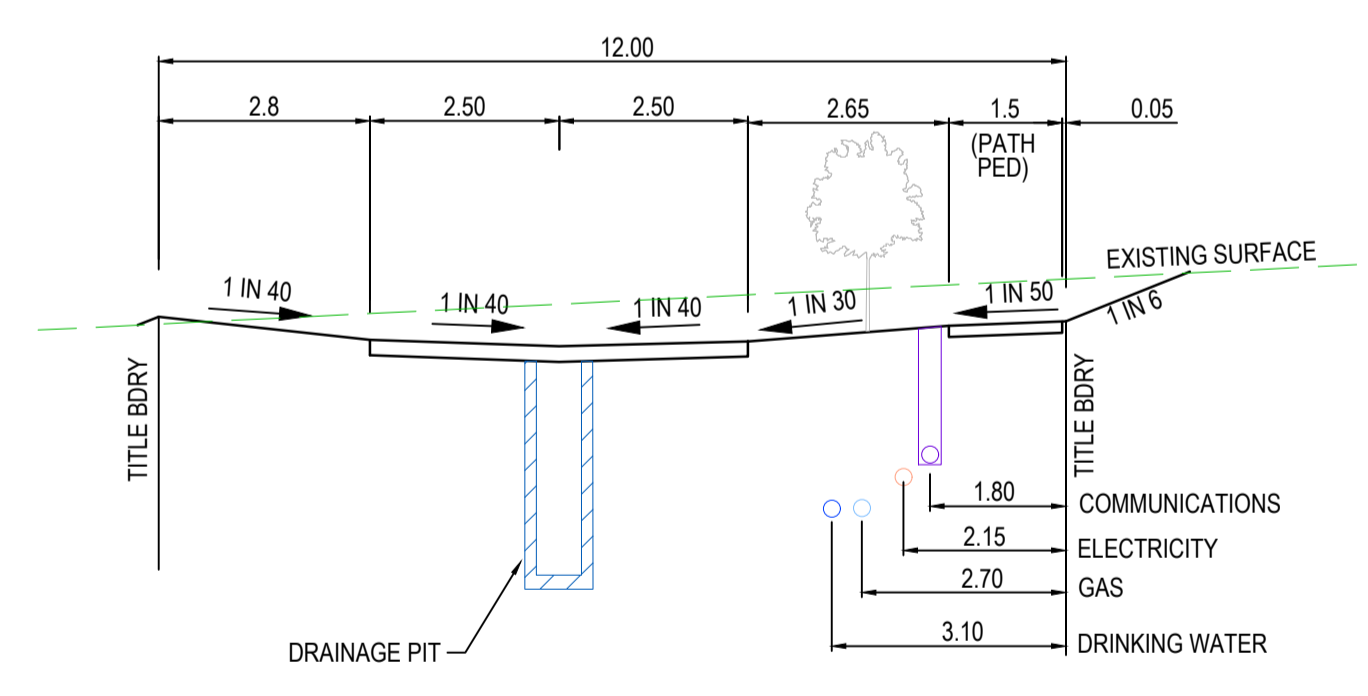

AMENDMENTS		 <b>breese pitt dixon pty. ltd.</b> land surveyors      civil engineers		1/19 cato street hawthorn east, 3123 telephone 8823 2300 fax no. 8823 2310				
				MELWAY REF. 356-C-1	<b>ASPIRE ESTATE</b> <b>STAGE 31</b> <b>TYPICAL CROSS SECTIONS</b>		MUNICIPALITY <b>MELTON</b>	
				SURVEY BPD			REFERENCE 8226 E/31	
				DESIGN J.B				
VER	DATE	REMARKS	CHECKED -	SCALE AS SHOWN	DATUM AHD	DATE NOV '21	SHEET 03 OF 34	P1