

ENLARGEMENT AT ACCESS OPENING

ACCESS OPENING DETAIL

Not to Scale



NOTE:

1. COLUMN TO BE HOT DIPPED GALVANIZED
2. PAINT FINISH - REFER SPECIFICATION.

CONCRETE FOOTINGS :

FOUNDATIONS:
F1. IF BASE AT FOOTING EXCAVATIONS BECOMES WET PRIOR TO POURING CONCRETE THEN THE WATER AND ANY SOFTENED MATERIAL SHALL BE REMOVED PRIOR TO POURING THE FOOTINGS.

CONCRETE:

C1. ALL CONCRETE SHALL BE VIBRATED.

C2. CONCRETE CRITERIA:
STRENGTH GRADE - 32 MPa
AGGREGATE SIZE (MAX.) - 20mm
NOMINAL SLUMP - 80mm

REINFORCEMENT SYMBOLS:

Y : HOT ROLLED DEFORMED BARS TO AS1302
F : FABRIC TO AS1304
R : STRUCTURAL GRADE PLAIN ROUND BAR TO AS1302
THE NUMBER FOLLOWING IS THE BAR DIAMETER IN mm.

C4. THE ELECTRICAL CONTRACTOR SHALL SUPPLY ALL NECESSARY BAR CHAIRS (PLASTIC TIPPED), SUPPORT AND SPACER BARS, AND CONCRETE BLOCKS FOR FOOTING AND SLAB REINFORCEMENT, TO PLACE STEEL IN ITS CORRECT POSITION DURING CONCRETING.

C5. COVER TO REINFORCEMENT:
75mm ALL ROUND (RIBLOC CAISSON INCLUDED).

C6. LAPS:
BARS TO BE LAPPED 28 BAR DIAMETERS U.N.O.
FABRIC TO BE LAPPED 400mm

C7. CONCRETE SHALL BE CURED FOR A MINIMUM OF 7 DAYS.

C8. ENSURE THAT SIDES OF EXCAVATION ARE SUCH THAT SOIL DOES NOT FALL IN DURING PLACEMENT OF CONCRETE.

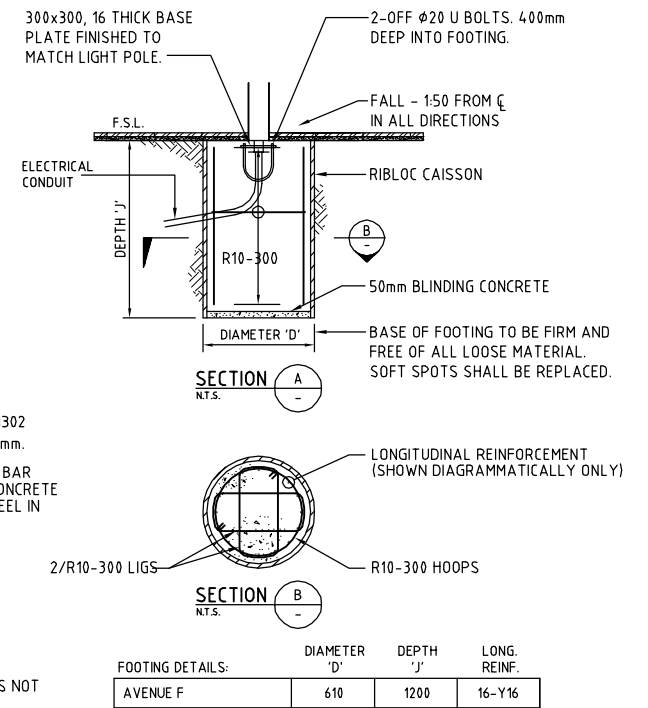

TYPICAL FOOTING DETAIL

Not to Scale

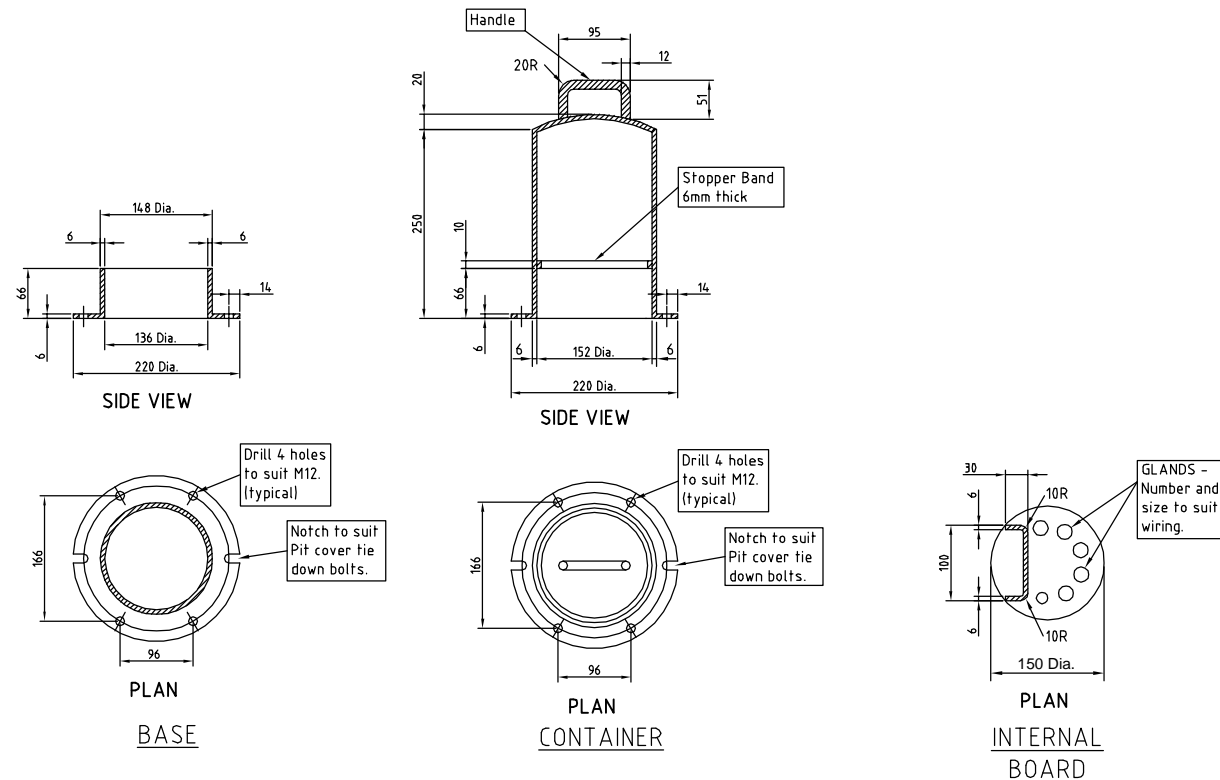
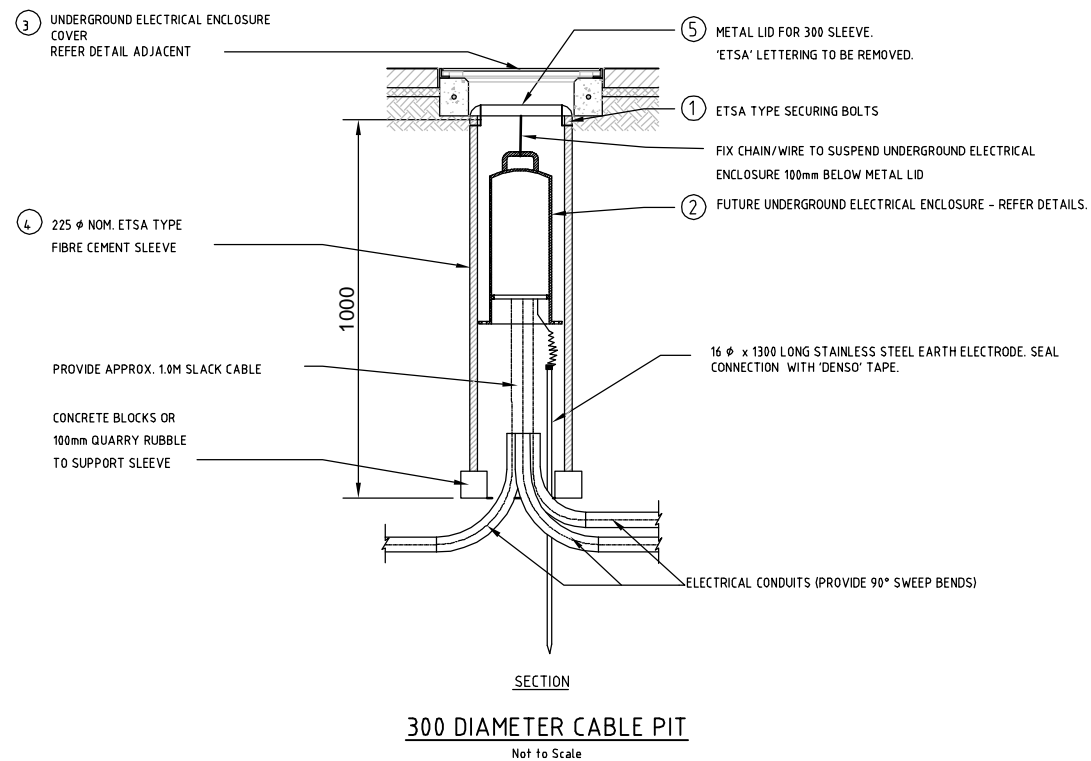

DETAILS OF UNDERGROUND ELECTRICAL ENCLOSURE

Not to Scale



WARNING
ALL SERVICES SHOWN ON THIS DRAWING ARE APPROXIMATE ONLY AND EXACT LOCATION IS TO BE CONFIRMED ON SITE BY CONTRACTOR PRIOR TO COMMENCEMENT OF ANY WORKS.

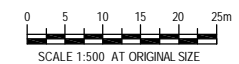

PRELIMINARY

No	Revision	Note: * indicates signatures on original issue of drawing or last revision of drawing	Drawn	Job Manager	Project Director	Date
A	ISSUED FOR REVIEW		RW			



DO NOT SCALE

Conditions of Use.
This document may only be used by GHD's client (and any other person who GHD has agreed can use this document) for the purpose for which it was prepared and must not be used by any other person or for any other purpose.

Drawn	G.CATER	Designer	G.CATER
Drafting Check		Design Check	
Approved (Project Director)			
Date			
Scale	AS SHOWN	This Drawing must not be used for Construction unless signed as Approved	

Client	VILLAWOOD PROPERTIES
Project	ASPIRE
Title	STAGE 2 - LANDSCAPE LINEAR PARK LIGHTING DETAILS

Original Size
A1 Drawing No: 31-26332-L215

Rev: A