

# RATHDOWNE ESTATE

450 CRAIGIEBURN ROAD , WOLLERT, VICTORIA

## STAGE 31 LANDSCAPE CONTRACT: RAT-31-SS LANDSCAPE WORKS

CLIENT: VILLAWOOD

ISSUE FOR: **COUNCIL APPROVAL**

DATE: **AUGUST 2024**

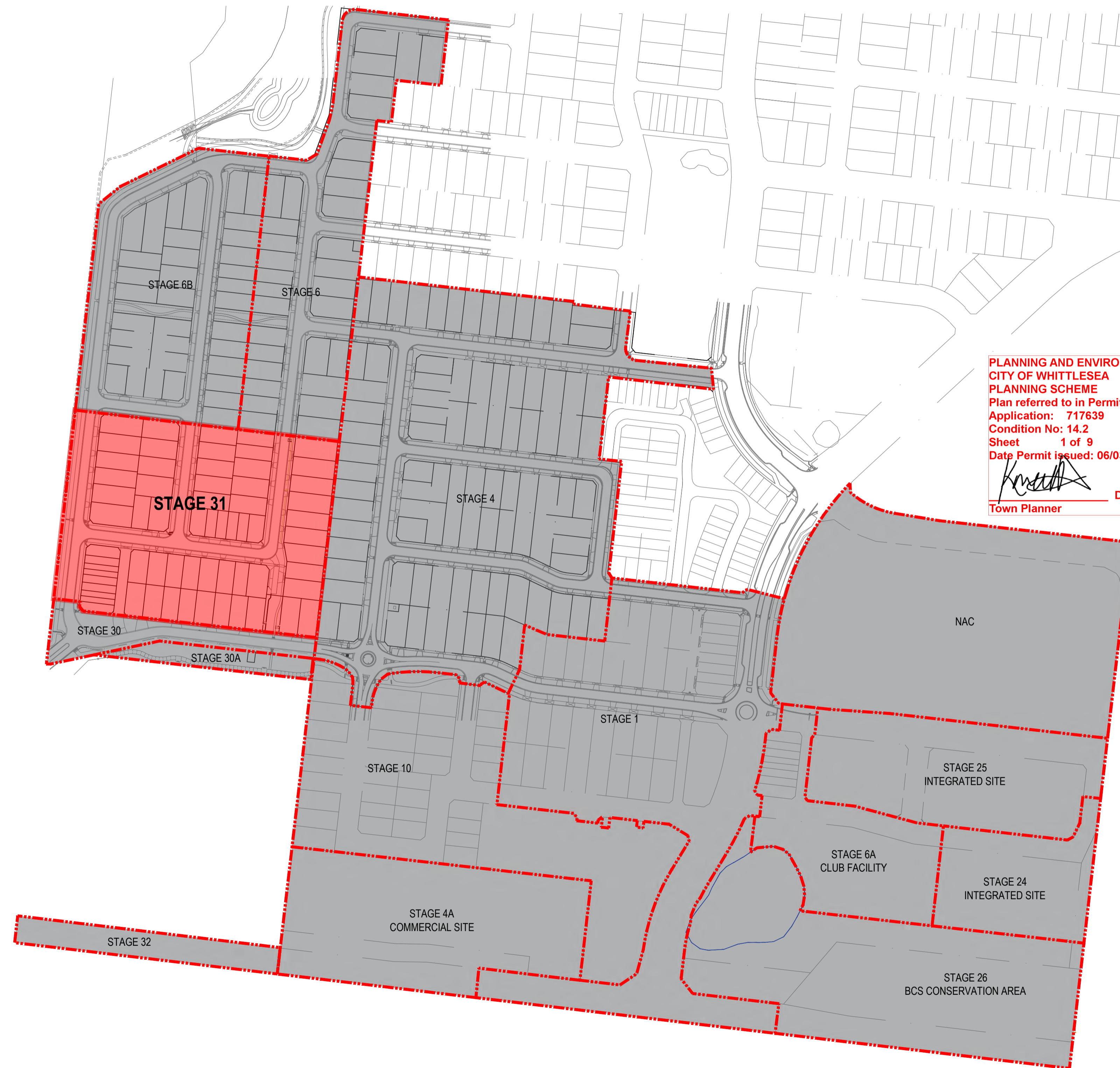

PLANNING AND ENVIRONMENT ACT  
CITY OF WHITTLESEA  
PLANNING SCHEME  
Plan referred to in Permit to use and/or develop land.  
Application: 717639  
Condition No: 14.2  
Sheet 1 of 9  
Date Permit issued: 06/03/2019  
*[Signature]*  
Town Planner Date: 22/08/2024

### Sheet List Table

SHEET	REVISION	SHEET TITLE
RAT-S31-SS-000	H	COVER
RAT-S31-SS-001	H	OVERALL PLAN
RAT-S31-SS-500	H	PLANTING PLAN 1
RAT-S31-SS-501	H	PLANTING PLAN 2
RAT-S31-SS-502	H	PLANTING PLAN 3
RAT-S31-SS-503	H	PLANTING PLAN 4
RAT-S31-SS-920	H	FENCES AND GATES DETAILS
RAT-S31-SS-970	H	SOFTWORKS DETAILS
RAT-S31-SS-971	H	STREET TREE SECTION

### STREET TREE LAYOUT PREPARED BASED ON:

REFERENCE DRAWING	DATE	VERSION
<b>CIVIL:</b> S985-31-E-R&D.dwg Strees Plat Dixon Pty. Ltd. (BPD) 1 Cato Street Harrhorn East, VIC 3123 03 8823 2300	Aug 2023	A
<b>ELECTRICAL:</b> VES-0351066-001.dwg Plan B - Services Building 20, 270 Ferntree Gully Rd. Nothing Hill, VIC 3168 (03) 9501 2055	Mar 2024	1.0
<b>TELECOMMUNICATION:</b> RATH-0031_Rev1.dwg OPTICOMM	FEB 2024	1.0

LOCATION PLAN  
1:2000 @ A1

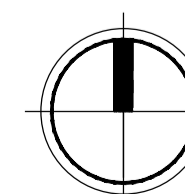

PRELIMINARY  
NOT FOR CONSTRUCTION  
INFORMATION ONLY



*[Signature]*  
 Town Planner  
 Date: 22/08/2024

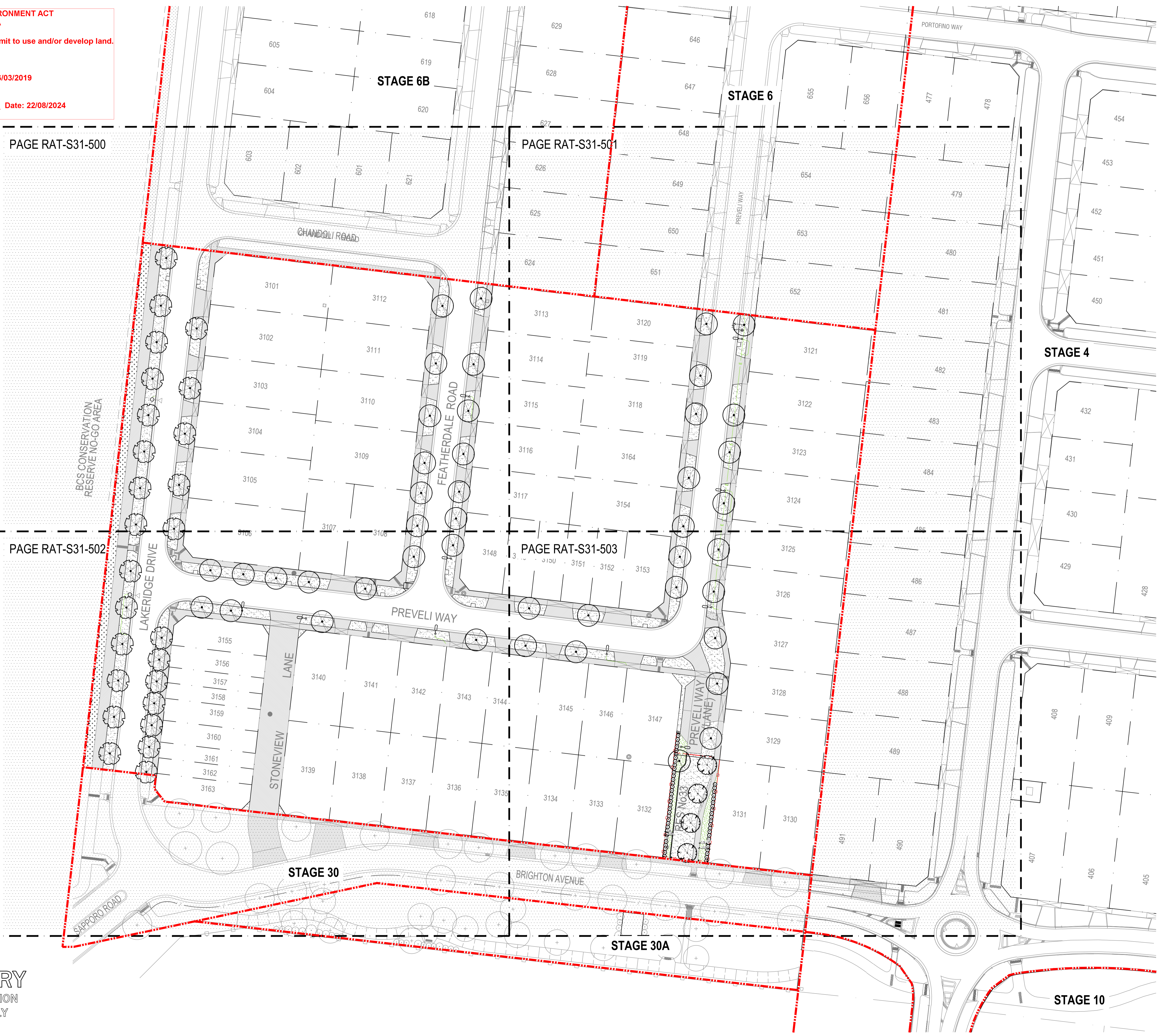

**PRELIMINARY**  
 NOT FOR CONSTRUCTION  
 INFORMATION ONLY

**STANDARD NOTES**

- SET OUT & DIMENSIONS.** THE CONTRACTOR SHALL SET OUT ALL PITS, WALLS, HARD SURFACES AND ELEMENTS EITHER ON OR OFF SITE PRIOR TO CONSTRUCTION AND SHALL OBTAIN THE SUPERINTENDENT'S SET OUT APPROVAL PRIOR TO WORKS COMMENCING. WRITTEN DIMENSIONS SHALL TAKE PRECEDENCE OVER SCALE. CHECK ALL DRAWING SCALES IN CONJUNCTION WITH DRAWING SIZE.
- SERVICES & SITE ASSETS.** THE CONTRACTOR SHALL INVESTIGATE THE NATURE AND LOCATION OF ALL EXISTING SERVICES AND FITTED SITE ASSETS AFFECTED BY THEIR WORKS. FAILURE TO TAKE DUE CARE SHALL NOT LIMIT THE CONTRACTOR'S LIABILITIES.
- REFERENCE.** THE CONTRACTOR SHALL REFER TO ALL CONTRACT DOCUMENTS, THE SPECIFICATION AND DRAWINGS PRIOR TO AND DURING THE WORKS.
- DISCREPANCIES.** NOTIFY SUPERINTENDENT OF ANY SUSPECTED DISCREPANCIES OR ERRORS PRIOR TO THE ORDERING OF AFFECTED MATERIALS AND OR CONSTRUCTION OF AFFECTED WORKS.
- RELEVANT STANDARDS.** THE CONTRACTOR SHALL UNDERTAKE ALL FINISHING AND WORKS IN ACCORDANCE WITH CURRENT INDUSTRY BEST PRACTICE AND ALL RELEVANT AUSTRALIAN STANDARDS.
- SERVICE LOCATOR.** THE CONTRACTOR SHALL UNDERTAKE A DIAL BEFORE YOU DIG PROCESS PRIOR TO COMMENCING WORKS ON SITE. THE CONTRACTOR SHALL ENGAGE A SERVICE LOCATOR TO MAP THE SPECIFIC LOCATIONS AND DEPTHS OF ALL SERVICES AND ADVISE ALL RELEVANT STAFF AND SUBCONTRACTORS IN WRITING PRIOR TO COMMENCING WORKS ON SITE.

REV	DATE	BY	ISSUE OR AMENDMENT
H	01/08/2024	SR	ISSUED FOR COUNCIL APPROVAL
G	24/05/2024	SR	ISSUED FOR COUNCIL APPROVAL
F	10/05/2024	SR	ISSUED FOR COUNCIL APPROVAL
E	05/04/2023	SR	ISSUED FOR COUNCIL APPROVAL
D	28/08/2023	SR	ISSUED FOR COUNCIL REVIEW
C	16/03/2023	SR	ISSUED FOR ELECTRICAL COORDINATION
B	16/02/2023	SR	ISSUED FOR CLIENT COORDINATION
A	24/01/2023	SR	ISSUED FOR CLIENT COORDINATION

THIS IS AN UNCONTROLLED DOCUMENT ISSUED FOR INFORMATION ONLY UNLESS SHOWN BELOW AT EACH RELEVANT STAGE.

INTERNAL DESIGN REVIEW  
 THE DESIGN IS NOT AUTHORIZED FOR TENDER WITHOUT BEING INTERNALLY REVIEWED AND ENDORSED HERE.

INTERNAL PRETENDER REVIEW  
 THIS DRAWING IS NOT AUTHORIZED FOR TENDER WITHOUT BEING INTERNALLY REVIEWED AND ENDORSED HERE.

AUTHORISED FOR CONSTRUCTION  
 THIS DRAWING IS NOT AUTHORIZED FOR CONSTRUCTION UNLESS IT IS MARKED REV 1 OR HIGHER AND IS SIGNED HERE.

**emerge ASSOCIATES**  
 Integrated Science & Design  
 PERTH (08) 9380 4988 • MARGARET RIVER (08) 9758 8159

PROJECT  
**RATHDOWNE ESTATE**  
 450 CRAIGIEBURN ROAD, WOLLERT, VICTORIA  
 STAGE OR PHASE  
**STAGE 31**

DRAWING TITLE  
**OVERALL PLAN**

CLIENT  
**VILLAWOOD**

DESIGNED BY **SR** PRELIM DESIGN REVIEWED BY **SLC**  
 DRAWN BY **SR** PRELIM DWG REVIEWED BY **SLC**  
 DATE INITIALLY DRAWN **20/01/2023**  
 SCALE **1: 500 @ A1** METRES  
 DRAWING NUMBER **RAT-S31-SS-001** REV **H**

PLANNING AND ENVIRONMENT ACT  
 CITY OF WHITTLESEA  
 PLANNING SCHEME  
 Plan referred to in Permit to use and/or develop land.  
 Application: 717639  
 Condition No: 14.2  
 Sheet 3 of 9  
 Date Permit issued: 06/03/2019  
 Date: 22/08/2024  
 Town Planner

**LEGEND**

- EXTENT OF WORKS
- TURF
- HYDROSEED TURF
- Melia azedarach 'Elite'
- Quercus palustris
- FN-01 BOLLARD WITH CABLE
- GAS PIPE
- NON-DRINKABLE WATER
- DRINKABLE WATER
- SEWER DRAINAGE
- ELECTRIC POWER
- COMMUNICATION OPTICAL
- STORMWATER DRAIN PITS
- STREET LAMP POST
- CONCRETE FOOTPATH & CROSSOVER BY CIVIL

**STANDARD NOTES**

- SET OUT & DIMENSIONS.** THE CONTRACTOR SHALL SET OUT ALL PATHS, WALLS, HARD SURFACES AND ELEMENTS EITHER ON OR OFF SITE PRIOR TO CONSTRUCTION AND SHALL OBTAIN THE SUPERINTENDENT'S SET OUT APPROVAL PRIOR TO WORKS COMMENCING. WRITTEN DIMENSIONS SHALL TAKE PRECEDENCE OVER SCALE. CHECK ALL DRAWING SCALES IN CONJUNCTION WITH DRAWING SIZE.
- SERVICES & SITE ASSETS.** THE CONTRACTOR SHALL INVESTIGATE THE NATURE AND LOCATION OF ALL EXISTING SERVICES AND SITE ASSETS AFFECTED BY THEIR WORKS. FAILURE TO TAKE DUE CARE SHALL NOT LIMIT THE CONTRACTOR'S LIABILITIES.
- REFERENCE.** THE CONTRACTOR SHALL REFER TO ALL CONTRACT DOCUMENTS, THE SPECIFICATION AND DRAWINGS PRIOR TO AND DURING THE WORKS.
- DISCREPANCIES.** NOTIFY SUPERINTENDENT OF ANY SUSPECTED DISCREPANCIES OR ERRORS PRIOR TO THE ORDERING OF AFFECTED MATERIALS AND OR CONSTRUCTION OF AFFECTED WORKS.
- RELEVANT STANDARDS.** THE CONTRACTOR SHALL UNDERTAKE ALL PRICES AND WORKS IN ACCORDANCE WITH CURRENT AUSTRALIAN INDUSTRY BEST PRACTICE AND ALL RELEVANT AUSTRALIAN STANDARDS.
- SERVICE LOCATOR.** THE CONTRACTOR SHALL UNDERTAKE A DIAL BEFORE YOU DIG PROCESS PRIOR TO COMMENCING WORKS ON SITE. THE CONTRACTOR SHALL ENGAGE A SERVICE LOCATOR TO MAP THE SPECIFIC LOCATIONS AND DEPTHS OF ALL SERVICES AND ADVISE ALL RELEVANT STAFF AND SUBCONTRACTORS IN WRITING PRIOR TO COMMENCING WORKS ON SITE.

REV	DATE	BY	ISSUE OR AMENDMENT
H	01/08/2024	SR	ISSUED FOR COUNCIL APPROVAL
G	24/05/2024	SR	ISSUED FOR COUNCIL APPROVAL
F	10/05/2024	SR	ISSUED FOR COUNCIL APPROVAL
E	05/04/2023	SR	ISSUED FOR COUNCIL APPROVAL
D	28/08/2023	SR	ISSUED FOR COUNCIL REVIEW
C	16/03/2023	SR	ISSUED FOR ELECTRICAL COORDINATION
B	16/02/2023	SR	ISSUED FOR CLIENT COORDINATION
A	24/01/2023	SR	ISSUED FOR CLIENT COORDINATION

THIS IS AN UNCONTROLLED DOCUMENT ISSUED FOR INFORMATION ONLY UNLESS SIGNED BELOW AT EACH RELEVANT STAGE.

INTERNAL DESIGN REVIEW  
 THE DESIGN IS NOT AUTHORIZED FOR TENDER WITHOUT BEING INTERNALLY REVIEWED AND SIGNED HERE. EMERGE DIRECTOR DATE

INTERNAL PRETENDER REVIEW  
 THE DRAWING IS NOT AUTHORIZED FOR TENDER WITHOUT BEING INTERNALLY REVIEWED AND SIGNED HERE. EMERGE DIRECTOR DATE

AUTHORISED FOR CONSTRUCTION  
 THE DRAWING IS NOT AUTHORIZED FOR CONSTRUCTION UNLESS IT IS MARKED REV 1 OR HIGHER AND IS SIGNED HERE. EMERGE DIRECTOR DATE

**emerge ASSOCIATES**  
 Integrated Science & Design  
 PERTH (08) 9380 4988 • MARGARET RIVER (08) 9758 8159

PROJECT  
 RATHDOWNE ESTATE  
 450 CRAIGIEBURN ROAD, WOLLERT, VICTORIA  
 STAGE OR PHASE  
 STAGE 31

DRAWING TITLE  
 PLANTING PLAN 1

CLIENT  
 VILLAWOOD

DESIGNED BY SR PRELIM DESIGN REVIEWED BY SLC  
 DRAWN BY SR PRELIM DWG REVIEWED BY SLC  
 DATE INITIALLY DRAWN 20/01/2023  
 SCALE 1: 200 @ A1 METRES  
 DRAWING NUMBER RAT-S31-SS-500 REV H

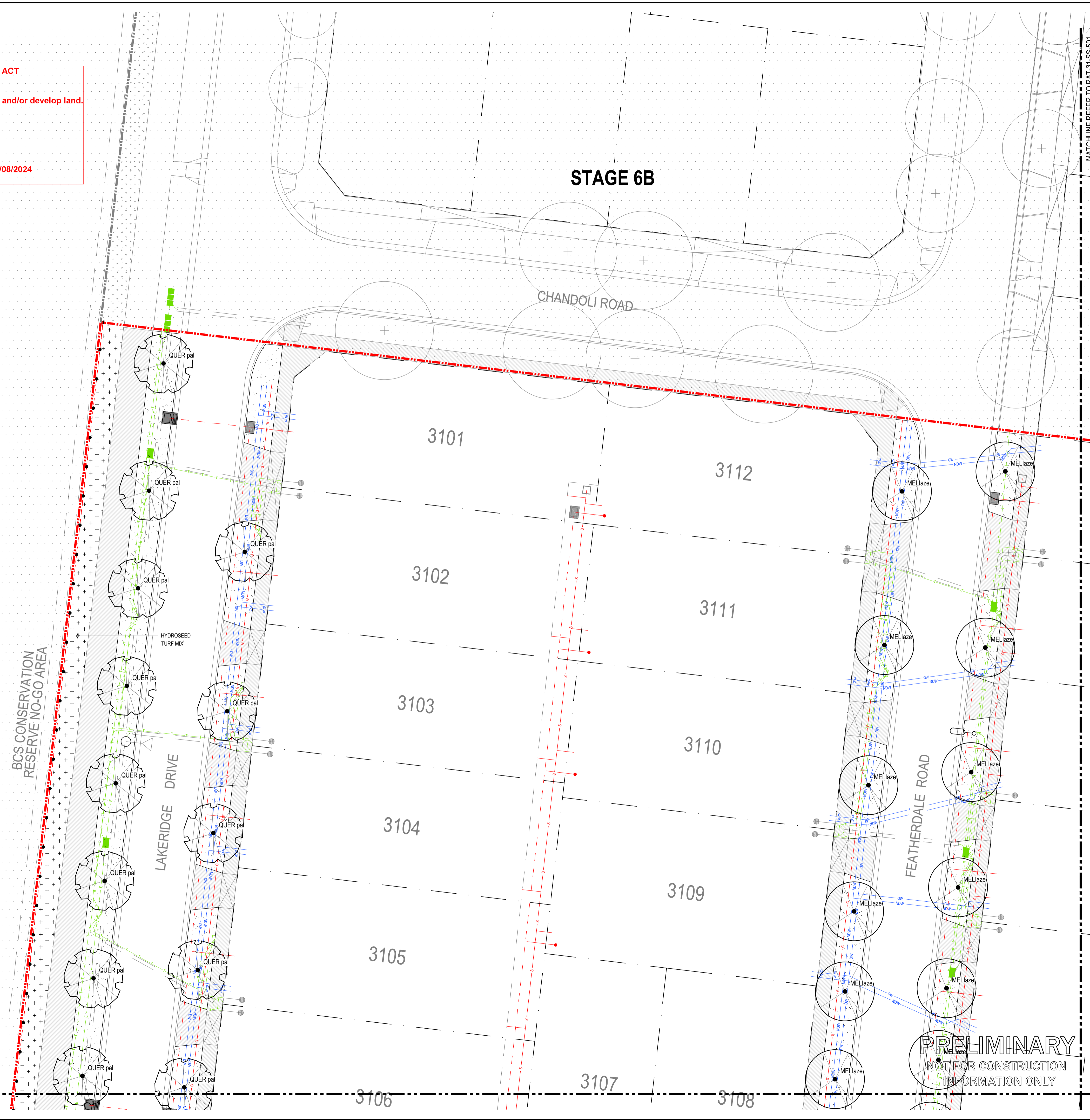

MATCHLINE REFER TO RAT-31-SS-502

MATCHLINE REFER TO RAT-31-SS-501

**PRELIMINARY**  
 NOT FOR CONSTRUCTION  
 INFORMATION ONLY

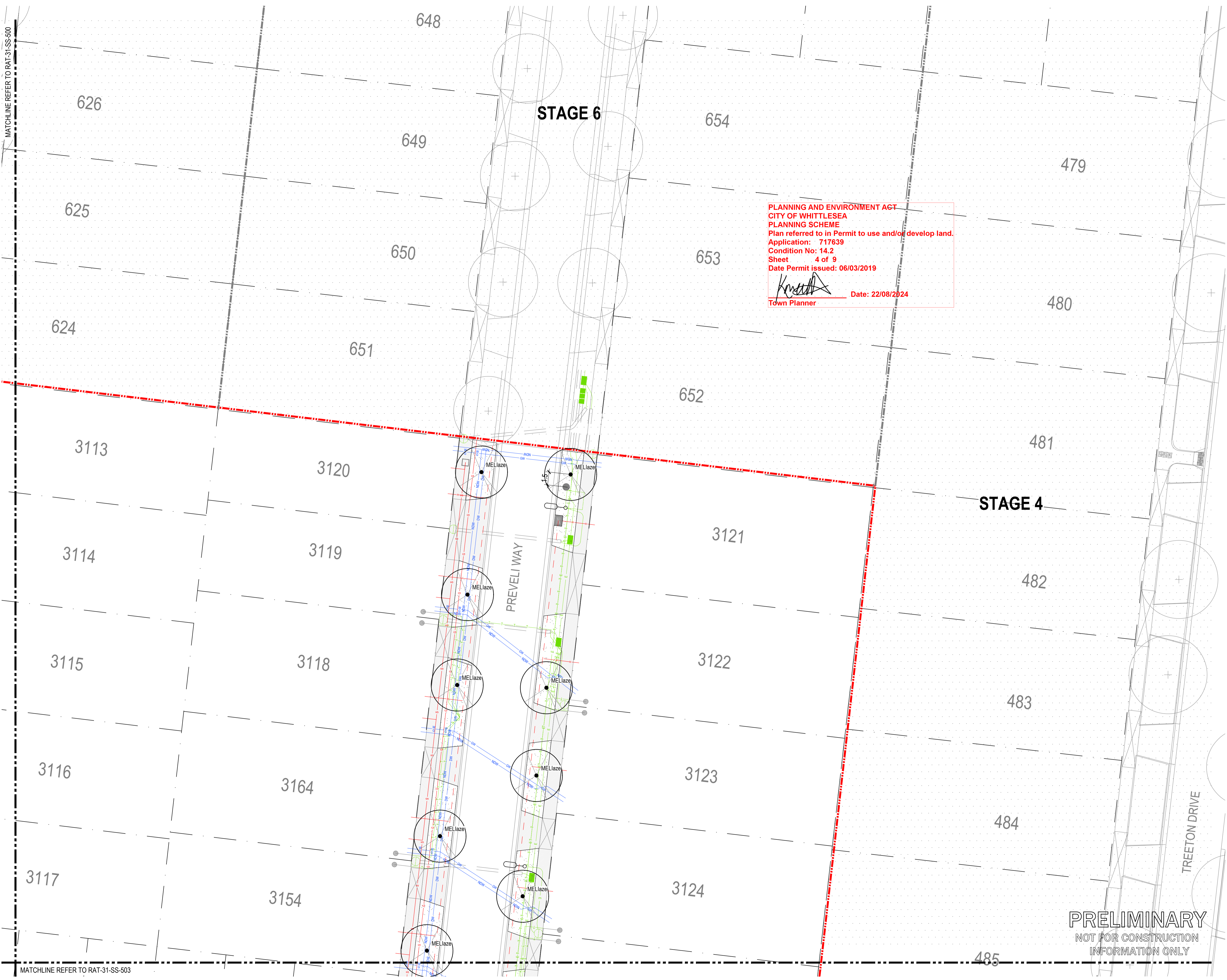

PLANNING AND ENVIRONMENT AGT  
 CITY OF WHITTLESEA  
 PLANNING SCHEME  
 Plan referred to in Permit to use and/or develop land.  
 Application: 717639  
 Condition No: 14.2  
 Sheet 4 of 9  
 Date Permit issued: 06/03/2019  
*[Signature]*  
 Town Planner Date: 22/08/2024

**LEGEND**

- - - - - EXTENT OF WORKS
- TURF
- Melia azedarach 'Elite'
- GAS PIPE
- NON-DRINKABLE WATER
- DRINKABLE WATER
- SEWER DRAINAGE
- ELECTRIC POWER
- COMMUNICATION OPTICAL
- STORMWATER DRAIN PIT
- STREET LAMP POST
- CONCRETE FOOTPATH & CROSSOVER BY CIVIL

- STANDARD NOTES**
1. **SET OUT & DIMENSIONS.** THE CONTRACTOR SHALL SET OUT ALL PITS, WALLS, CURBS, SURFACES AND ELEMENTS EITHER ON OR OFF SITE PRIOR TO CONSTRUCTION AND SHALL OBTAIN THE SUPERINTENDENT'S SET OUT APPROVAL PRIOR TO WORKS COMMENCING. WRITTEN DIMENSIONS SHALL TAKE PRECEDENCE OVER SCALE. CHECK ALL DRAWING SCALES IN CONJUNCTION WITH DRAWING SIZE.
  2. **SERVICES & SITE ASSETS.** THE CONTRACTOR SHALL INVESTIGATE THE NATURE AND LOCATION OF ALL EXISTING SERVICES AND SITE ASSETS AFFECTED BY THEIR WORKS. FAILURE TO TAKE DUE CARE SHALL NOT LIMIT THE CONTRACTOR'S LIABILITIES.
  3. **REFERENCE.** THE CONTRACTOR SHALL REFER TO ALL CONTRACT DOCUMENTS, THE SPECIFICATION AND DRAWINGS PRIOR TO AND DURING THE WORKS.
  4. **DISCREPANCIES.** NOTIFY SUPERINTENDENT OF ANY SUSPECTED DISCREPANCIES OR ERRORS PRIOR TO THE ORDERING OF AFFECTED MATERIALS AND OR CONSTRUCTION OF AFFECTED WORKS.
  5. **RELEVANT STANDARDS.** THE CONTRACTOR SHALL UNDERTAKE ALL PRICING AND WORKS IN ACCORDANCE WITH CURRENT INDUSTRY BEST PRACTICE AND ALL RELEVANT AUSTRALIAN STANDARDS.
  6. **SERVICE LOCATOR.** THE CONTRACTOR SHALL UNDERTAKE A DIAL BEFORE YOU DIG PROCESS PRIOR TO COMMENCING WORKS ON SITE. THE CONTRACTOR SHALL ENGAGE A SERVICE LOCATOR TO MAP THE SPECIFIC LOCATIONS AND DEPTHS OF ALL SERVICES AND ADVISE ALL RELEVANT STAFF AND SUBCONTRACTORS IN WRITING PRIOR TO COMMENCING WORKS ON SITE.

H	01/08/2024	SR	ISSUED FOR COUNCIL APPROVAL
G	24/05/2024	SR	ISSUED FOR COUNCIL APPROVAL
F	10/05/2024	SR	ISSUED FOR COUNCIL APPROVAL
E	05/04/2023	SR	ISSUED FOR COUNCIL APPROVAL
D	28/08/2023	SR	ISSUED FOR COUNCIL REVIEW
C	16/03/2023	SR	ISSUED FOR ELECTRICAL COORDINATION
B	16/02/2023	SR	ISSUED FOR CLIENT COORDINATION
A	24/01/2023	SR	ISSUED FOR CLIENT COORDINATION
REV	DATE	BY	ISSUE OR AMENDMENT

THIS IS AN UNCONTROLLED DOCUMENT ISSUED FOR INFORMATION ONLY UNLESS SIGNED BELOW AT EACH RELEVANT STAGE.

**INTERNAL DESIGN REVIEW**  
 THIS DESIGN HAS BEEN REVIEWED BY: \_\_\_\_\_ DATE: \_\_\_\_\_  
 WITHOUT BEING INTERNALLY REVIEWED AND SIGNED HERE: \_\_\_\_\_

**INTERNAL PRETENDER REVIEW**  
 THIS DRAWING IS NOT AUTHORISED FOR TENDER WITHOUT BEING INTERNALLY REVIEWED AND SIGNED HERE: \_\_\_\_\_

**AUTHORISED FOR CONSTRUCTION**  
 THIS DRAWING IS NOT AUTHORISED FOR CONSTRUCTION UNLESS IT IS MARKED REV 1 OR HIGHER AND IS SIGNED HERE: \_\_\_\_\_

**emerge ASSOCIATES**  
 Integrated Science & Design  
 PERTH (08) 9380 4988 • MARGARET RIVER (08) 9758 8159

PROJECT  
 RATHDOWNE ESTATE  
 450 CRAIGIEBURN ROAD, WOLLERT, VICTORIA  
 STAGE OR PHASE  
 STAGE 31

DRAWING TITLE  
 PLANTING PLAN 2

CLIENT  
 VILLAWOOD

DESIGNED BY SR PRELIM DESIGN REVIEWED BY SLC  
 DRAWN BY SR PRELIM DWG REVIEWED BY SLC  
 DATE INITIALLY DRAWN 20/01/2023  
 SCALE 1:200 @ A1 METRES  
 DRAWING NUMBER RAT-S31-SS-501 REV H

**PRELIMINARY**  
 NOT FOR CONSTRUCTION  
 INFORMATION ONLY

MATCHLINE REFER TO RAT-31-SS-500

MATCHLINE REFER TO RAT-31-SS-503

REF: M:\MANUSCRIPTS\PROJECTS\2023\08\31\STAGE 31\DRAWING\PLANTING\PLANTING PLAN 2\SS-503.DWG

PLANNING AND ENVIRONMENT ACT  
 CITY OF WHITTLESEA  
 PLANNING SCHEME  
 Plan referred to in Permit to use and/or develop land.  
 Application: 717639  
 Condition No: 14.2  
 Sheet 5 of 9  
 Date Permit issued: 06/03/2019  
 Date: 22/08/2024  
 Town Planner

BCS CONSERVATION RESERVE NO-GO AREA

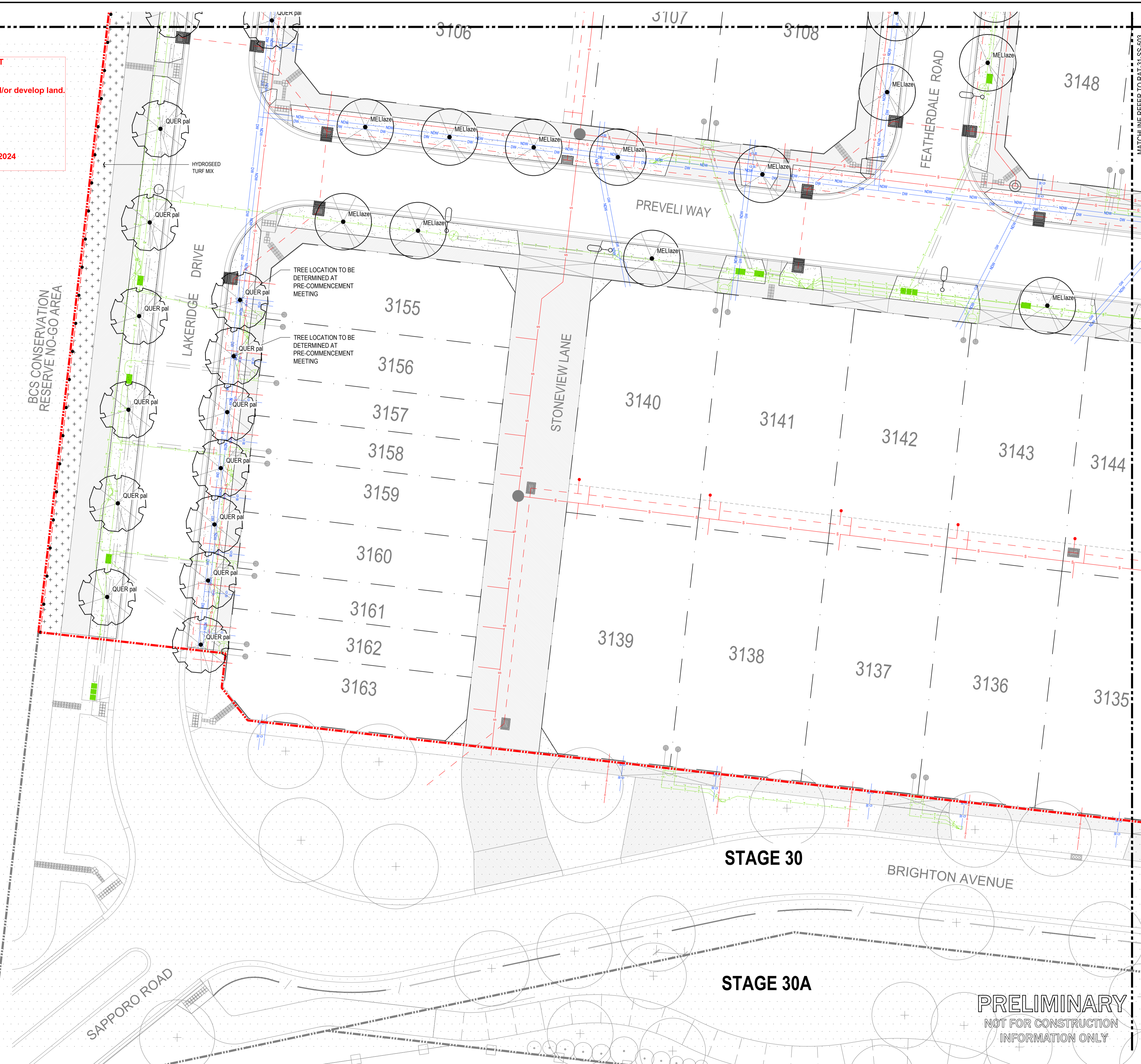

**LEGEND**

- EXTENT OF WORKS
- TURF
- HYDROSEED TURF
- Melia azedarach 'Elite'
- Quercus palustris
- FN-01 BOLLARD WITH CABLE
- GAS PIPE
- NON-DRINKABLE WATER
- DRINKABLE WATER
- SEWER DRAINAGE
- ELECTRIC POWER
- COMMUNICATION OPTICAL
- STORMWATER DRAIN PITS
- STREET LAMP POST
- CONCRETE FOOTPATH & CROSSOVER BY CIVIL

**STANDARD NOTES**

- SET OUT & DIMENSIONS.** THE CONTRACTOR SHALL SET OUT ALL PITS, WALLS, HANDS, SERVICES AND ELEMENTS EITHER ON OR OFF SITE PRIOR TO CONSTRUCTION AND SHALL OBTAIN THE SUPERINTENDENT'S SET OUT APPROVAL PRIOR TO WORKS COMMENCING. WRITTEN DIMENSIONS SHALL TAKE PRECEDENCE OVER SCALE. CHECK ALL DRAWING SCALES IN CONSULTATION WITH DRAWING SIZE.
- SERVICES & SITE ASSETS.** THE CONTRACTOR SHALL INVESTIGATE THE NATURE AND LOCATION OF ALL EXISTING SERVICES AND SET FENCED SITE ASSETS AFFECTED BY THEIR WORKS. FAILURE TO TAKE DUE CARE SHALL NOT LIMIT THE CONTRACTOR'S LIABILITIES.
- REFERENCE.** THE CONTRACTOR SHALL REFER TO ALL CONTRACT DOCUMENTS, THE SPECIFICATION AND DRAWINGS PRIOR TO AND DURING THE WORKS.
- DISCREPANCIES.** NOTIFY SUPERINTENDENT OF ANY SUSPECTED OR KNOWN DISCREPANCIES OR ERRORS PRIOR TO THE ORDERING OF AFFECTED MATERIALS AND OR CONSTRUCTION OF AFFECTED WORKS.
- RELEVANT STANDARDS.** THE CONTRACTOR SHALL UNDERTAKE ALL PRICING AND WORKS IN ACCORDANCE WITH CURRENT INDUSTRY BEST PRACTICE AND ALL RELEVANT AUSTRALIAN STANDARDS.
- SERVICE LOCATOR.** THE CONTRACTOR SHALL UNDERTAKE A DIAL BEFORE YOU DIG PROCESS PRIOR TO COMMENCING WORKS ON SITE. THE CONTRACTOR SHALL ENGAGE A SERVICE LOCATOR TO MAP THE SPECIFIC LOCATIONS AND DEPTHS OF ALL SERVICES AND ADVISE ALL RELEVANT STAFF AND SUBCONTRACTORS IN WRITING PRIOR TO COMMENCING WORKS ON SITE.

REV	DATE	BY	ISSUE OR AMENDMENT
H	01/08/2024	SR	ISSUED FOR COUNCIL APPROVAL
G	24/05/2024	SR	ISSUED FOR COUNCIL APPROVAL
F	10/05/2024	SR	ISSUED FOR COUNCIL APPROVAL
E	05/04/2023	SR	ISSUED FOR COUNCIL APPROVAL
D	28/08/2023	SR	ISSUED FOR COUNCIL REVIEW
C	16/03/2023	SR	ISSUED FOR ELECTRICAL COORDINATION
B	16/02/2023	SR	ISSUED FOR CLIENT COORDINATION
A	24/01/2023	SR	ISSUED FOR CLIENT COORDINATION

THIS IS AN UNCONTROLLED DOCUMENT ISSUED FOR INFORMATION ONLY UNLESS SIGNED BELOW AT EACH RELEVANT STAGE.

**INTERNAL DESIGN REVIEW**  
 THE DESIGN IS NOT APPROVED WITHOUT BEING INTERNALLY REVIEWED AND SIGNED HERE. EMERGE DIRECTOR: \_\_\_\_\_ DATE: \_\_\_\_\_

**INTERNAL PRETENDER REVIEW**  
 THE DRAWING IS NOT AUTHORISED FOR TENDER WITHOUT BEING INTERNALLY REVIEWED AND SIGNED HERE. EMERGE DIRECTOR: \_\_\_\_\_ DATE: \_\_\_\_\_

**AUTHORISED FOR CONSTRUCTION**  
 THE DRAWING IS NOT AUTHORISED FOR CONSTRUCTION UNLESS IT IS MARKED REV 1 OR HIGHER AND IS SIGNED HERE. EMERGE DIRECTOR: \_\_\_\_\_ DATE: \_\_\_\_\_

**emerge ASSOCIATES**  
 Integrated Science & Design  
 PERTH (08) 9380 4988 • MARGARET RIVER (08) 9758 8159

PROJECT  
 RATHDOWNE ESTATE  
 450 CRAIGIEBURN ROAD, WOLLERT, VICTORIA  
 STAGE OR PHASE  
 STAGE 31

DRAWING TITLE  
 PLANTING PLAN 3

CLIENT  
 VILLAWOOD

DESIGNED BY SR PRELIM DESIGN REVIEWED BY SLG  
 DRAWN BY SR PRELIM DWG REVIEWED BY SLG  
 DATE INITIALLY DRAWN 20/10/2023  
 SCALE 1: 200 @ A1 METRES  
 DRAWING NUMBER RAT-S31-SS-502 REV H

STAGE 30

STAGE 30A

**PRELIMINARY**  
 NOT FOR CONSTRUCTION  
 INFORMATION ONLY

SEE MAINSCAPE VICTORIAN PROJECTS/2023/08/RATHDOWNE ESTATE/450 CRAIGIEBURN ROAD/STAGE 31/SS-500

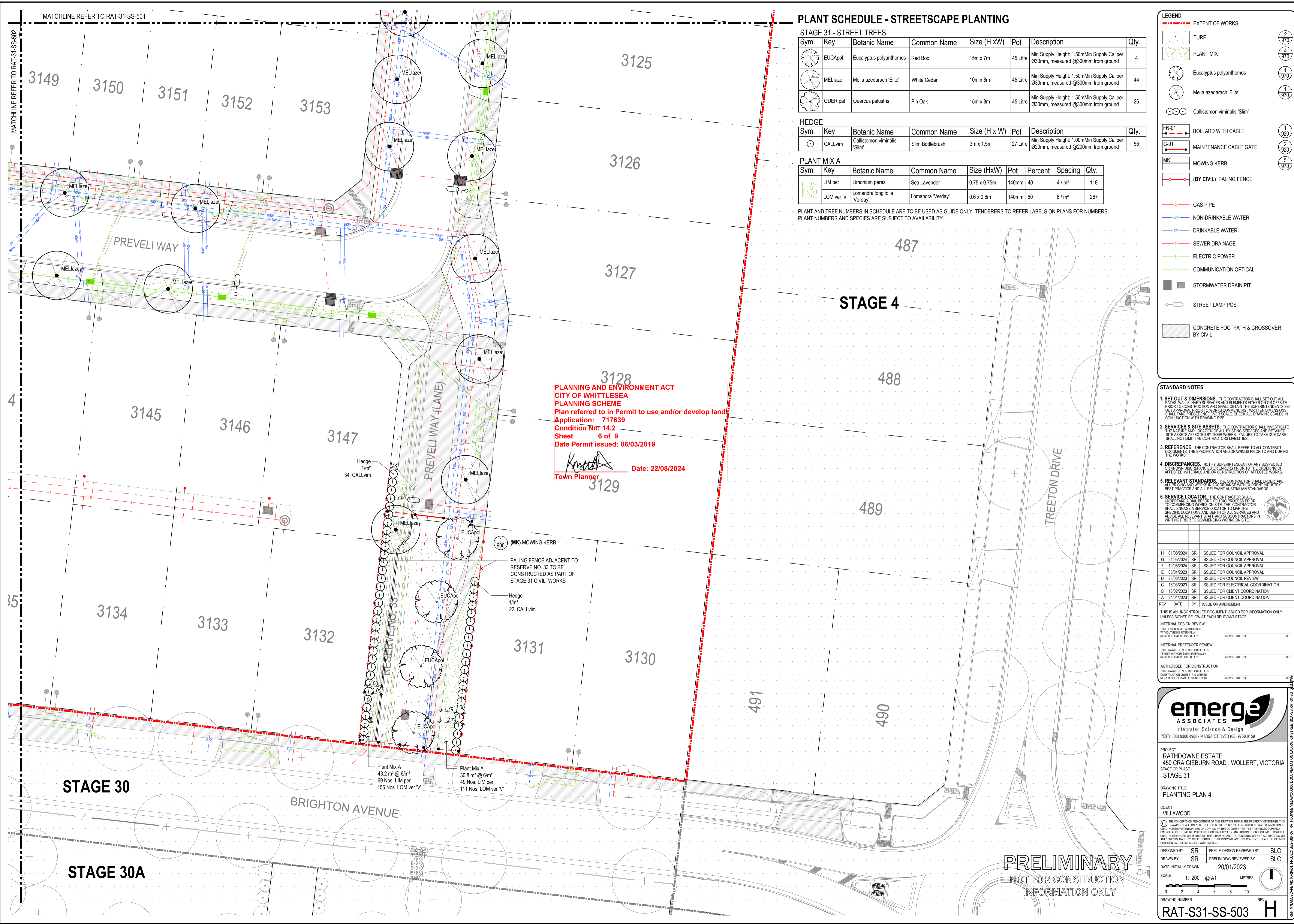

**PLANT SCHEDULE - STREETScape PLANTING**

**STAGE 31 - STREET TREES**

Sym.	Key	Botanic Name	Common Name	Size (H x W)	Pot	Description	Qty.
	EUCApol	Eucalyptus polyanthemos	Red Box	15m x 7m	45 Litre	Min Supply Height: 1.50m Min Supply Caliper Ø30mm, measured @300mm from ground	4
	MELlaze	Melia azedarach 'Elite'	White Cedar	10m x 8m	45 Litre	Min Supply Height: 1.50m Min Supply Caliper Ø30mm, measured @300mm from ground	44
	QUERpal	Quercus palustris	Pin Oak	15m x 8m	45 Litre	Min Supply Height: 1.50m Min Supply Caliper Ø30mm, measured @300mm from ground	26

**HEDGE**

Sym.	Key	Botanic Name	Common Name	Size (H x W)	Pot	Description	Qty.
	CALLvim	Callistemon viminalis 'Slim'	Slim Bottlebrush	3m x 1.5m	27 Litre	Min Supply Height: 1.00m Min Supply Caliper Ø20mm, measured @200mm from ground	56

**PLANT MIX A**

Sym.	Key	Botanic Name	Common Name	Size (HxW)	Pot	Percent	Spacing	Qty.
	LIM per	Limonium perezii	Sea Lavender	0.75 x 0.75m	140mm	40	4 / m <sup>2</sup>	118
	LOM ver 'V'	Lomandra longifolia 'Verday'	Lomandra 'Verday'	0.6 x 0.6m	140mm	60	6 / m <sup>2</sup>	267

PLANT AND TREE NUMBERS IN SCHEDULE ARE TO BE USED AS GUIDE ONLY. TENDERERS TO REFER LABELS ON PLANS FOR NUMBERS. PLANT NUMBERS AND SPECIES ARE SUBJECT TO AVAILABILITY.

**LEGEND**

- EXTENT OF WORKS
- TURF
- PLANT MIX
- Eucalyptus polyanthemos
- Melia azedarach 'Elite'
- Callistemon viminalis 'Slim'
- FN-01 BOLLARD WITH CABLE
- G-01 MAINTENANCE CABLE GATE
- MK MOWING KERB
- (BY CIVIL) PALING FENCE
- GAS PIPE
- NON-DRINKABLE WATER
- DRINKABLE WATER
- SEWER DRAINAGE
- ELECTRIC POWER
- COMMUNICATION OPTICAL
- STORMWATER DRAIN PIT
- STREET LAMP POST
- CONCRETE FOOTPATH & CROSSOVER BY CIVIL

- STANDARD NOTES**
- SET OUT & DIMENSIONS.** THE CONTRACTOR SHALL SET OUT ALL PITS, WALLS, HAND RAILS, SERVICES AND ELEMENTS EITHER ON OR OFF SITE PRIOR TO CONSTRUCTION AND SHALL OBTAIN THE SUPERINTENDENT'S SET OUT APPROVAL PRIOR TO WORKS COMMENCING. WRITTEN DIMENSIONS SHALL TAKE PRECEDENCE OVER SCALE. CHECK ALL DRAWING SCALES IN CONJUNCTION WITH DRAWING SIZE.
  - SERVICES & SITE ASSETS.** THE CONTRACTOR SHALL INVESTIGATE THE NATURE AND LOCATION OF ALL EXISTING SERVICES AND SET ASSETS AFFECTED BY THEIR WORKS. FAILURE TO TAKE DUE CARE SHALL NOT LIMIT THE CONTRACTOR'S LIABILITIES.
  - REFERENCE.** THE CONTRACTOR SHALL REFER TO ALL CONTRACT DOCUMENTS, THE SPECIFICATION AND DRAWINGS PRIOR TO AND DURING THE WORKS.
  - DISCREPANCIES.** NOTIFY SUPERINTENDENT OF ANY SUSPECTED DISCREPANCIES OR ERRORS PRIOR TO THE ORDERING OF AFFECTED MATERIALS AND OR CONSTRUCTION OF AFFECTED WORKS.
  - RELEVANT STANDARDS.** THE CONTRACTOR SHALL UNDERTAKE ALL PRICES AND WORKS IN ACCORDANCE WITH CURRENT INDUSTRY BEST PRACTICE AND ALL RELEVANT AUSTRALIAN STANDARDS.
  - SERVICE LOCATOR.** THE CONTRACTOR SHALL UNDERTAKE A DIAL BEFORE YOU DIG PROCESS PRIOR TO COMMENCING WORKS ON SITE. THE CONTRACTOR SHALL ENGAGE A SERVICE LOCATOR TO MAP THE SPECIFIC LOCATIONS AND DEPTHS OF ALL SERVICES AND ADVISE ALL RELEVANT STAFF AND SUBCONTRACTORS IN WRITING PRIOR TO COMMENCING WORKS ON SITE.

REV	DATE	BY	ISSUE OR AMENDMENT
H	01/08/2024	SR	ISSUED FOR COUNCIL APPROVAL
G	24/05/2024	SR	ISSUED FOR COUNCIL APPROVAL
F	10/05/2024	SR	ISSUED FOR COUNCIL APPROVAL
E	05/04/2023	SR	ISSUED FOR COUNCIL APPROVAL
D	28/08/2023	SR	ISSUED FOR COUNCIL REVIEW
C	16/03/2023	SR	ISSUED FOR ELECTRICAL COORDINATION
B	16/02/2023	SR	ISSUED FOR CLIENT COORDINATION
A	24/01/2023	SR	ISSUED FOR CLIENT COORDINATION

THIS IS AN UNCONTROLLED DOCUMENT ISSUED FOR INFORMATION ONLY UNLESS SIGNED BELOW AT EACH RELEVANT STAGE.

INTERNAL DESIGN REVIEW  
THIS DESIGN IS NOT AUTHORISED FOR TENDER WITHOUT BEING INTERNALLY REVIEWED AND SIGNED HERE.

INTERNAL PRETENDER REVIEW  
THIS DRAWING IS NOT AUTHORISED FOR TENDER WITHOUT BEING INTERNALLY REVIEWED AND SIGNED HERE.

AUTHORISED FOR CONSTRUCTION  
THIS DRAWING IS NOT AUTHORISED FOR CONSTRUCTION UNLESS IT IS MARKED 'REV' OR 'H' AND IS SIGNED HERE.

**emerge ASSOCIATES**  
Integrated Science & Design  
PERTH (08) 9380 4988 • MARGARET RIVER (08) 9758 8159

PROJECT  
RATHDOWNE ESTATE  
450 CRAIGIEBURN ROAD, WOLLERT, VICTORIA  
STAGE OR PHASE  
STAGE 31

DRAWING TITLE  
PLANTING PLAN 4

CLIENT  
VILLAWOOD

DESIGNED BY SR PRELIM DESIGN REVIEWED BY SLC  
DRAWN BY SR PRELIM DWG REVIEWED BY SLC  
DATE INITIALLY DRAWN 20/01/2023  
SCALE 1:200 @ A1 METRES  
DRAWING NUMBER RAT-SS31-SS-503 REV H

**PLANNING AND ENVIRONMENT ACT  
CITY OF WHITTLESEA  
PLANNING SCHEME**  
Plan referred to in Permit to use and/or develop land  
Application: 717639  
Condition No: 14.2  
Sheet 6 of 9  
Date Permit issued: 06/03/2019

*Kenneth* Date: 22/08/2024  
Town Planner

**PRELIMINARY**  
NOT FOR CONSTRUCTION  
INFORMATION ONLY

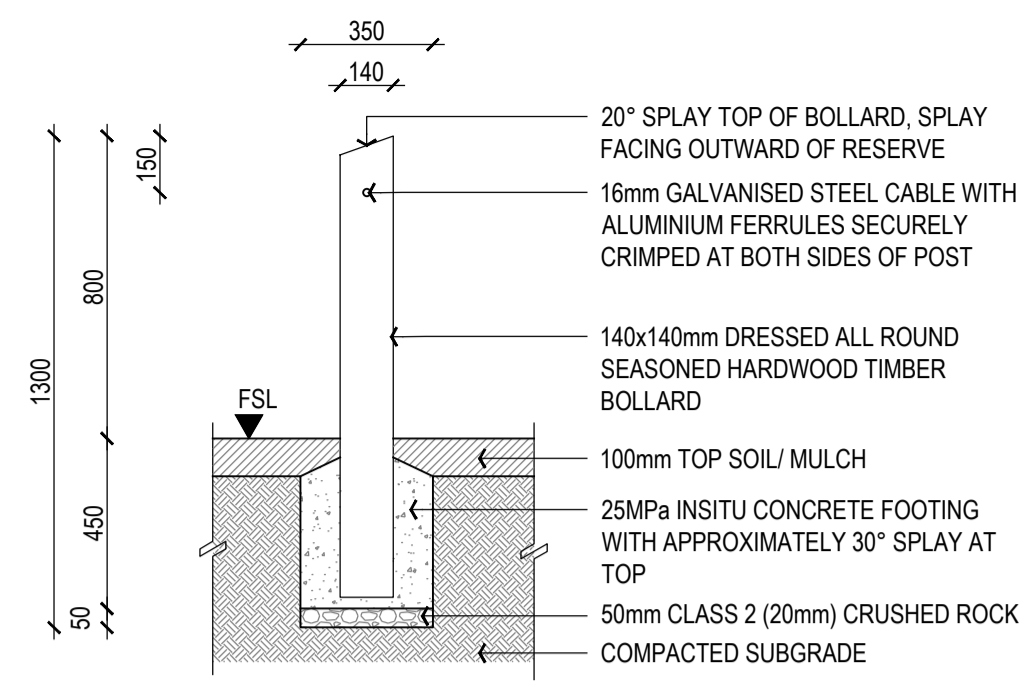
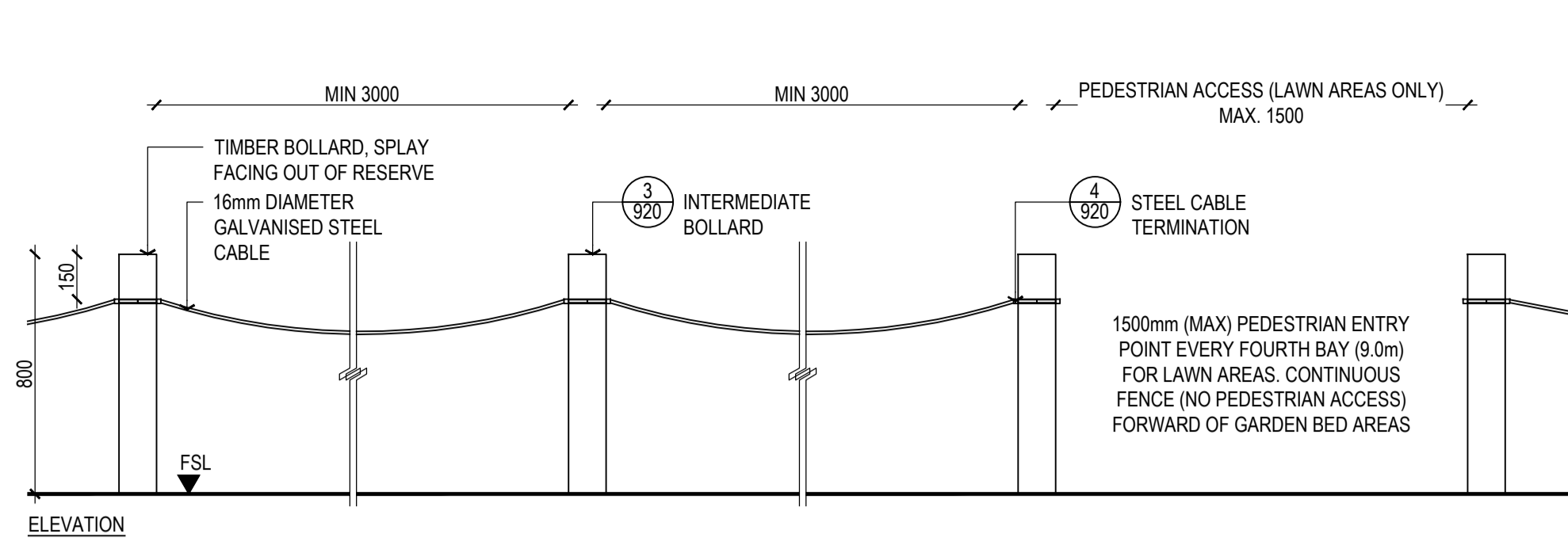

1 (FN-01) TIMBER BOLLARD AND CABLE FENCE (CITY OF WHITTLESEA TYPICAL DETAIL)  
SCALE 1:20

2 TIMBER BOLLARD (CITY OF WHITTLESEA TYPICAL DETAIL)  
SECTION SCALE 1:20

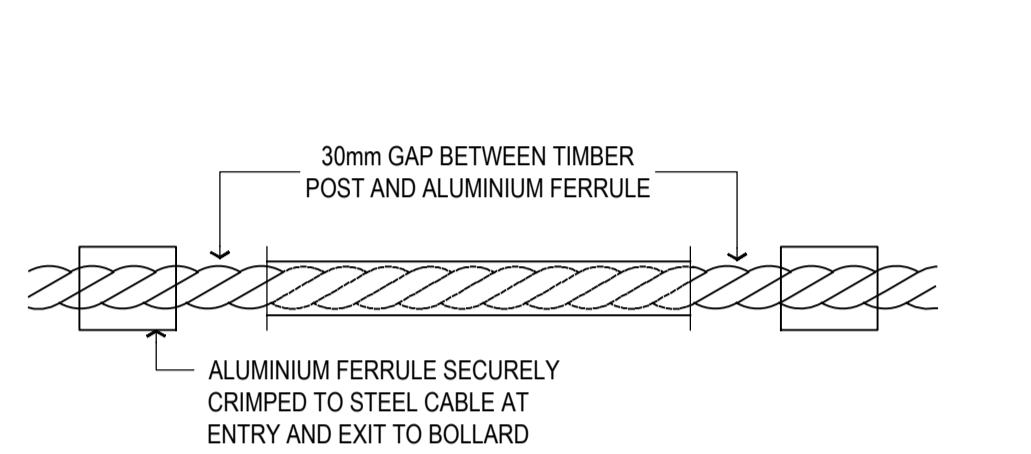

3 INTERMEDIATE BOLLARD FIXING  
SECTION SCALE 1:10

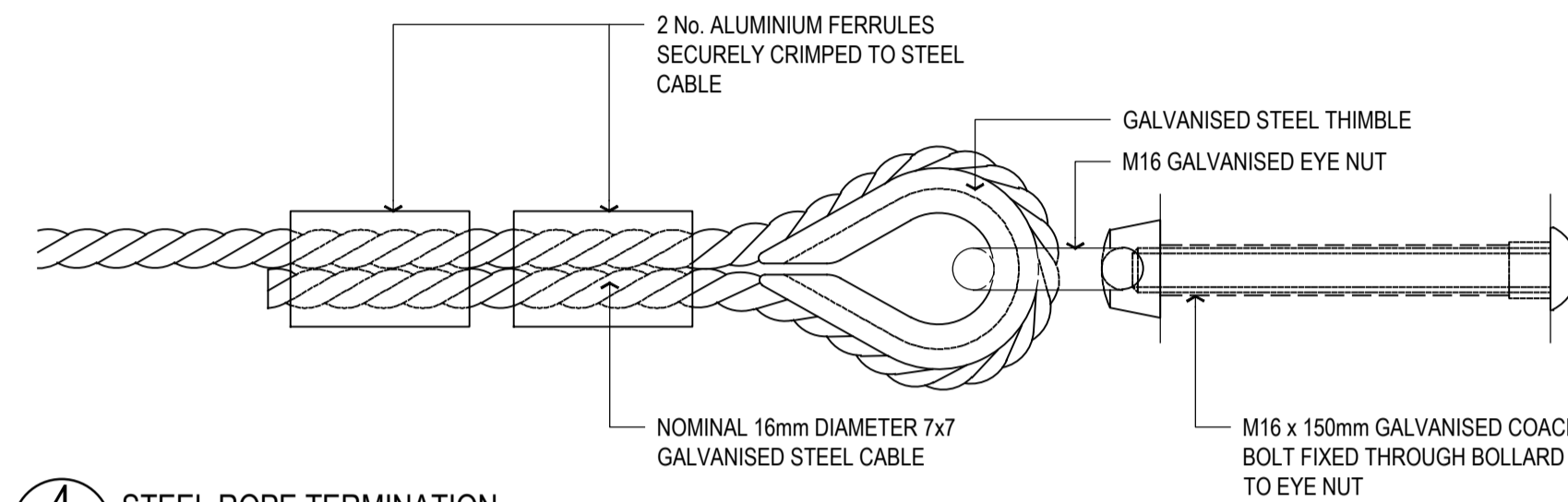

4 STEEL ROPE TERMINATION  
SECTION SCALE 1:10

**PLANNING AND ENVIRONMENT ACT  
CITY OF WHITTLESEA  
PLANNING SCHEME**  
Plan referred to in Permit to use and/or develop land.  
Application: 717639  
Condition No: 14.2  
Sheet 7 of 9  
Date Permit issued: 06/03/2019  
*[Signature]* Date: 22/08/2024  
Town Planner

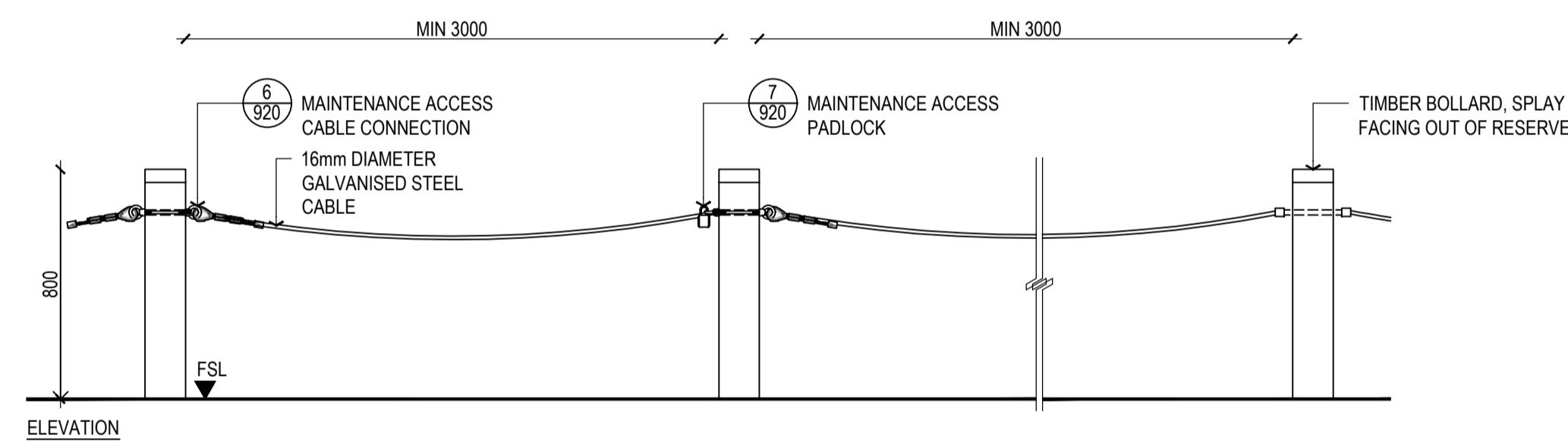

**NOTES**  
THE MAINTENANCE ACCESS GATE CABLE IS TO BE INDEPENDENT FROM VEHICLE EXCLUSION FENCE CABLE.

5 (G-01) POST AND CABLE MAINTENANCE GATE (CITY OF WHITTLESEA TYPICAL DETAIL)  
SCALE 1:20

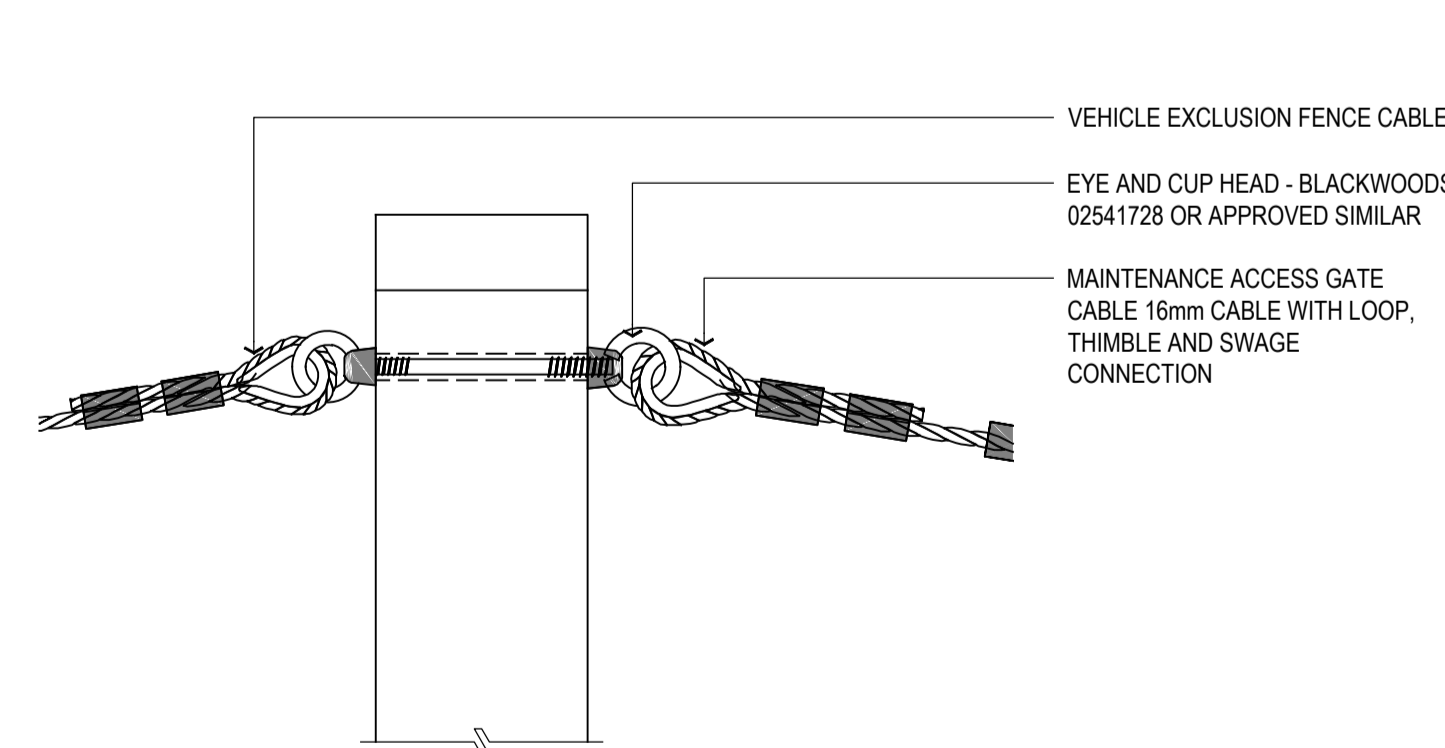

6 MAINTENANCE ACCESS CABLE CONNECTION  
SCALE 1:5

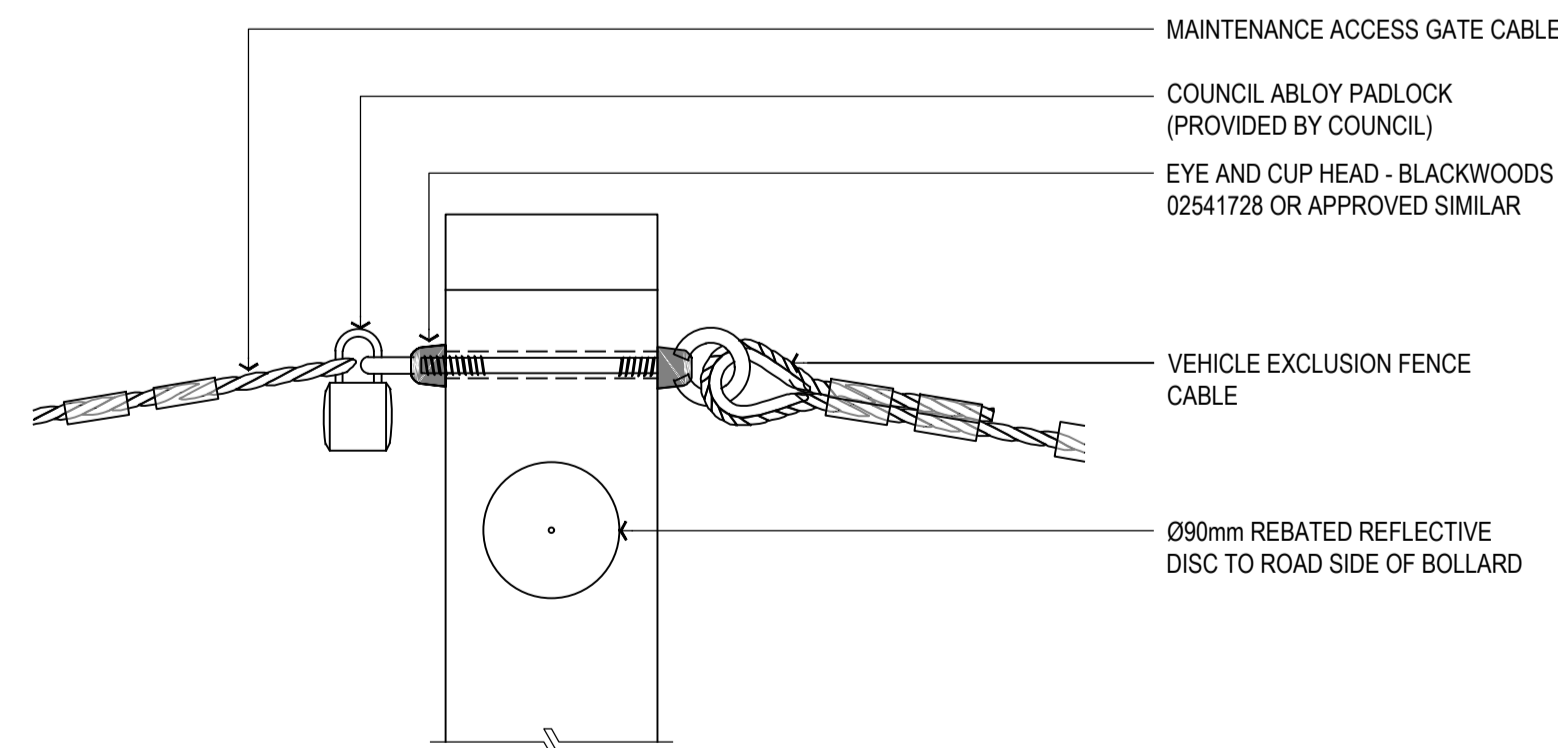

7 MAINTENANCE ACCESS PADLOCK  
SCALE 1:5

**PRELIMINARY**  
NOT FOR CONSTRUCTION  
INFORMATION ONLY

**STANDARD NOTES**

- SET OUT & DIMENSIONS.** THE CONTRACTOR SHALL SET OUT ALL PATHS, WALLS, HARD SURFACES AND ELEMENTS EITHER ON OR OFF SITE PRIOR TO CONSTRUCTION AND SHALL OBTAIN THE SUPERINTENDENT'S SET OUT APPROVAL PRIOR TO WORKS COMMENCING. WRITTEN DIMENSIONS SHALL TAKE PRECEDENCE OVER SCALE. CHECK ALL DRAWING SCALES IN CONJUNCTION WITH DRAWING SIZE.
- SERVICES & SITE ASSETS.** THE CONTRACTOR SHALL INVESTIGATE THE NATURE AND LOCATION OF ALL EXISTING SERVICES AND RETAINED SITE ASSETS AFFECTED BY THEIR WORKS. FAILURE TO TAKE DUE CARE SHALL NOT LIMIT THE CONTRACTOR'S LIABILITIES.
- REFERENCE.** THE CONTRACTOR SHALL REFER TO ALL CONTRACT DOCUMENTS, THE SPECIFICATION AND DRAWINGS PRIOR TO AND DURING THE WORKS.
- DISCREPANCIES.** NOTIFY SUPERINTENDENT OF ANY SUSPECTED DISCREPANCIES OR ERRORS PRIOR TO THE ORDERING OF AFFECTED MATERIALS AND OR CONSTRUCTION OF AFFECTED WORKS.
- RELEVANT STANDARDS.** THE CONTRACTOR SHALL UNDERTAKE ALL PRICING AND WORKS IN ACCORDANCE WITH CURRENT INDUSTRY BEST PRACTICE AND ALL RELEVANT AUSTRALIAN STANDARDS.
- SERVICE LOCATOR.** THE CONTRACTOR SHALL UNDERTAKE A DIAL BEFORE YOU DIG PROCESS PRIOR TO COMMENCING WORKS ON SITE. THE CONTRACTOR SHALL ENGAGE A SERVICE LOCATOR TO MAP THE SPECIFIC LOCATIONS AND DEPTHS OF ALL SERVICES AND ADVISE ALL RELEVANT STAFF AND SUBCONTRACTORS IN WRITING PRIOR TO COMMENCING WORKS ON SITE.

REV	DATE	BY	ISSUE OR AMENDMENT
H	01/08/2024	SR	ISSUED FOR COUNCIL APPROVAL
G	24/05/2024	SR	ISSUED FOR COUNCIL APPROVAL
F	10/05/2024	SR	ISSUED FOR COUNCIL APPROVAL
E	05/04/2023	SR	ISSUED FOR COUNCIL APPROVAL
D	28/08/2023	SR	ISSUED FOR COUNCIL REVIEW
C	16/03/2023	SR	ISSUED FOR ELECTRICAL COORDINATION
B	16/02/2023	SR	ISSUED FOR CLIENT COORDINATION
A	24/01/2023	SR	ISSUED FOR CLIENT COORDINATION

THIS IS AN UNCONTROLLED DOCUMENT ISSUED FOR INFORMATION ONLY UNLESS SIGNED BELOW AT EACH RELEVANT STAGE.

**INTERNAL DESIGN REVIEW**  
THIS DESIGN IS NOT AUTHORISED FOR TENDER WITHOUT BEING INTERNALLY REVIEWED AND SIGNED HERE: \_\_\_\_\_ EMERGE DIRECTOR \_\_\_\_\_ DATE \_\_\_\_\_

**INTERNAL PRETENDER REVIEW**  
THIS DRAWING IS NOT AUTHORISED FOR TENDER WITHOUT BEING INTERNALLY REVIEWED AND SIGNED HERE: \_\_\_\_\_ EMERGE DIRECTOR \_\_\_\_\_ DATE \_\_\_\_\_

**AUTHORISED FOR CONSTRUCTION**  
THIS DRAWING IS NOT AUTHORISED FOR CONSTRUCTION UNLESS IT IS MARKED 'REV 1' OR HIGHER AND IS SIGNED HERE: \_\_\_\_\_ EMERGE DIRECTOR \_\_\_\_\_ DATE \_\_\_\_\_

**emerge ASSOCIATES**  
Integrated Science & Design  
PERTH (08) 9380 4988 • MARGARET RIVER (08) 9758 8159

PROJECT  
RATHDOWNE ESTATE  
450 CRAIGIEBURN ROAD, WOLLERT, VICTORIA  
STAGE OR PHASE  
STAGE 31

DRAWING TITLE  
FENCES AND GATES DETAILS

CLIENT  
VILLAWOOD

DESIGNED BY SR PRELIM DESIGN REVIEWED BY SLC  
DRAWN BY SR PRELIM DWG REVIEWED BY SLC  
DATE INITIALLY DRAWN 20/01/2023  
SCALE AS SHOWN  
DRAWING NUMBER RAT-S31-SS-920 REV H

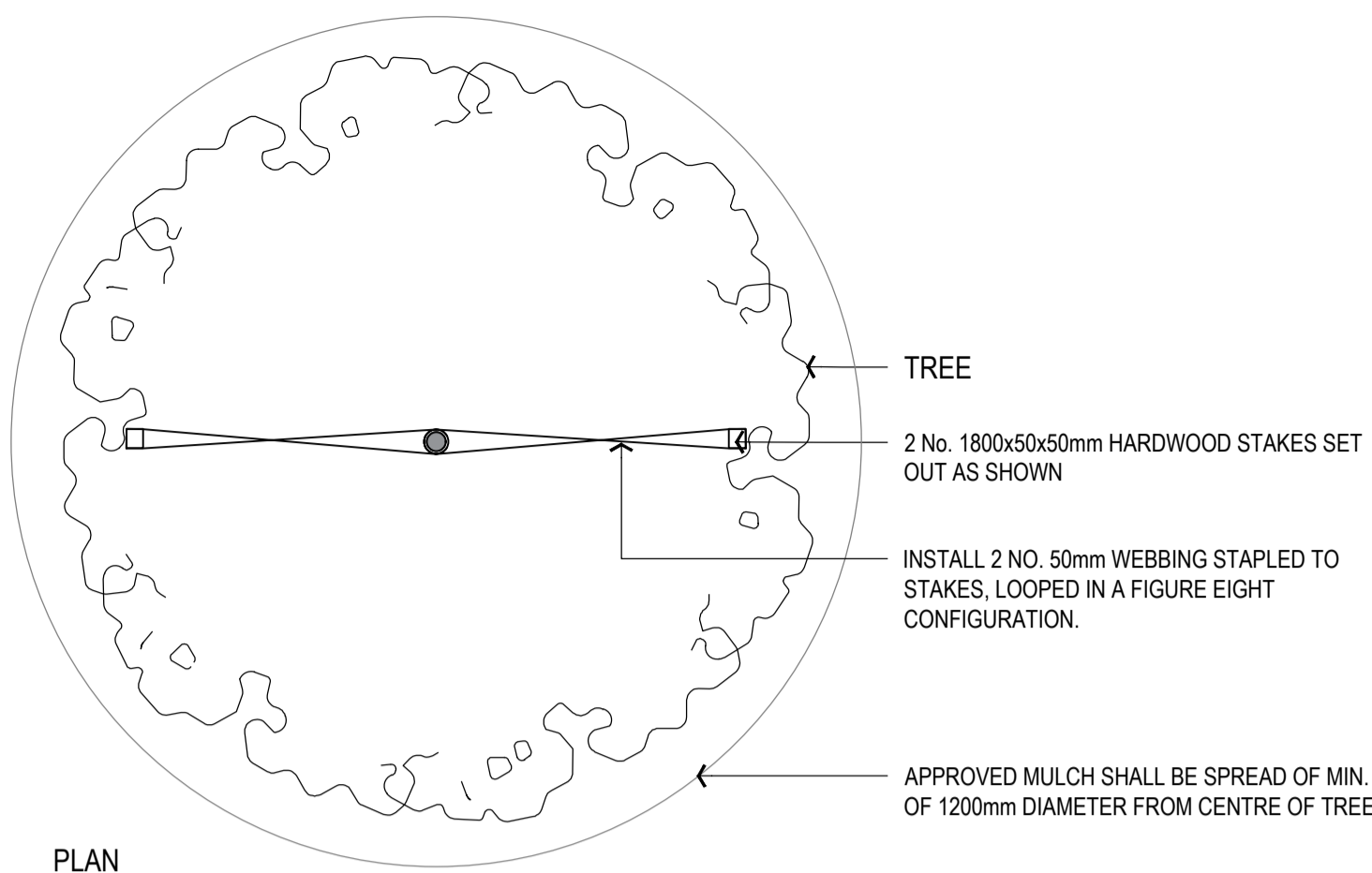

PLAN

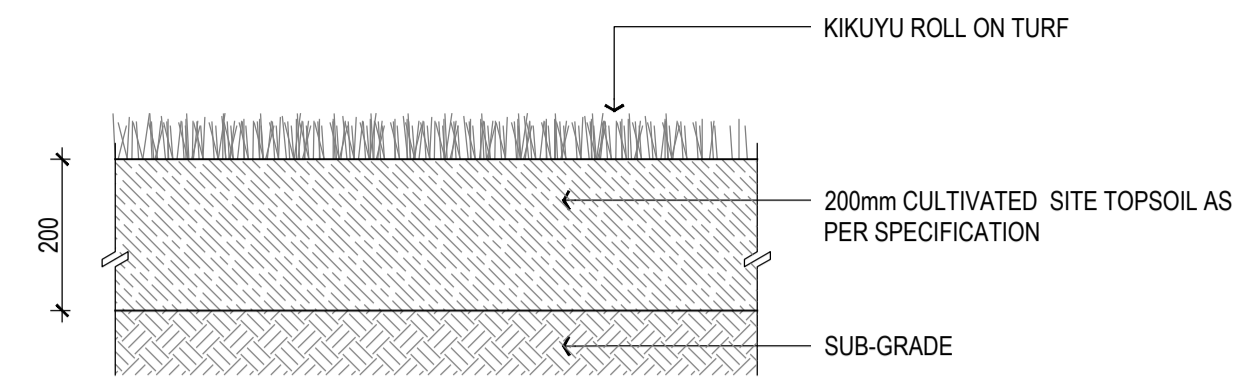

2 ROLL-ON TURF AREAS SECTION SCALE 1:10

**SEED MIX**  
 50% Themada trianda  
 35% Rytidosperra caespitosum  
 15% Rytidosperra racemosum  
**ALL SEED TO BE NATIVE PROVENANCE**

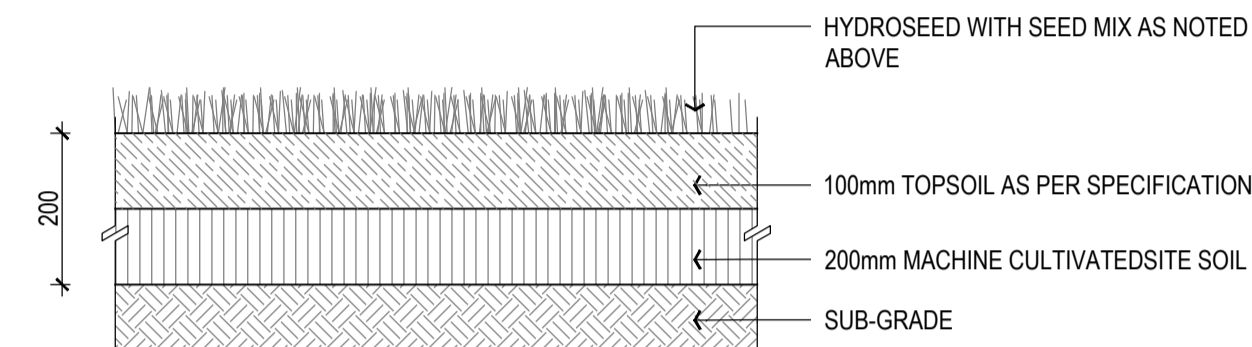

**NOTES**

- Existing pasture grass and/or weeds are to be sprayed with herbicide.
- No machinery to be used within the drip line of existing trees.
- Topsoil to be raked to a fine lith, removal of all surface rocks, large lumps of clay, weeds and rubbish prior to application of seed to all areas as shown.
- New grassed areas to be protected from trespass and traffic with star pickets and barrier rope until grass is established.

3 HYDROSEED TURF AREAS SECTION SCALE 1:10

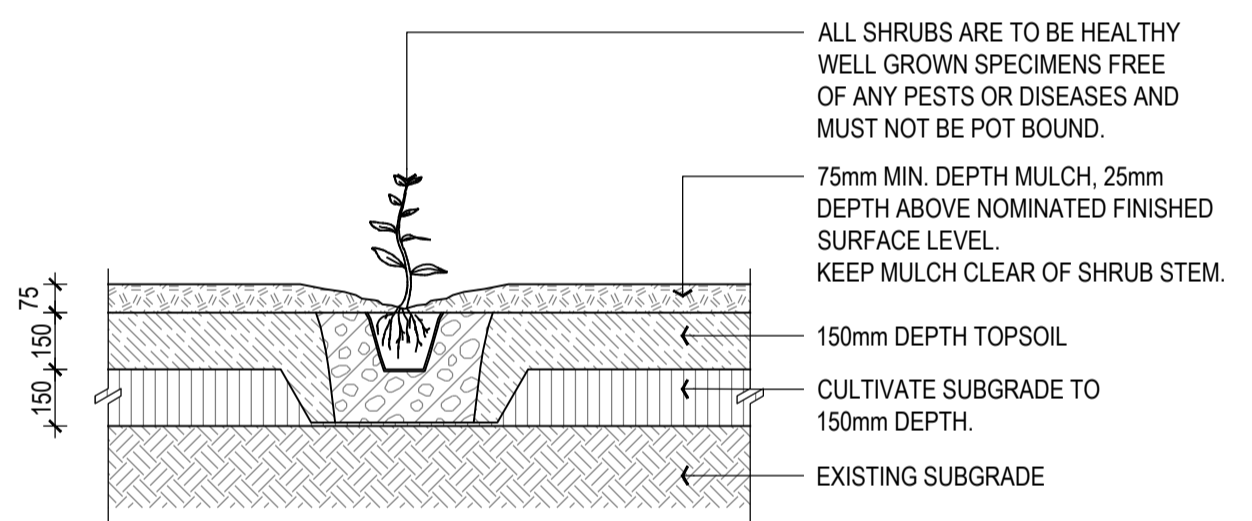

4 140mm - 200mm POT PLANTING SECTION SCALE 1:20

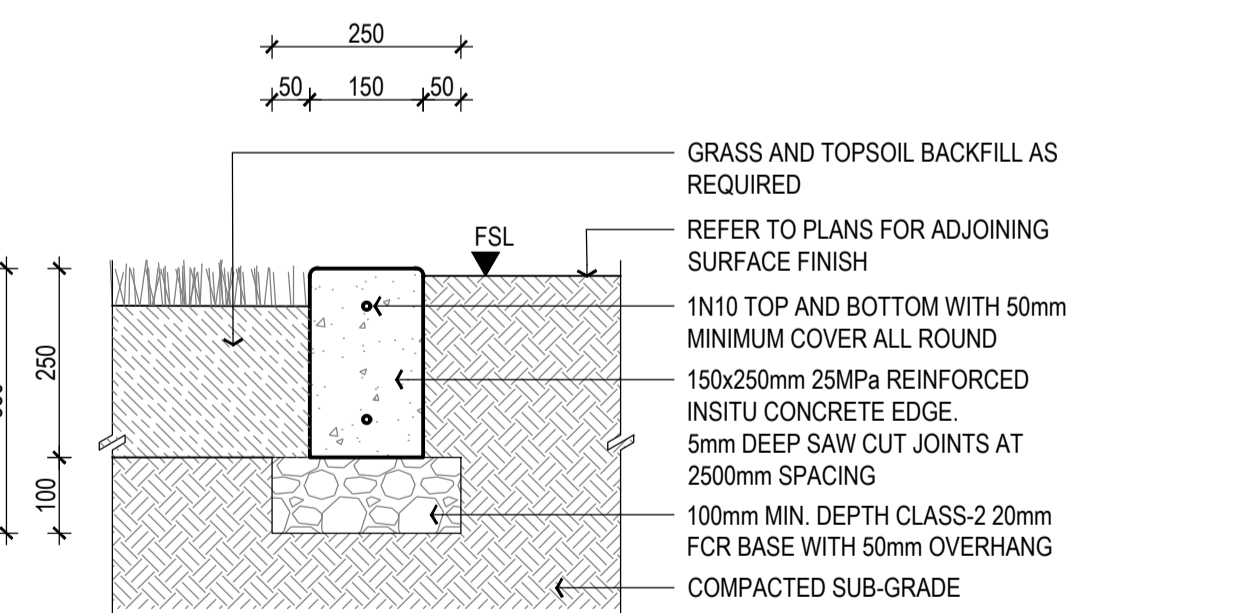

5 (MK) MOWING KERB SECTION SCALE 1:10

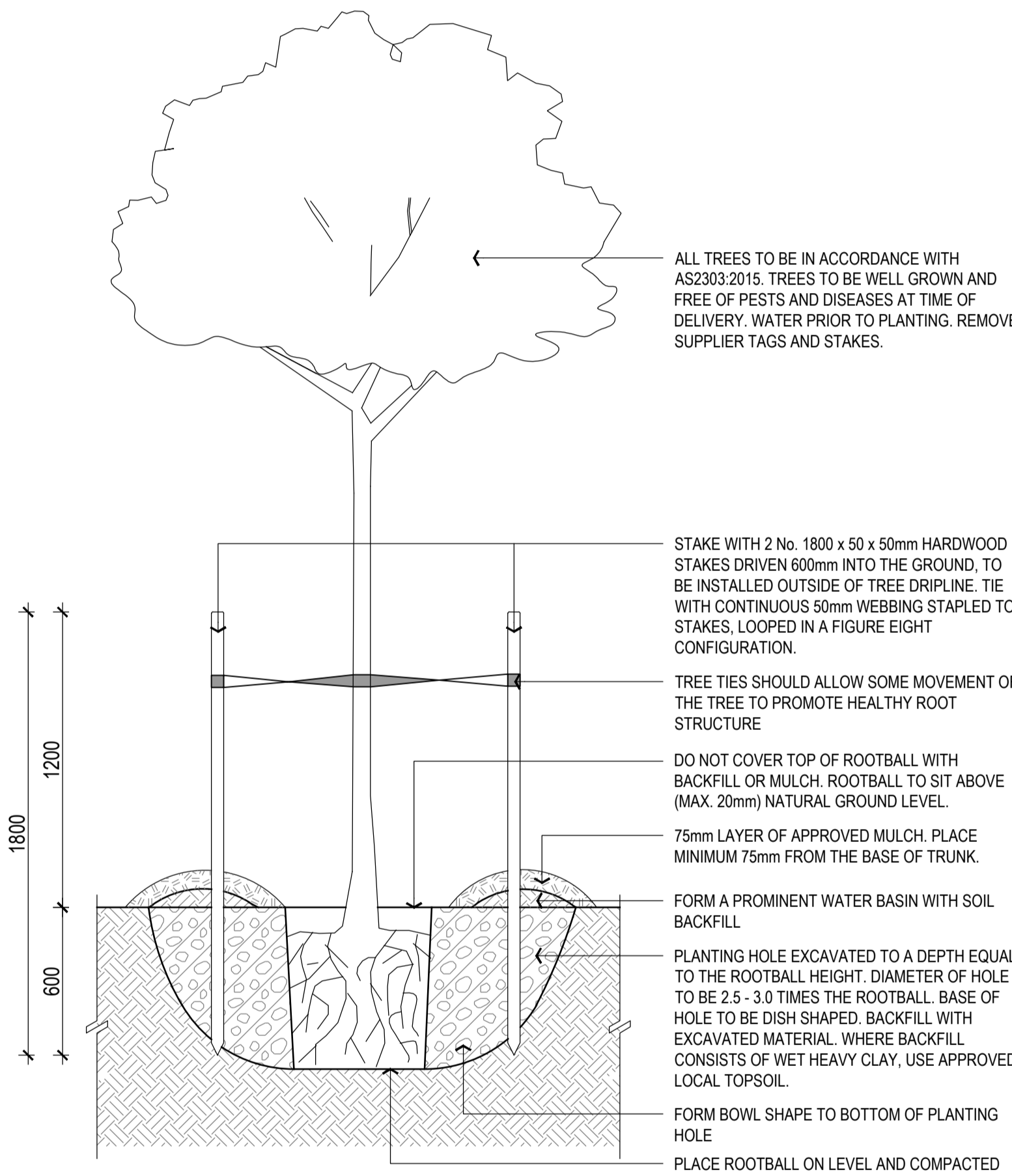

SECTION

**NOTES**

- IT IS THE RESPONSIBILITY OF THE CONTRACTOR TO CONFIRM THE LOCATION OF ALL UNDERGROUND SERVICES PRIOR TO COMMENCEMENT OF ANY EXCAVATION WORKS, TREE PLANTING, SPECIFICATIONS, STREET TREE OFFSETS / CLEARANCE, HOLD POINTS, SPECIES SUBSTITUTION, TREE STAKING AND TREE MAINTENANCE TO BE UNDERTAKEN IN ACCORDANCE WITH CITY OF WHITTLESEA MINIMUM LANDSCAPE MAINTENANCE SPECIFICATION OF SERVICES AND WORKS MAY 2010.
- TREE WATERING (1): IMMEDIATELY AFTER PLANTING, TREE SHALL BE WATERED THOROUGHLY REGARDLESS OF WEATHER CONDITIONS, QUANTITY OF WATER WILL BE ADEQUATE TO SATURATE THE ROOT BALL TO ITS CORE
- TREE WATERING (2): POST PLANTING, PROVIDE A MINIMUM OF 15 LITRES OF WATER (FOR TREE IN 45 LITRE POT) TO THE NEWLY PLANTED TREE PER 7 DAYS, WATER AT A SLOW RATE SO AS NOT TO DISPLACE MULCH. FOR TREES IN POT SIZE LARGER THAN 45 LITRES, PROVIDE QUANTITY OF WATER ONE THIRD OF THAT POT SIZE.

1 45 LITRE ADVANCED TREE PLANTING PLAN, SECTION SCALE 1:20

**PLANNING AND ENVIRONMENT ACT**  
**CITY OF WHITTLESEA**  
**PLANNING SCHEME**  
 Plan referred to in Permit to use and/or develop land.  
 Application: 717639  
 Condition No: 14.2  
 Sheet 8 of 9  
 Date Permit issued: 06/03/2019  
 Date: 22/08/2024  
 Town Planner

**STANDARD NOTES**

- SET OUT & DIMENSIONS.** THE CONTRACTOR SHALL SET OUT ALL PATHS, WALLS, PAVED SURFACES AND ELEMENTS EITHER ON OR OFF SITE PRIOR TO CONSTRUCTION AND SHALL DETAIN THE SUPERINTENDENT'S SET OUT APPROVAL PRIOR TO WORKS COMMENCING. WRITTEN DIMENSIONS SHALL TAKE PRECEDENCE OVER SCALE. CHECK ALL DRAWING SCALES IN CONJUNCTION WITH DRAWING SIZE.
- SERVICES & SITE ASSETS.** THE CONTRACTOR SHALL INVESTIGATE THE NATURE AND LOCATION OF ALL EXISTING SERVICES AND RETAINED SITE ASSETS AFFECTED BY THEIR WORKS. FAILURE TO TAKE DUE CARE SHALL NOT LIMIT THE CONTRACTOR'S LIABILITIES.
- REFERENCE.** THE CONTRACTOR SHALL REFER TO ALL CONTRACT DOCUMENTS, THE SPECIFICATION AND DRAWINGS PRIOR TO AND DURING THE WORKS.
- DISCREPANCIES.** NOTIFY SUPERINTENDENT OF ANY SUSPECTED DISCREPANCIES OR ERRORS PRIOR TO THE ORDERING OF AFFECTED MATERIALS AND OR CONSTRUCTION OF AFFECTED WORKS.
- RELEVANT STANDARDS.** THE CONTRACTOR SHALL UNDERTAKE ALL PRICING AND WORKS IN ACCORDANCE WITH CURRENT INDUSTRY BEST PRACTICE AND ALL RELEVANT AUSTRALIAN STANDARDS.
- SERVICE LOCATOR.** THE CONTRACTOR SHALL UNDERTAKE A DIAL BEFORE YOU DIG PROCESS PRIOR TO COMMENCING WORKS ON SITE. THE CONTRACTOR SHALL ENGAGE A SERVICE LOCATOR TO MAP THE SPECIFIC LOCATIONS AND DEPTHS OF ALL SERVICES AND ADVISE ALL RELEVANT STAFF AND SUBCONTRACTORS IN WRITING PRIOR TO COMMENCING WORKS ON SITE.

REV	DATE	BY	ISSUE OR AMENDMENT
H	01/08/2024	SR	ISSUED FOR COUNCIL APPROVAL
G	24/05/2024	SR	ISSUED FOR COUNCIL APPROVAL
F	10/05/2024	SR	ISSUED FOR COUNCIL APPROVAL
E	05/04/2023	SR	ISSUED FOR COUNCIL APPROVAL
D	28/08/2023	SR	ISSUED FOR COUNCIL REVIEW
C	16/03/2023	SR	ISSUED FOR ELECTRICAL COORDINATION
B	16/02/2023	SR	ISSUED FOR CLIENT COORDINATION
A	24/01/2023	SR	ISSUED FOR CLIENT COORDINATION

THIS IS AN UNCONTROLLED DOCUMENT ISSUED FOR INFORMATION ONLY UNLESS SIGNED BELOW AT EACH RELEVANT STAGE.

**INTERNAL DESIGN REVIEW**  
 THIS DESIGN IS NOT AUTHORISED FOR TENDER WITHOUT BEING INTERNALLY REVIEWED AND SIGNED HERE. EMERGE DIRECTOR DATE

**INTERNAL PRE-TENDER REVIEW**  
 THIS DRAWING IS NOT AUTHORISED FOR TENDER WITHOUT BEING INTERNALLY REVIEWED AND SIGNED HERE. EMERGE DIRECTOR DATE

**AUTHORISED FOR CONSTRUCTION**  
 THIS DRAWING IS NOT AUTHORISED FOR CONSTRUCTION UNLESS IT IS MARKED 'REV 1' OR HIGHER AND IS SIGNED HERE. EMERGE DIRECTOR DATE

**emerge ASSOCIATES**  
 Integrated Science & Design  
 PERTH (08) 9380 4988 • MARGARET RIVER (08) 9758 8159

PROJECT  
 RATHDOWNE ESTATE  
 450 CRAIGIEBURN ROAD, WOLLERT, VICTORIA  
 STAGE OR PHASE  
 STAGE 31

DRAWING TITLE  
 SOFTWORKS DETAILS

CLIENT  
 VILLALWOOD

DESIGNED BY SR PRELIM DESIGN REVIEWED BY SLC  
 DRAWN BY SR PRELIM DWG REVIEWED BY SLC  
 DATE INITIALLY DRAWN 20/01/2023  
 SCALE AS SHOWN  
 DRAWING NUMBER RAT-S31-SS-970 REV H

**PRELIMINARY**  
 NOT FOR CONSTRUCTION  
 INFORMATION ONLY



**STREET VERGE NOTES**

**THE CITY OF WHITTLESEA COUNCIL  
LANDSCAPE GUIDELINES**

THE FOLLOWING GUIDELINES HAVE BEEN EXTRACTED FROM CITY OF WHITTLESEA COUNCIL LANDSCAPE GUIDELINES, A GUIDE TO GROWTH AREA - STREET TREE PLANTING, DEC 2015 AS REFERENCE.

**1. TREE SPECIFICATION**

MINIMUM OFFSET:	
a. DRIVEWAYS	2 METRES
b. STREET LIGHTS POLES	3 METRES
c. CONDUITS / SERVICES	1 METRE
d. DOMESTIC TAPPING POINTS	1 METRE
e. SIDE ENTRY PITS	1.5 METRES
f. FIRE PLUGS	1.5 METRE
g. FOOTPATHS	1.25+ METRES
h. BACK OF KERB	1.25+ METRES

**PLANNING AND ENVIRONMENT ACT  
CITY OF WHITTLESEA  
PLANNING SCHEME  
Plan referred to in Permit to use and/or develop land.  
Application: 717639  
Condition No: 14.2  
Sheet 9 of 9  
Date Permit issued: 06/03/2019**

*K. Smith*  
**Town Planner**      Date: 22/08/2024

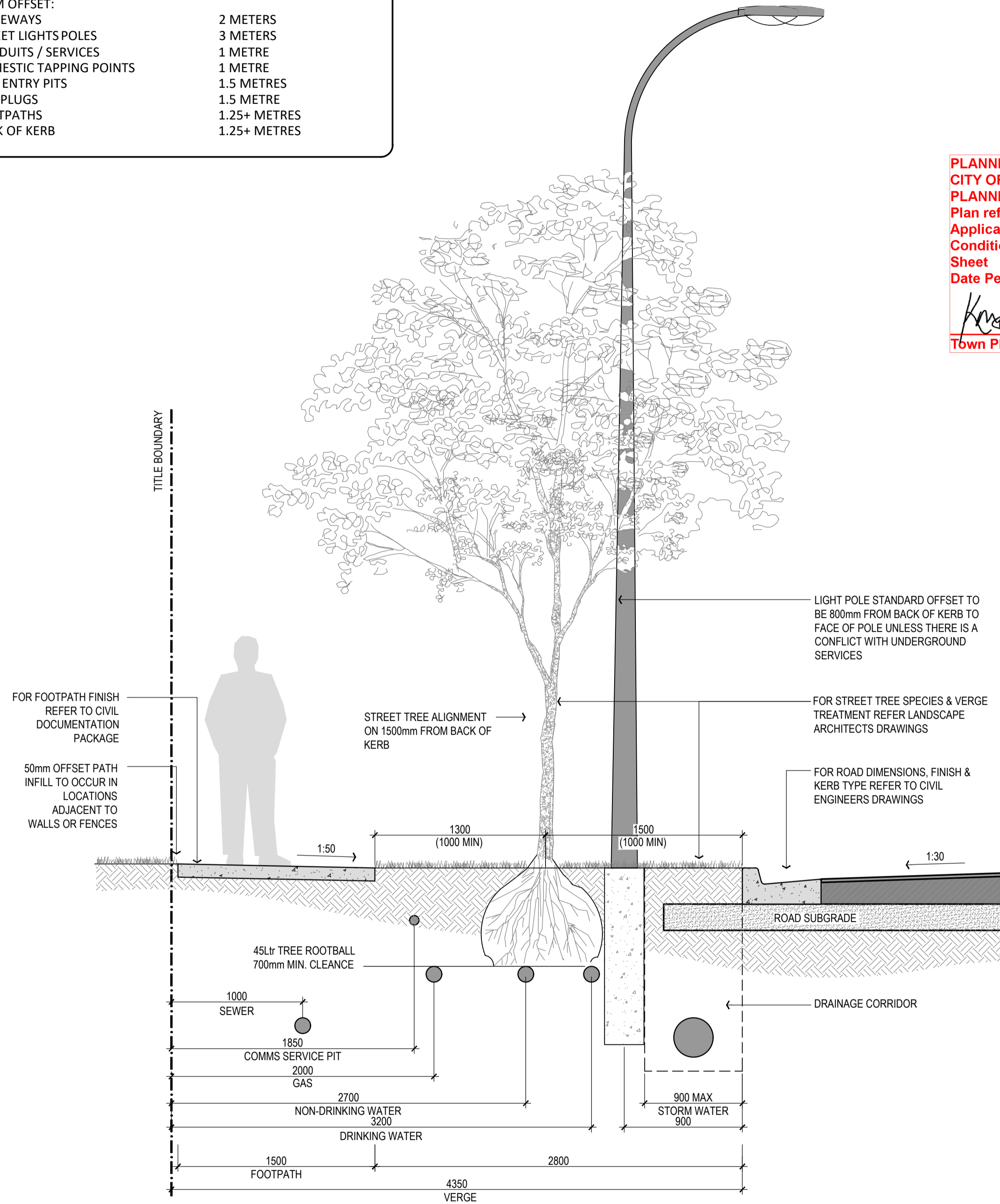

NOTE: THE CONTRACTOR SHALL UNDERTAKE ALL INVESTIGATIONS AS TO FINAL SERVICE LOCATIONS PRIOR TO WORKS. "DIAL BEFORE YOU DIG" PH: 1100.

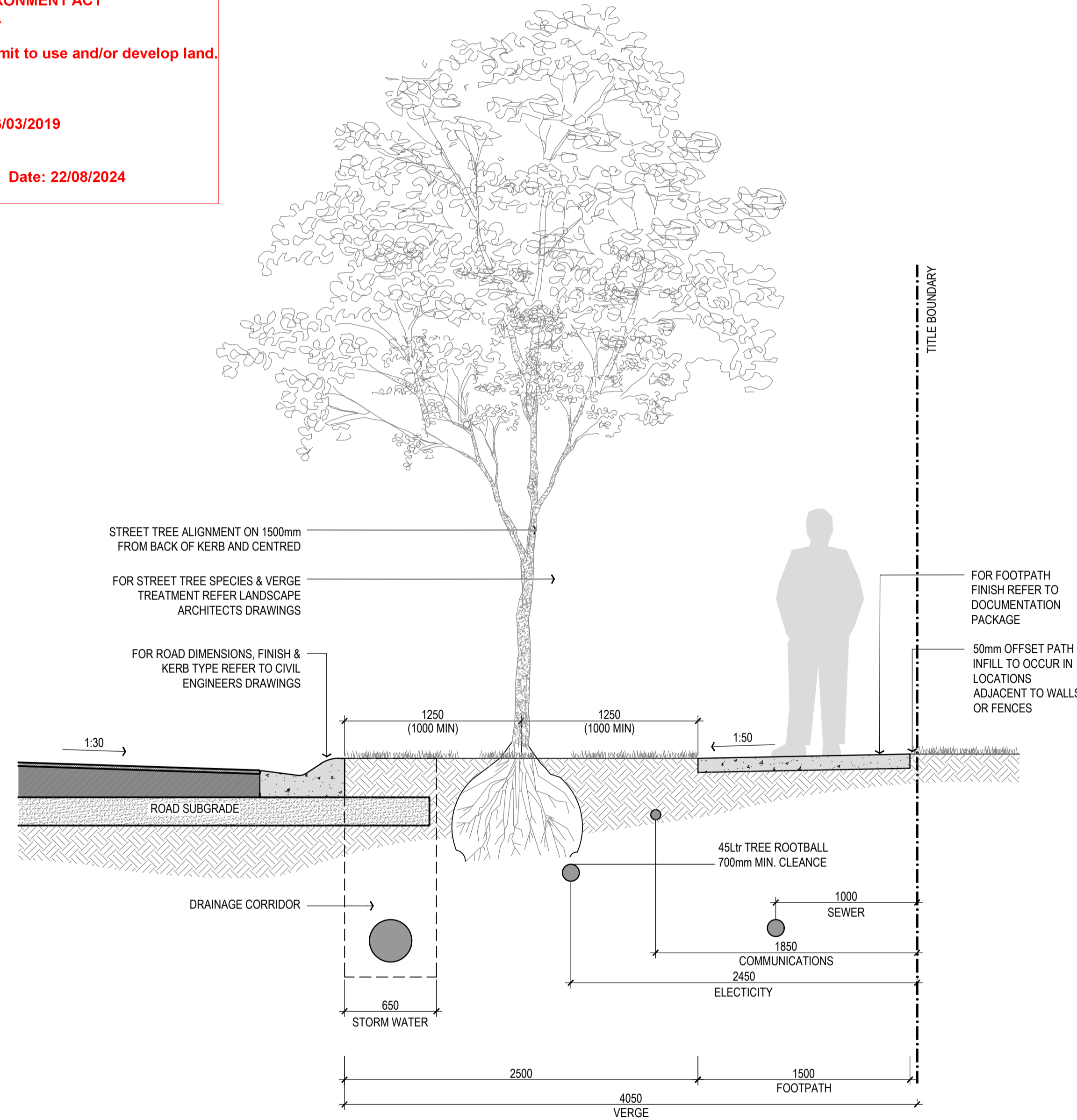

NOTE: THE CONTRACTOR SHALL UNDERTAKE ALL INVESTIGATIONS AS TO FINAL SERVICE LOCATIONS PRIOR TO WORKS. "DIAL BEFORE YOU DIG" PH: 1100.

1  
971 16.00m ROAD RESERVE - VERGE ALIGNMENTS  
SECTION

SCALE 1:25

**STANDARD NOTES**

- SET OUT & DIMENSIONS.** THE CONTRACTOR SHALL SET OUT ALL PATHS, WALLS, FENCES, SURFACES AND ELEMENTS EITHER ON OR OFFSITE PRIOR TO CONSTRUCTION AND SHALL OBTAIN THE SUPERINTENDENT'S SET OUT APPROVAL PRIOR TO WORKS COMMENCING. WRITTEN DIMENSIONS SHALL TAKE PRECEDENCE OVER SCALE. CHECK ALL DRAWING SCALES IN CONJUNCTION WITH DRAWING SIZE.
- SERVICES & SITE ASSETS.** THE CONTRACTOR SHALL INVESTIGATE THE NATURE AND LOCATION OF ALL EXISTING SERVICES AND RETAINED SITE ASSETS AFFECTED BY THEIR WORKS. FAILURE TO TAKE DUE CARE SHALL NOT LIMIT THE CONTRACTOR'S LIABILITIES.
- REFERENCE.** THE CONTRACTOR SHALL REFER TO ALL CONTRACT DOCUMENTS, THE SPECIFICATION AND DRAWINGS PRIOR TO AND DURING THE WORKS.
- DISCREPANCIES.** NOTIFY SUPERINTENDENT OF ANY SUSPECTED DISCREPANCIES OR ERRORS PRIOR TO THE ORDERING OF AFFECTED MATERIALS AND/OR CONSTRUCTION OF AFFECTED WORKS.
- RELEVANT STANDARDS.** THE CONTRACTOR SHALL UNDERTAKE ALL PRICING AND WORKS IN ACCORDANCE WITH CURRENT INDUSTRY BEST PRACTICE AND ALL RELEVANT AUSTRALIAN STANDARDS.
- SERVICE LOCATOR.** THE CONTRACTOR SHALL UNDERTAKE A DIAL BEFORE YOU DIG PROCESS PRIOR TO COMMENCING WORKS ON SITE. THE CONTRACTOR SHALL ENGAGE A SERVICE LOCATOR TO MAP THE SPECIFIC LOCATIONS AND DEPTHS OF ALL SERVICES AND ADVISE ALL RELEVANT STAFF AND SUBCONTRACTORS IN WRITING PRIOR TO COMMENCING WORKS ON SITE.

H	01/08/2024	SR	ISSUED FOR COUNCIL APPROVAL
G	24/05/2024	SR	ISSUED FOR COUNCIL APPROVAL
F	10/05/2024	SR	ISSUED FOR COUNCIL APPROVAL
E	05/04/2023	SR	ISSUED FOR COUNCIL APPROVAL
D	28/08/2023	SR	ISSUED FOR COUNCIL REVIEW
C	16/03/2023	SR	ISSUED FOR ELECTRICAL COORDINATION
B	16/02/2023	SR	ISSUED FOR CLIENT COORDINATION
A	24/01/2023	SR	ISSUED FOR CLIENT COORDINATION

THIS IS AN UNCONTROLLED DOCUMENT ISSUED FOR INFORMATION ONLY UNLESS SIGNED BELOW AT EACH RELEVANT STAGE.

INTERNAL DESIGN REVIEW	EMERGE DIRECTOR	DATE
THIS DESIGN IS NOT AUTHORISED FOR TENDER WITHOUT BEING INTERNALLY REVIEWED AND SIGNED HERE		
INTERNAL PRETENDER REVIEW	EMERGE DIRECTOR	DATE
THIS DRAWING IS NOT AUTHORISED FOR TENDER WITHOUT BEING INTERNALLY REVIEWED AND SIGNED HERE		
AUTHORISED FOR CONSTRUCTION	EMERGE DIRECTOR	DATE
THIS DRAWING IS NOT AUTHORISED FOR CONSTRUCTION UNLESS IT IS MARKED REV 1 OR HIGHER AND IS SIGNED HERE		

**emerge ASSOCIATES**  
Integrated Science & Design  
PERTH (08) 9380 4988 • MARGARET RIVER (08) 9758 8159

PROJECT  
RATHDOWNE ESTATE  
450 CRAIGIEBURN ROAD, WOLLERT, VICTORIA  
STAGE OR PHASE  
STAGE 31

DRAWING TITLE  
STREET TREE SECTION

CLIENT  
VILLAWOOD

DESIGNED BY SR PRELIM DESIGN REVIEWED BY SLC  
DRAWN BY SR PRELIM DWG REVIEWED BY SLC  
DATE INITIALLY DRAWN 20/01/2023  
SCALE AS SHOWN  
DRAWING NUMBER RAT-S31-SS-971 REV H

**PRELIMINARY**  
NOT FOR CONSTRUCTION  
INFORMATION ONLY