

PLAN OF SUBDIVISION

Under Section 37 of the Subdivision Act 1988

LUV USE ONLY

EDITION

PLAN NUMBER

PS841640V

LOCATION OF LAND

COUNCIL NAME: WYNDHAM CITY COUNCIL

PARISH: TARNEIT

TOWNSHIP: -

SECTION: 8

CROWN ALLOTMENT: A1 (PART)

CROWN PORTION: -

TITLE REFERENCES: Vol.12239 Fol.715

LAST PLAN REFERENCE/S: PS822740Y (LOT S)

POSTAL ADDRESS: HERMOSA DRIVE
(At time of subdivision) TARNEIT, 3029

MGA94 Co-ordinates E 292 150
(of approx centre of N 5 808 460
land in plan) ZONE 55

VESTING OF ROADS AND/OR RESERVES

NOTATIONS

IDENTIFIER	COUNCIL/BODY/PERSON
ROAD R1	WYNDHAM CITY COUNCIL
RESERVE No.1	WYNDHAM CITY COUNCIL
RESERVE No.2	WYNDHAM CITY COUNCIL

LOTS ON THIS PLAN MAY BE AFFECTED BY ONE OR MORE OWNERS CORPORATIONS (SEE OWNERS CORPORATION SEARCH REPORT FOR DETAILS).

LOTS 1 TO 100 (BOTH INCLUSIVE) HAVE BEEN OMITTED FROM THIS PLAN.

EASEMENTS E-8 & E-9 HAVE BEEN OMITTED FROM THIS PLAN.

LOTS ON THIS PLAN MAY BE AFFECTED BY ONE OR MORE RESTRICTIONS. SEE SHEET 9 FOR FURTHER DETAILS.

CP1 DENOTES COMMON PROPERTY 1.

COMMON PROPERTY 1 IS NOT SHOWN TO SCALE ON THIS PLAN.

OTHER PURPOSES OF THE PLAN:

REMOVAL OF THAT PART OF DRAINAGE EASEMENT E-3 ON PS822740Y INsofar AS IT AFFECTS ODARA MEWS ON THIS PLAN.

GROUNDS FOR REMOVAL AND VARIATION:

BY AGREEMENT OF ALL INTERESTED PARTIES UPON REGISTRATION OF THIS PLAN PURSUANT TO SECTION 6 (1)(k)(iv) OF THE SUBDIVISION ACT 1988.

NOTATIONS

DEPTH LIMITATION 15.24m BELOW THE SURFACE.

STAGING THIS IS A STAGED SUBDIVISION.
PLANNING PERMIT No. WYP10107

SURVEY. THIS PLAN IS BASED ON SURVEY.

THIS SURVEY HAS BEEN CONNECTED TO PERMANENT MARKS No(s):
PM17 (WERRIBEE) AND PM18, PM134, PM217 & PM760 (TARNEIT)

PROCLAIMED SURVEY AREA:

ALAMORA 1
4.964ha

37 LOTS

EASEMENT INFORMATION

LEGEND A-Appurtenant Easement E-Encumbering Easement R-Encumbering Easement (Road)

Easement Reference	Purpose	Width (Metres)	Origin	Land Benefited/In Favour Of
E-1	SEWERAGE	SEE PLAN	PS820473G	CITY WEST WATER CORPORATION
E-2	DRAINAGE SEWERAGE	SEE PLAN SEE PLAN	PS822737M PS822737M	WYNDHAM CITY COUNCIL CITY WEST WATER CORPORATION
E-3	DRAINAGE SEWERAGE WATER SUPPLY (THROUGH UNDERGROUND PIPES)	SEE PLAN SEE PLAN SEE PLAN	PS822740Y PS822740Y PS822740Y	WYNDHAM CITY COUNCIL CITY WEST WATER CORPORATION CITY WEST WATER CORPORATION
SEE SHEET 2 FOR CONTINUATION				

2070S-01 VER F.DWG SB/BC



SURVEYOR REF: **2070s-01**

ORIGINAL SHEET
SIZE: A3

SHEET 1 OF 9

GABRIELLE MCCARTHY VERSION F

PLAN OF SUBDIVISION

Under Section 37 of the Subdivision Act 1988

PLAN NUMBER
PS841640V

Easement Reference	Purpose	Width (Metres)	Origin	Land Benefited/In Favour Of
E-4	SEWERAGE	SEE PLAN	PS822740Y	CITY WEST WATER CORPORATION
E-5	SEWERAGE	SEE PLAN	PS817174L	CITY WEST WATER CORPORATION
E-6	DRAINAGE	SEE PLAN	THIS PLAN	WYNDHAM CITY COUNCIL
E-7	SEWERAGE	SEE PLAN	THIS PLAN	CITY WEST WATER CORPORATION
E-10	DRAINAGE	SEE PLAN	THIS PLAN	WYNDHAM CITY COUNCIL
	SEWERAGE	SEE PLAN	THIS PLAN	CITY WEST WATER CORPORATION
	WATER SUPPLY (THROUGH UNDERGROUND PIPES)	SEE PLAN	THIS PLAN	CITY WEST WATER CORPORATION
	DISTRIBUTION AND/OR TRANSMISSION OF GAS	SEE PLAN	THIS PLAN (SECTION 146 GAS INDUSTRY ACT 2001)	AUSNET GAS SERVICES PTY LTD

2070S-01 VER F.DWG SB/BC



Melbourne Survey T 9869 0813

REF 2070s-01

GABRIELLE MCCARTHY VERSION F

ORIGINAL SHEET
SIZE: A3

SHEET 2

PLAN OF SUBDIVISION

Under Section 37 of the Subdivision Act 1988

PLAN NUMBER
PS841640V

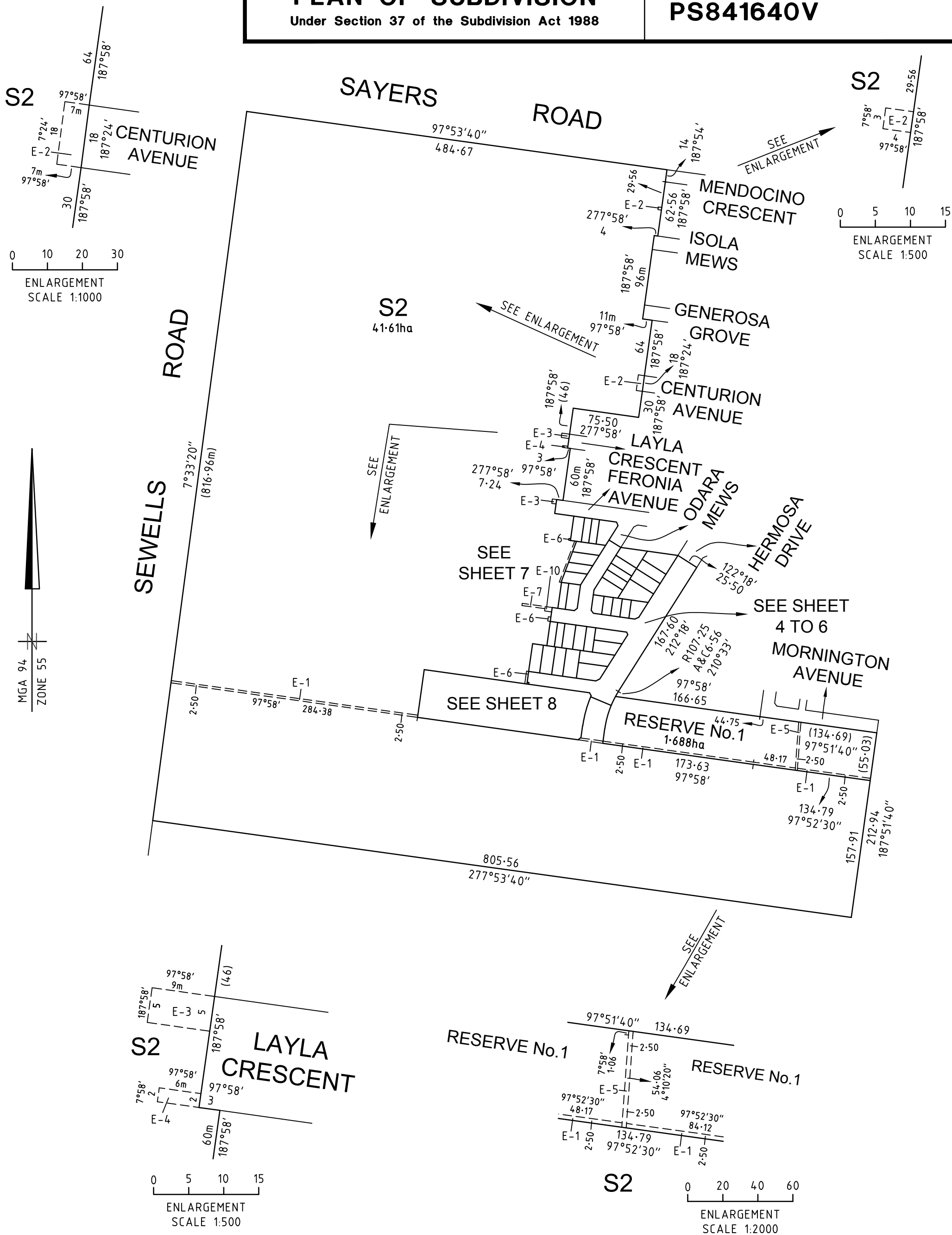

2070S-01 VER F.DWG SB/BC
SMEC
Melbourne Survey T 9869 0813 REF 2070s-01

SCALE 1:4000	40 0 40 80 120 160 LENGTHS ARE IN METRES
GABRIELLE MCCARTHY VERSION F	

ORIGINAL SHEET SIZE: A3	SHEET 3
----------------------------	---------

PLAN OF SUBDIVISION

Under Section 37 of the Subdivision Act 1988

PLAN NUMBER
PS841640V

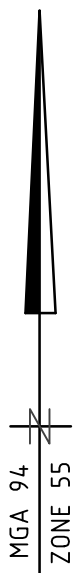

SEE SHEET 7

S2
SEE SHEET 3

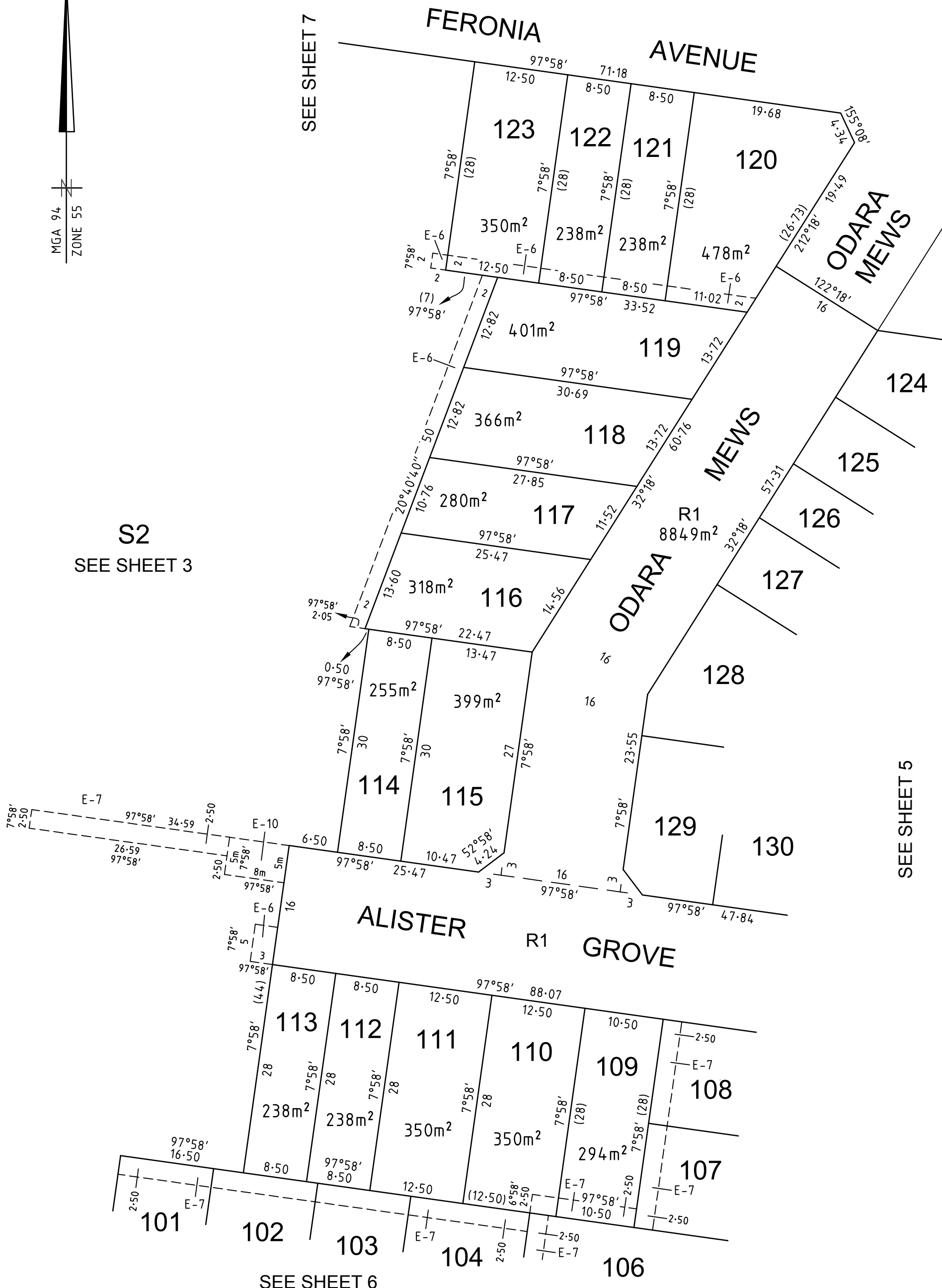

SEE SHEET 5

SEE SHEET 6



SMEC

Melbourne Survey T 9869 0813

2070S-01 VER F.DWG SB/BC

REF 2070s-01

SCALE
1:500

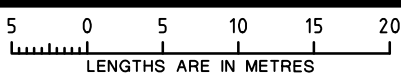

GABRIELLE MCCARTHY VERSION F

ORIGINAL SHEET
SIZE: A3

SHEET 4

PLAN OF SUBDIVISION

Under Section 37 of the Subdivision Act 1988

PLAN NUMBER

PS841640V

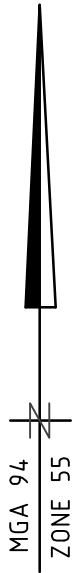

SEE SHEET 4

SEE SHEET 3

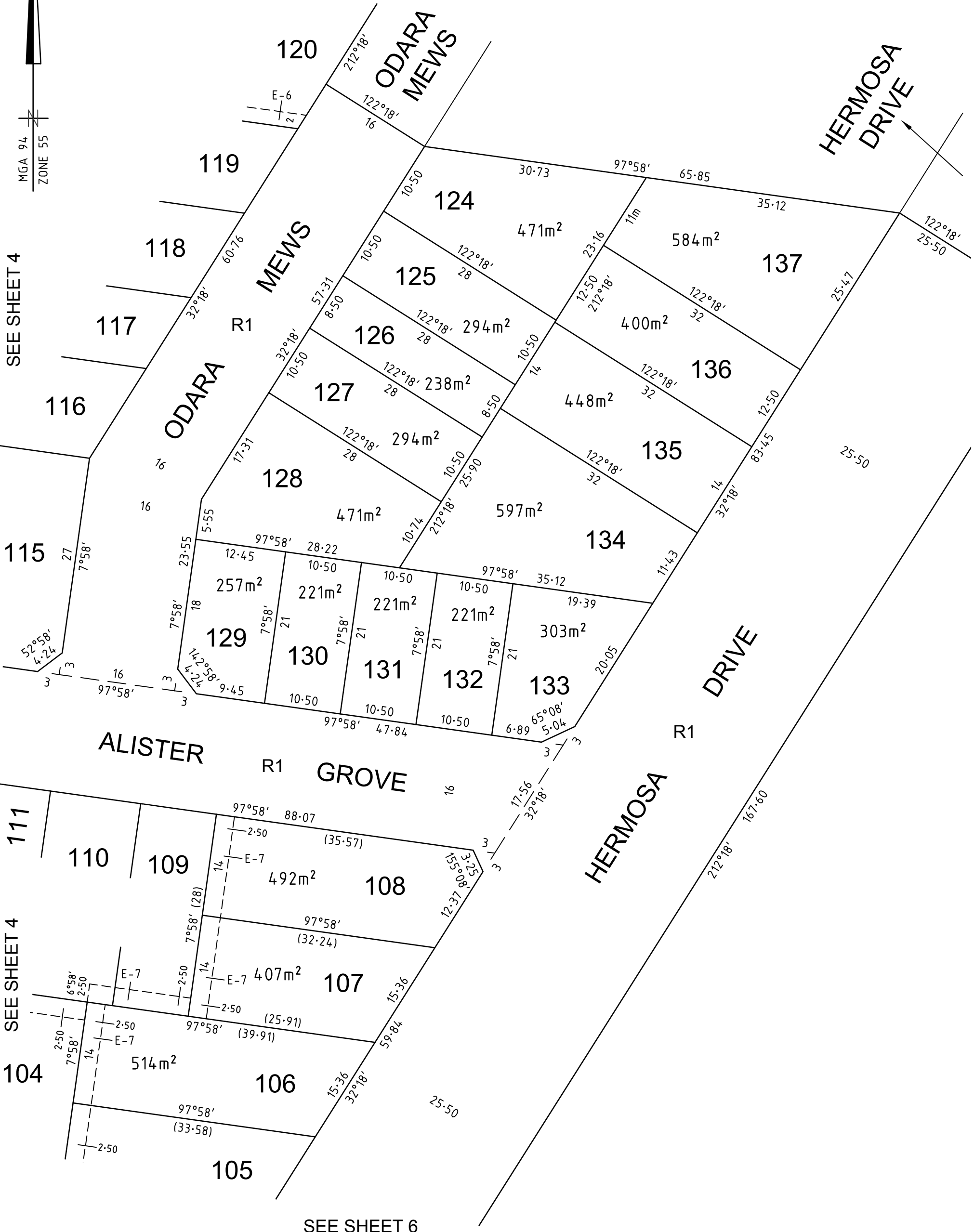

SEE SHEET 4

SEE SHEET 6



SMEC

Melbourne Survey T 9869 0813

REF 2070s-01

2070S-01 VER F.DWG SB/BC

SCALE
1:500

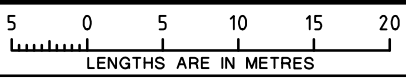

ORIGINAL SHEET
SIZE: A3

SHEET 5

GABRIELLE MCCARTHY VERSION F

PLAN OF SUBDIVISION

Under Section 37 of the Subdivision Act 1988

PLAN NUMBER
PS841640V

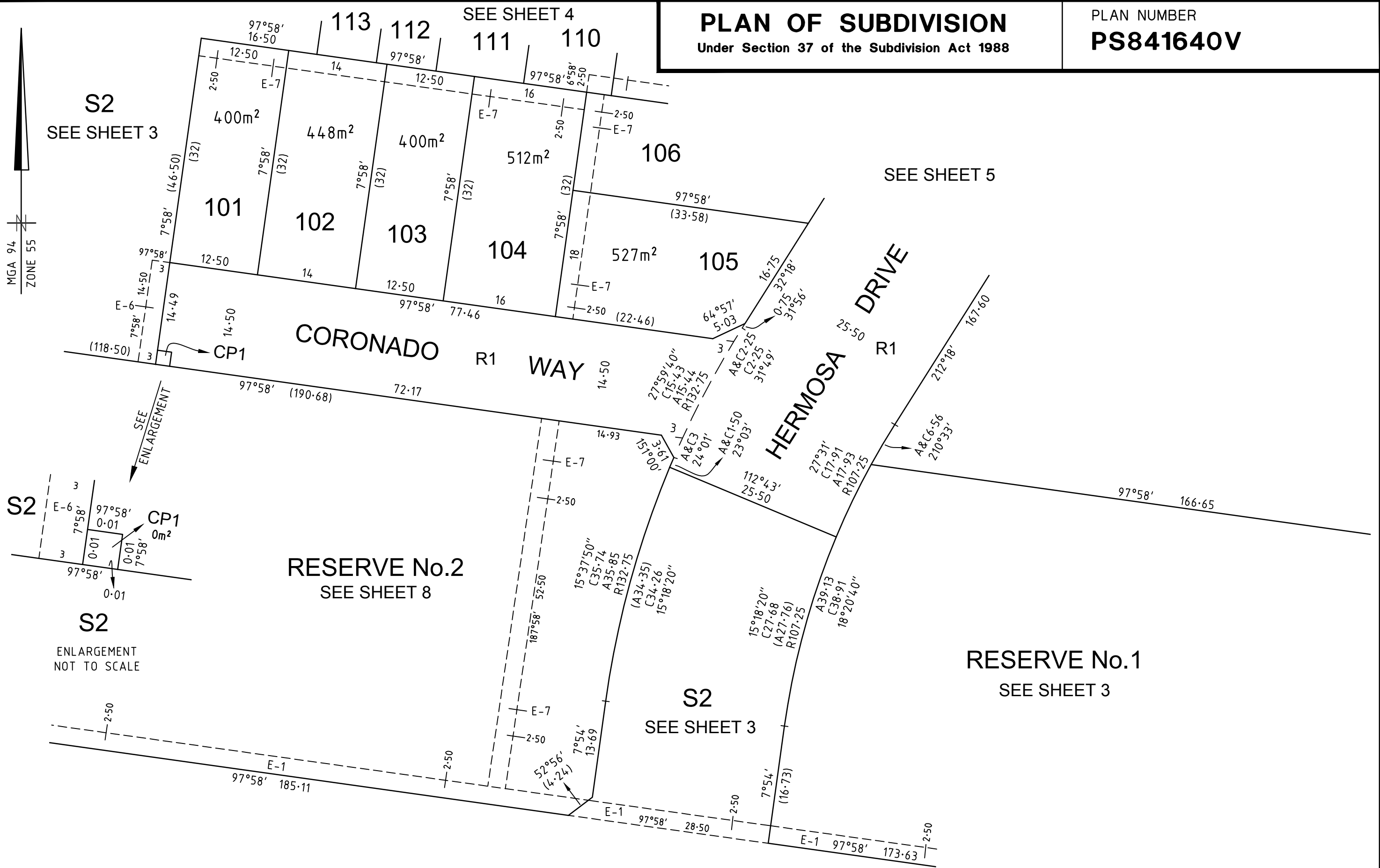

S2
SEE SHEET 3

SEE SHEET 5

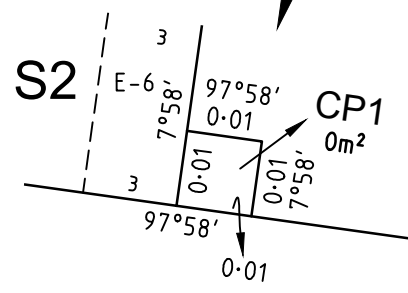

RESERVE No.2
SEE SHEET 8

RESERVE No.1
SEE SHEET 3

S2
SEE SHEET 3

2070S-01 VER F.DWG SB/BC
SMEC
Melbourne Survey T 9869 0813 REF 2070s-01

SCALE
1:500

LENGTHS ARE IN METRES

ORIGINAL SHEET
SIZE A3

SHEET 6

GABRIELLE MCCARTHY VERSION F

PLAN OF SUBDIVISION

Under Section 37 of the Subdivision Act 1988

PLAN NUMBER

PS841640V

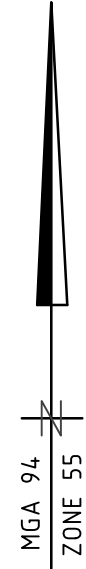

S2
SEE SHEET 3

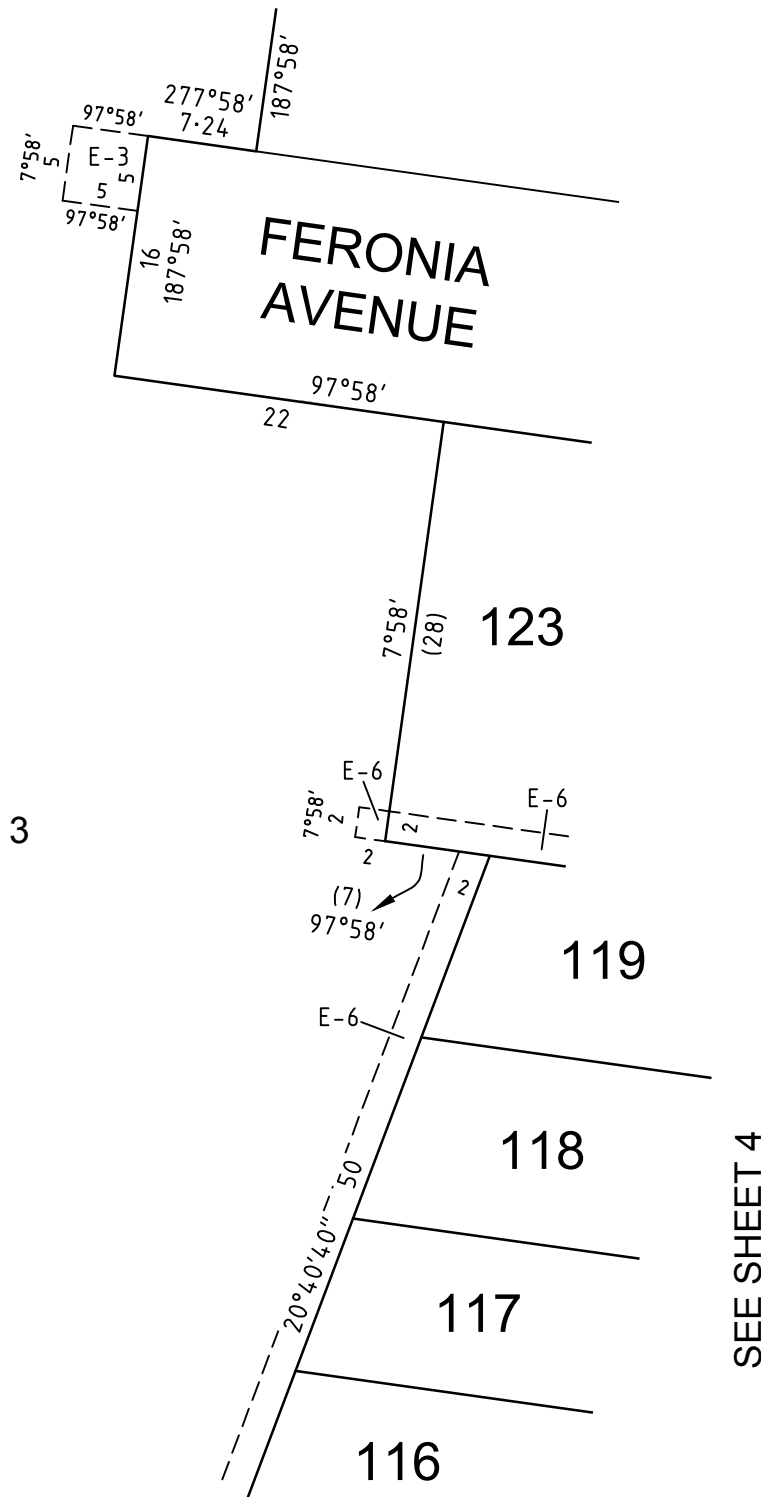

SEE SHEET 4

SCALE
1:500

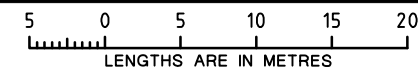

ORIGINAL SHEET
SIZE A3

SHEET 7

GABRIELLE MCCARTHY VERSION F

PLAN OF SUBDIVISION

Under Section 37 of the Subdivision Act 1988

PLAN NUMBER

PS841640V

MGA 94
ZONE 55

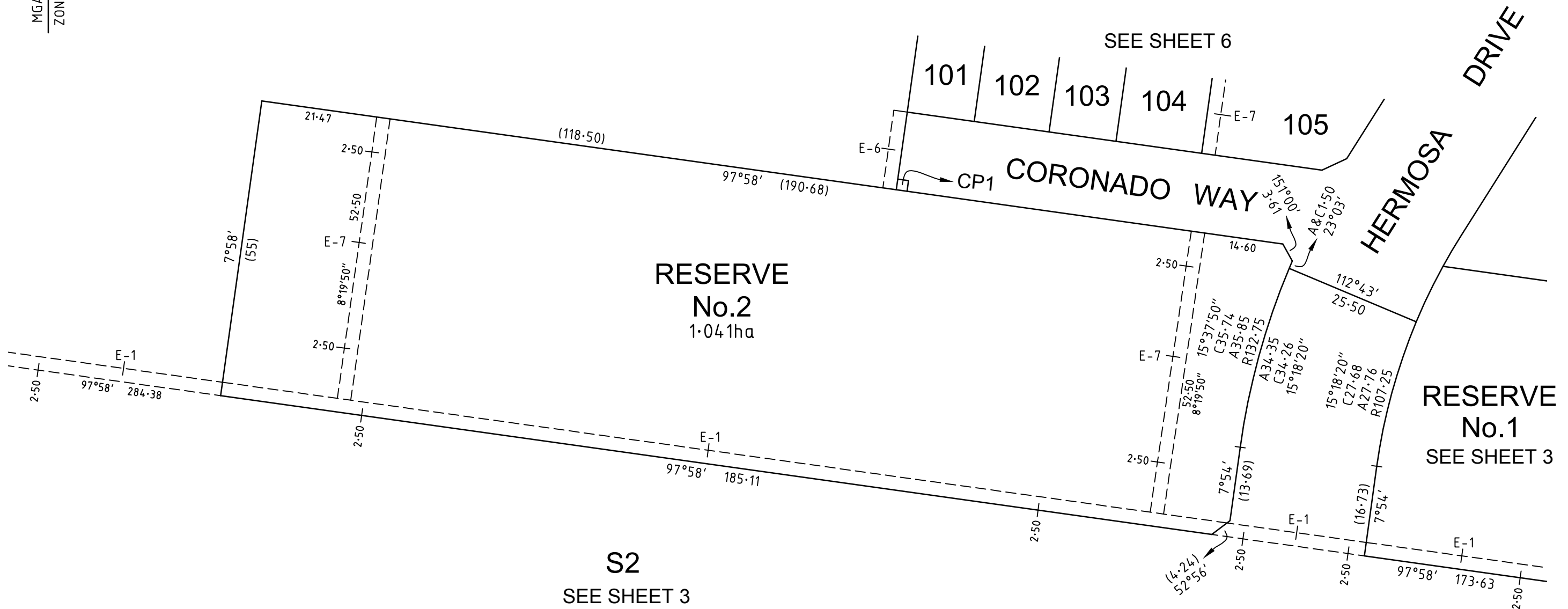

S2
SEE SHEET 3

RESERVE
No.1
SEE SHEET 3

2070S-01 VER F.DWG SB/BC



SMEC

Melbourne Survey T 9869 0813 REF 2070s-01

SCALE
1:750

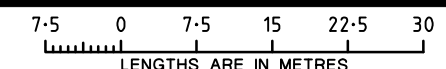

7.5 0 7.5 15 22.5 30
LENGTHS ARE IN METRES

ORIGINAL SHEET
SIZE A3

SHEET 8

GABRIELLE MCCARTHY VERSION F

PLAN OF SUBDIVISION

Under Section 37 of the Subdivision Act 1988

PLAN NUMBER

PS841640V

CREATION OF RESTRICTION A

The following Restriction is to be created upon registration of Plan of Subdivision PS841640V by way of a restrictive covenant and as a restriction as defined in the Subdivision Act 1988.

Table of Land Burdened and Land Benefited:

BURDENED LOT No.	BENEFITING LOTS
101	102
102	101, 103, 112, 113
103	102, 104, 111, 112
104	103, 105, 106, 110, 111
105	104, 106
106	104, 105, 107, 109, 110
107	106, 108, 109
108	107, 109
109	106, 107, 108, 110
110	104, 106, 109, 111
111	103, 104, 110, 112
112	102, 103, 111, 113
113	102, 112
114	115, 116
115	114, 116
116	114, 115, 117
117	116, 118
118	117, 119
119	118, 120, 121, 122, 123

BURDENED LOT No.	BENEFITING LOTS
120	119, 121
121	119, 120, 122
122	119, 121, 123
123	119, 122
124	125, 136, 137
125	124, 126, 135, 136
126	125, 127, 134, 135
127	126, 128, 134
128	127, 129, 130, 131, 134
129	128, 130
130	128, 129, 131
131	128, 130, 132, 134
132	131, 133, 134
133	132, 134
134	126, 127, 128, 131, 132, 133, 135
135	125, 126, 134, 136
136	124, 125, 135, 137
137	124, 136

DESCRIPTION OF RESTRICTION

The registered proprietor or proprietors for the time being of any burdened lot on the Plan of Subdivision must not without the consent of the Responsible Authority build or allow to be built on the lot:

Memorandum of Common Provisions (MCP)

1. Any building other than a building which has been constructed and sited in accordance with the Memorandum of Common Provisions registered in Dealing No. AA and which Memorandum of Common Provisions is incorporated in this plan.

Small Lot Housing Code

2. Any building in the case of lots less than 300 square metres unless in accordance with the Small Lot Housing Code or unless a specific Planning Permit for the building has been obtained from Wyndham City Council.

The restrictions in paragraphs 1 and 2 shall cease to burden any lot on the Plan of Subdivision with affect from 1st January 2031.